

RoHS Compliant Product

A suffix of "-C" specifies halogen & lead-free



TO-220

FEATURES

- * Low forward voltage drop
- * High current capability
- * High reliability
- * High surge current capability
- * Epitaxial construction

MECHANICAL DATA

- * Case: Molded plastic
- * Epoxy: UL 94V-0 rate flame retardant
- * Lead: Lead solderable per MIL-STD-202, method 208 guaranteed
- * Polarity: As Marked
- * Mounting position: Any
- * Weight: 2.24 grams

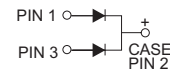
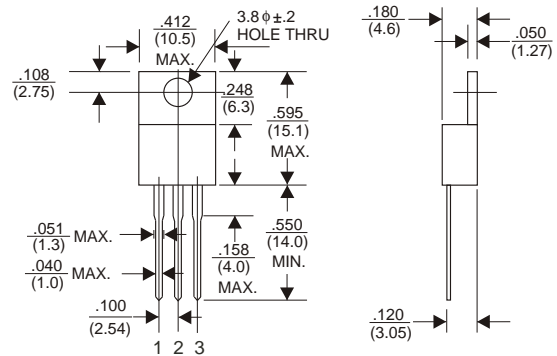

Dimensions in millimeters

MAXIMUM RATINGS AND ELECTRICAL CHARACTERISTICS

Rating 25°C ambient temperature unless otherwise specified.
Single phase half wave, 60Hz, resistive or inductive load.
For capacitive load, derate current by 20%.

TYPE NUMBER	SR1045	UNITS
Maximum Recurrent Peak Reverse Voltage	45	V
Working Peak Reverse Voltage	45	V
Maximum DC Blocking Voltage	45	V
Maximum Average Forward Rectified Current See Fig. 1	10	A
Peak Forward Surge Current, 8.3 ms single half sine-wave superimposed on rated load (JEDEC method)	150	A
Maximum Instantaneous Forward Voltage at 5.0A	0.55	V
Maximum DC Reverse Current Ta=25°C	0.5	mA
at Rated DC Blocking Voltage Ta=100°C	45	mA
Typical Junction Capacitance (Note1)	700	pF
Typical Thermal Resistance RθJC (Note 2)	3.0	°C/W
Operating Temperature Range Tj	-50 ~ +150	°C
Storage Temperature Range Tstg	-65 ~ +175	°C

NOTES:

1. Measured at 1MHz and applied reverse voltage of 4.0V D.C.
2. Thermal Resistance Junction to Case.

FIG.1-TYPICAL FORWARD CURRENT DERATING CURVE

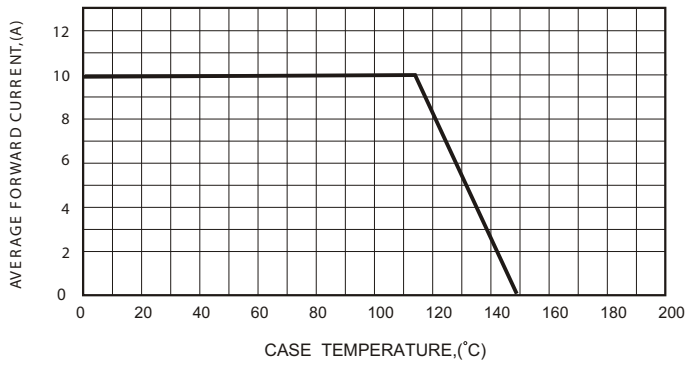

FIG.3-MAXIMUM NON-REPETITIVE FORWARD SURGE CURRENT

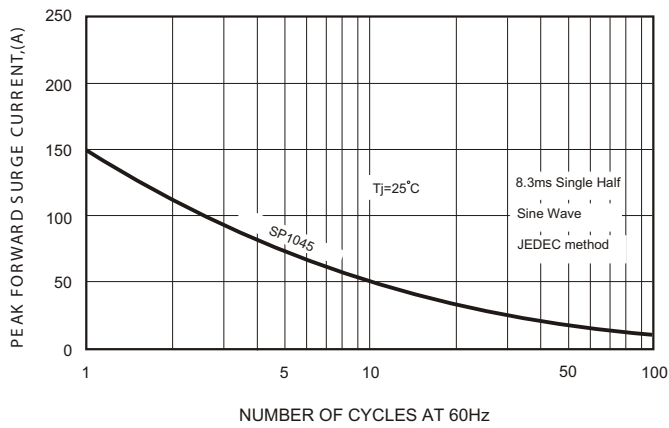

FIG.4-TYPICAL JUNCTION CAPACITANCE

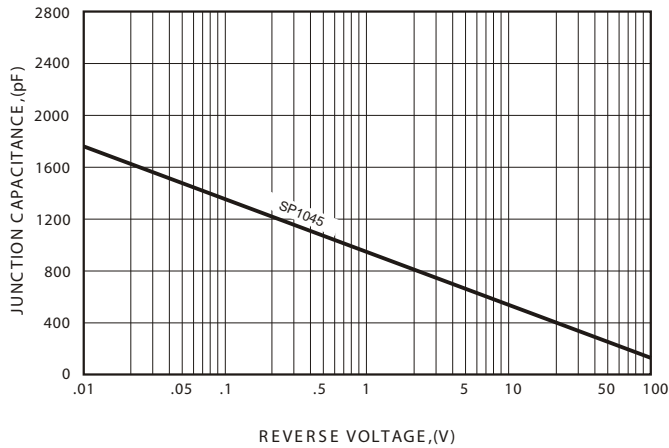

FIG.2-TYPICAL FORWARD CHARACTERISTICS

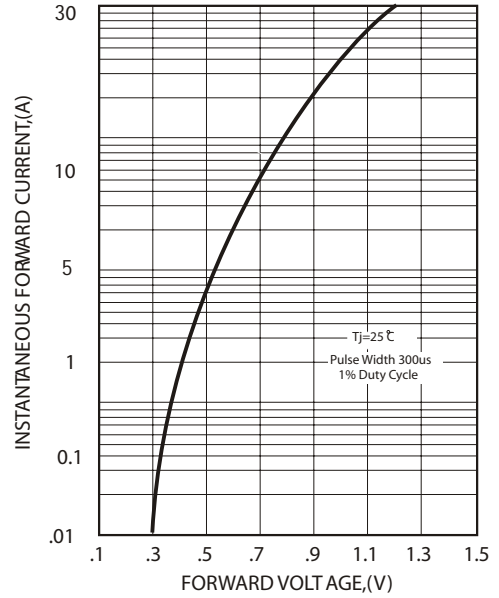

FIG.5 - TYPICAL REVERSE CHARACTERISTICS

