

DESCRIPTION

The FCI Model SPB-24 projected beam smoke detector is a line type of device designed to detect black, gray or white smoke over large, elongated areas. The system consists of an emitter and receiver. The emitter projects a near infrared pulsed beam to a receiver which may be located from 10 up to 100 meters (32.8 to 328 feet) from the emitter. Spacing between units can be as much as 45 feet on centers.

The length of protected path and ability to distinguish between blockage and smoke from fires make the SPB well suited for use in atriums, gymnasiums, theaters, museums, factories, tunnels, churches, cathedrals, anechoic chambers and high air velocity areas.

The detector has three field adjustable sensitivity settings for obscurations of 25%, 50% and 70%. These settings are dependent upon the monitoring distance and ceiling height. Should the smoke from a fire cause a decrease in the signal strength of a magnitude that exceeds the programmed obscuration setting, an alarm signal is generated. An interruption of 90% of the beam within a short period of time will create a trouble condition. Thus the unit can readily distinguish between a high smoke level and a sudden blockage or emitter failure.

Explosive atmospheres may also be protected by locating the transmitter and receiver heads facing each other from behind windows outside the explosive areas. The beam can be projected up to 30 meters (100 feet) in such applications.

Outputs from the receiver are Form "A" alarm contacts and Form "B" trouble contacts. This detector may be used with any UL listed 24 VDC control panel having the proper current capacity.

The receiver contains a microprocessor which automatically makes periodic adjustments to the system to compensate for normal ambient changes that cause contamination of the lenses and for aging components. Since such a change with time appears as a slow change in the beam signal, the microcomputer compensates in such a manner that the signal moves closer to the reference data at a rate of approximately 1% per hour. When this compensating capability reaches a limit, the microprocessor automatically generates a trouble signal.

APPROVALS

U.L. (STD 268)
Factory Mutual

S1383
1Y0A5.AY



FEATURES

- **Use with any FCI or Other U.L. Listed Control**
- **Operation Unaffected by Air Velocity**
- **Three Field Adjustable Sensitivity Settings: 25%, 50% and 70%**
- **Form "A" Alarm Contacts**
- **Form "B" Trouble Contacts**
- **Four-wire Configuration**
- **Low Supervisory Current**
- **Calibrated Filters available to Verify Sensitivity**

Fire Control Instruments

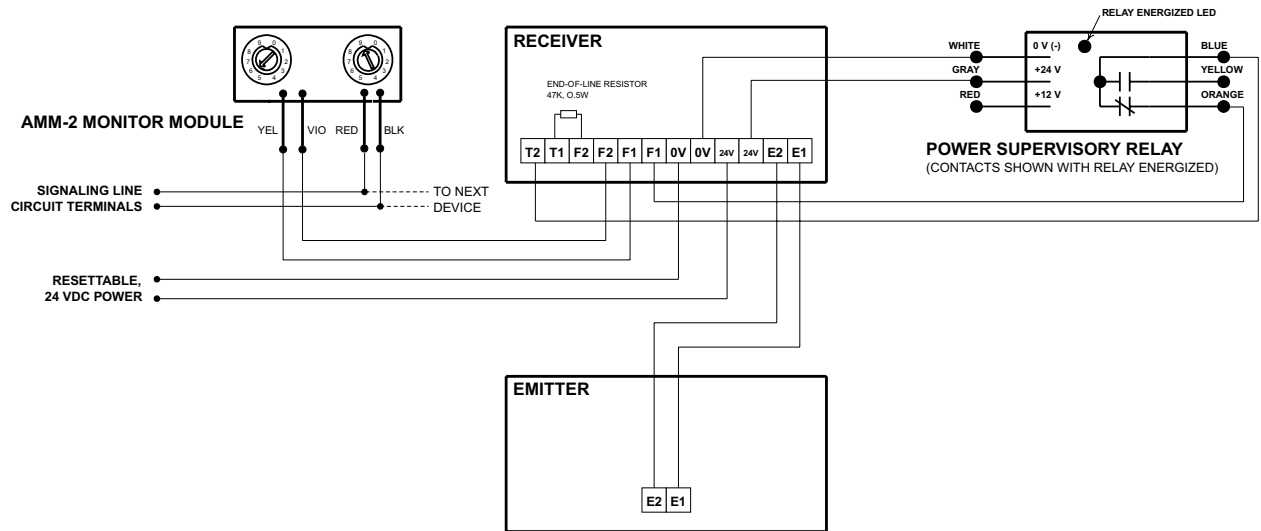

Typical Wiring Diagram

ALIGNMENT

Due to the wide angle of the beam, alignment is usually uncomplicated. The SPB detector employs signal strength indicating LEDs. Alignment is facilitated by turning an alignment adjustment wheel and monitoring the relative signal strength based upon which LED is lit.

MOUNTING

The SPB may be wall mounted on a single gang electrical box.

TECHNICAL INFORMATION

Rated voltage	24 VDC
Operating voltage range	15 - 33 VDC (42 V peak)
Current	
Supervisory	250 uA (average)
Alarm	.020 A
Operating temperature	14° F to 122° F (non-condensing)
Dimensions	3.4" W x 4.0" D x 5.7" H

ORDERING INFORMATION

Part Number	Model	Description
112-90006	SPB-24	Complete system includes emitter and receiver
112-90007		Test filter set