

TRANSISTOR (NPN)

FEATURES

- High Breakdown Voltage
- Complements the 2SA1579

MAXIMUM RATINGS (T_a=25°C unless otherwise noted)

Symbol	Parameter	Value	Unit
V _{CB0}	Collector-Base Voltage	120	V
V _{CEO}	Collector-Emitter Voltage	120	V
V _{EBO}	Emitter-Base Voltage	5	V
I _C	Collector Current	50	mA
P _C	Collector Power Dissipation	200	mW
R _{θJA}	Thermal Resistance From Junction To Ambient	625	°C/W
T _J	Junction Temperature	150	°C
T _{stg}	Storage Temperature	-55~+150	°C

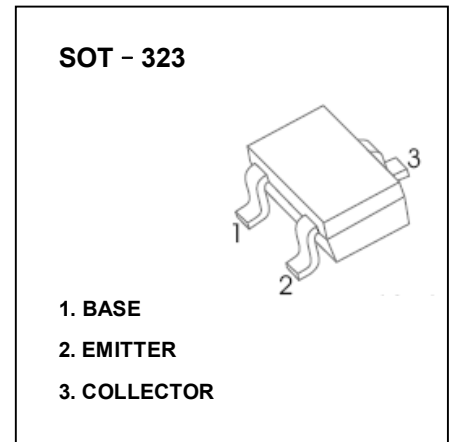

ELECTRICAL CHARACTERISTICS (T_a=25°C unless otherwise specified)

Parameter	Symbol	Test conditions	Min	Typ	Max	Unit
Collector-base breakdown voltage	V _{(BR)CBO}	I _C =50μA, I _E =0	120			V
Collector-emitter breakdown voltage	V _{(BR)CEO}	I _C =1mA, I _B =0	120			V
Emitter-base breakdown voltage	V _{(BR)EBO}	I _E =50μA, I _C =0	5			V
Collector cut-off current	I _{CBO}	V _{CB} =100V, I _E =0			500	nA
Emitter cut-off current	I _{EBO}	V _{EB} =4V, I _C =0			500	nA
DC current gain	h _{FE}	V _{CE} =6V, I _C =2mA	180		560	
Collector-emitter saturation voltage	V _{CE(sat)}	I _C =10mA, I _B =1mA			0.5	V
Transition frequency	f _T	V _{CE} =12V, I _C =2mA, f=100MHz		140		MHz
Collector output capacitance	C _{ob}	V _{CB} =12V, I _E =0, f=1MHz		2.5		pF

CLASSIFICATION OF h_{FE}

RANK	R	S
RANGE	180 - 390	270 - 560
MARKING	TR	TS