

T transition with self-locking feature for ease of assembly and repair for multi-legged conduit assemblies. Use H code conduit fittings to interface.



How To Order

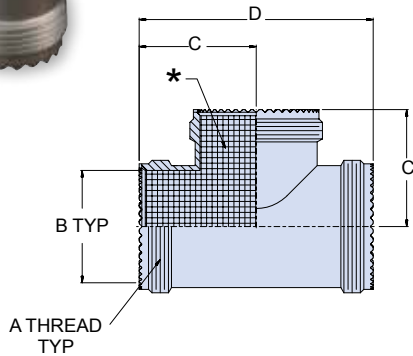
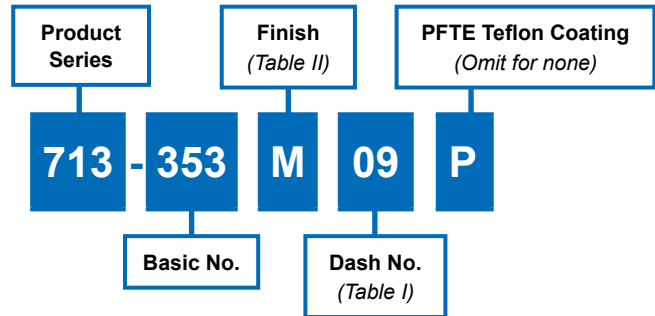

Table II		
Sym	Material	Finish Description
M	Aluminum	Electroless Nickel
MT		Nickel-PTFE
NF		Cad/Olive Drab over Electroless Nickel
ZN		Zinc Nickel/Olive Drab over Electroless Nickel
ZNU		Zinc Nickel/Black over Electroless Nickel
Z1	Stainless Steel	Passivate

Table I					
Dash No	Conduit Size (Ref)	A Thread Iso Metric	B Dia	C Max	D Max
09	06,09	M12 X 1.0-6g	.281 (7.1)	.78 (19.8)	1.53 (38.9)
11	10,12	M15 X 1.0-6g	.397 (10.1)	.90 (22.9)	1.71 (43.4)
13	14,16	M18 X 1.0-6g	.511 (13.0)	.94 (23.9)	1.84 (46.7)
15	20	M22 X 1.0-6g	.636 (16.2)	1.00 (25.4)	1.96 (49.8)
17	24	M25 X 1.0-6g	.761 (19.3)	1.08 (27.4)	2.12 (53.8)
19	28	M28 X 1.0-6g	.875 (22.2)	1.13 (28.7)	2.23 (56.6)
21	32	M31 X 1.0-6g	1.000 (25.4)	1.19 (30.2)	2.34 (59.4)
23	36	M34 X 1.0-6g	1.125 (28.6)	1.25 (31.8)	2.46 (62.5)
25	40	M37 X 1.0-6g	1.250 (31.8)	1.31 (33.3)	2.59 (65.8)
33	48	M45 X 1.5-6g	1.530 (38.9)	1.49 (37.8)	2.95 (74.9)
37	56	M50 X 1.5-6g	1.750 (44.5)	1.62 (41.1)	3.21 (81.5)

Material and Finish

See Table II.

*Internal Surface coated with Teflon as shown, see P/N development.