

## Evaluation Board for Dual High Speed Differential Amplifiers

### FEATURES

- Enables quick breadboarding/prototyping**
- User-defined circuit configuration**
- Edge-mounted SMA connector provisions**
- Easy connection to test equipment and other circuits**
- Two independent circuits enhance flexibility**

### GENERAL DESCRIPTION

The EB-D24CP44-2Z is designed, to aid in the evaluation of dual high speed differential amplifiers. The EB-D24CP44-2Z is a bare board (that is, there are no components soldered to the board) that enables users to quickly prototype a variety of differential amplifier circuits, which minimizes risk and reduces time to market. The EB-D24CP44-2Z evaluation board supports any of Analog Devices, Inc., dual high speed differential amplifiers in 4 mm × 4 mm lead frame chip scale packages (LFCSP).

Figure 1 shows the component side and circuit side of the evaluation board. Figure 2 shows the evaluation board schematic.

The 4-layer evaluation board accepts edge-mounted SMA connectors on both inputs and outputs, which allows efficient and quick connection to test equipment or other circuitry.

The board ground plane, component placement, and power supply bypassing have been optimized for maximum circuit flexibility and performance. The evaluation board uses a variety of SMT component case sizes: 0402, 0508, 0805, and 7343.

Figure 3 and Figure 5 show the evaluation board assembly drawings. The metal layout pattern for connecting the board to the op amp and to the supporting circuitry is shown in Figure 4 and Figure 6.

### DIGITAL PICTURE OF THE EVALUATION BOARD

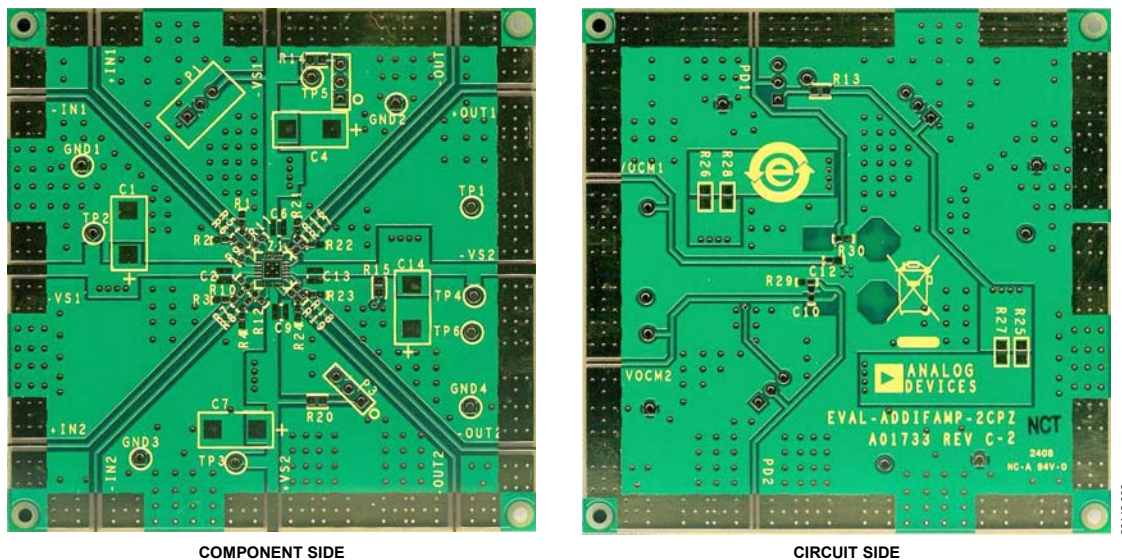

#### NOTES

1. THE EVALUATION BOARD SILKSCREEN PART NUMBER LABELING ON YOUR BOARD MAY BE DIFFERENT FROM WHAT IS SHOWN HERE.

Figure 1. Component and Circuit Side of PCB

**TABLE OF CONTENTS**

Features .....	1	Evaluation Board Schematic .....	3
General Description .....	1	Assembly Drawing and Board Layout .....	4
Digital Picture of the Evaluation Board.....	1	ESD Caution.....	4
Revision History .....	2		

**REVISION HISTORY**

**2/10—Rev. 0 to Rev. A**

Changes to General Description and Figure 1 ..... 1

**7/09—Revision 0: Initial Version**

EVALUATION BOARD SCHEMATIC

100-2-001

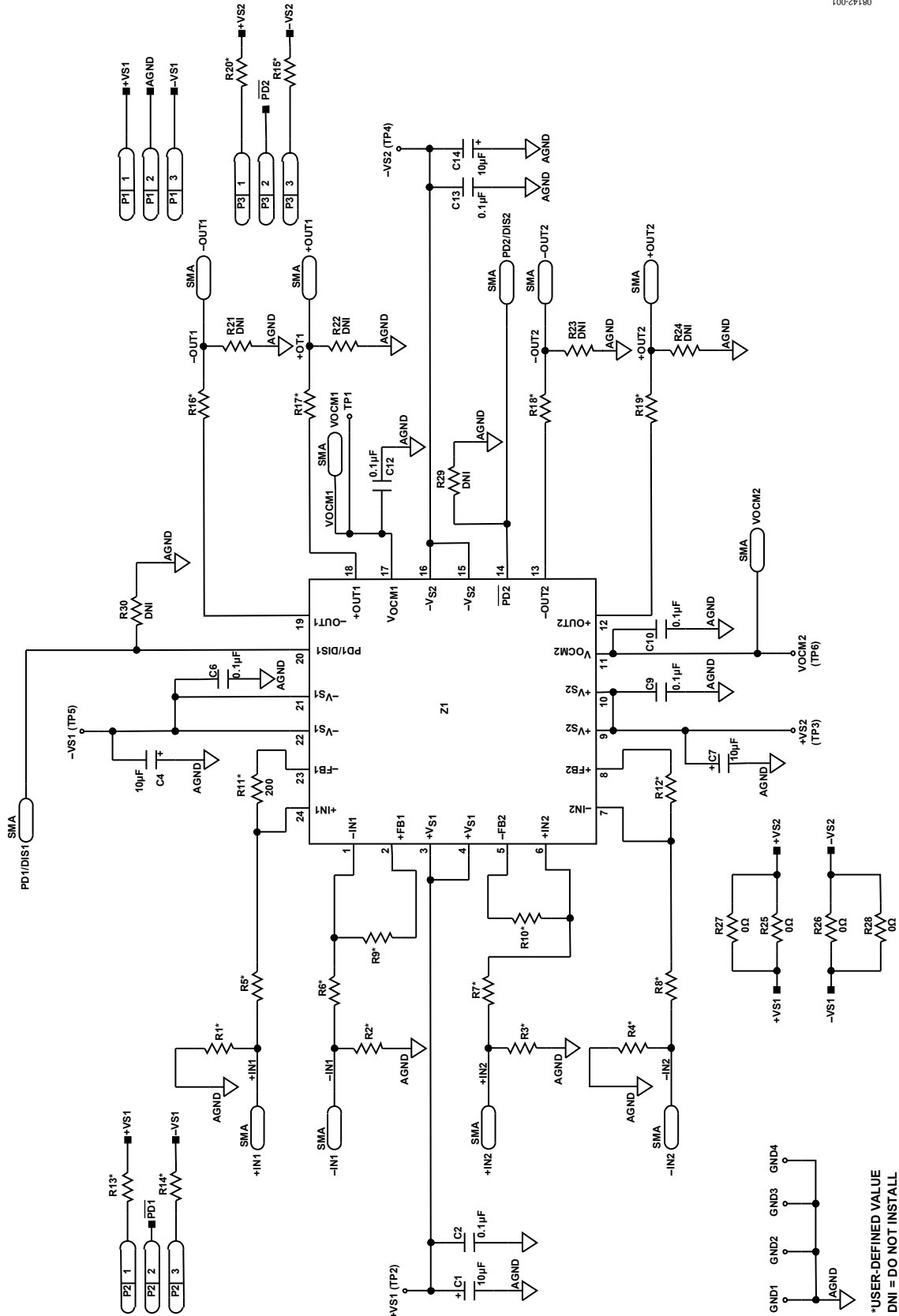

Figure 2. Dual Differential Amplifier Universal Evaluation Board Schematic

ASSEMBLY DRAWING AND BOARD LAYOUT

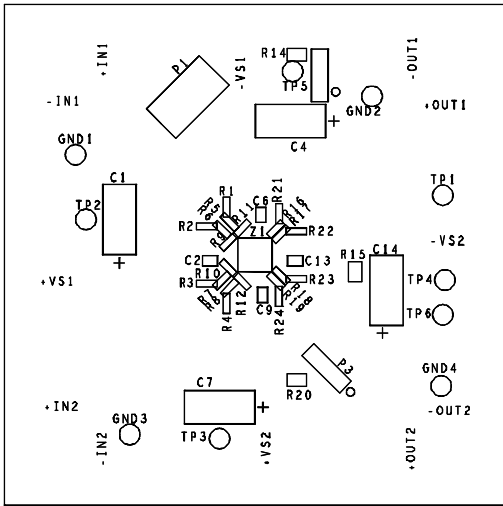

Figure 3. Board Assembly Drawing, Component Side

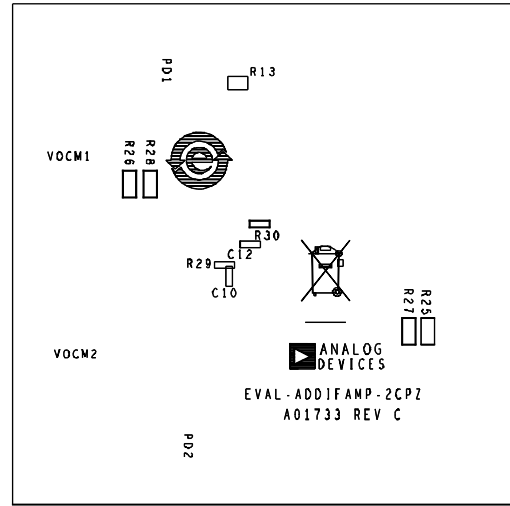

Figure 5. Board Assembly Drawing, Circuit Side

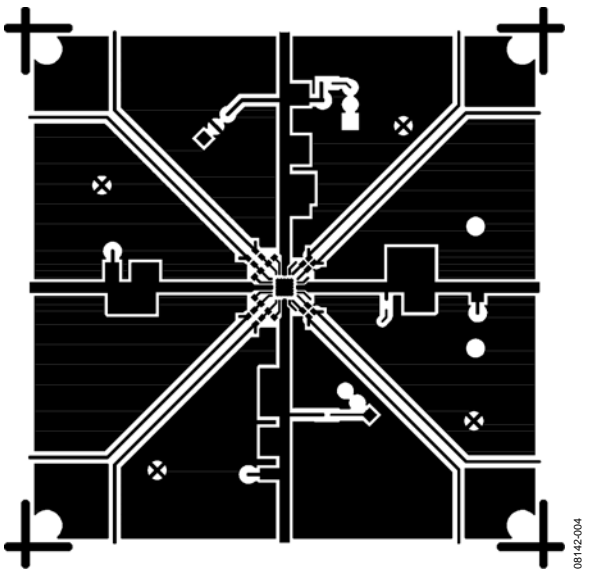

Figure 4. Board Layout Pattern, Component Side

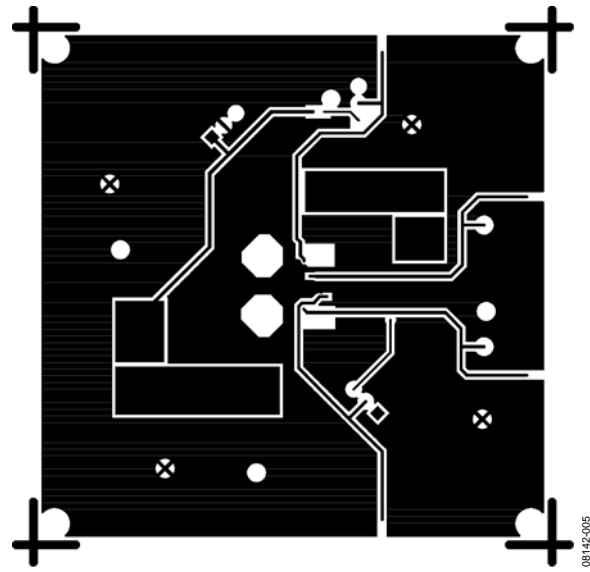

Figure 6. Board Layout Pattern, Circuit Side

ESD CAUTION



**ESD (electrostatic discharge) sensitive device.** Charged devices and circuit boards can discharge without detection. Although this product features patented or proprietary protection circuitry, damage may occur on devices subjected to high energy ESD. Therefore, proper ESD precautions should be taken to avoid performance degradation or loss of functionality.

Evaluation boards are only intended for device evaluation and not for production purposes. Evaluation boards are supplied “as is” and without warranties of any kind, express, implied, or statutory including, but not limited to, any implied warranty of merchantability or fitness for a particular purpose. No license is granted by implication or otherwise under any patents or other intellectual property by application or use of evaluation boards. Information furnished by Analog Devices is believed to be accurate and reliable. However, no responsibility is assumed by Analog Devices for its use, nor for any infringements of patents or other rights of third parties that may result from its use. Analog Devices reserves the right to change devices or specifications at any time without notice. Trademarks and registered trademarks are the property of their respective owners. Evaluation boards are not authorized to be used in life support devices or systems.

©2010 Analog Devices, Inc. All rights reserved. Trademarks and registered trademarks are the property of their respective owners. UG08142-0-2/10(A)



www.analog.com