

## Advanced HD decoder

Data brief

### Features

- Advanced high-definition video decoding (H264/VC-1/MPEG2/AVS)
- Advanced standard-definition video decoding (H264/VC-1/MPEG2/AVS)
- Advanced multichannel audio decoding (MPEG 1, 2, MP3, DD/DD+, AAC/AAC+, WMA9/WMA9pro, Dolby TrueHD, DTS/DTS-HD/DTS-HD master)
- Linux, Windows CE, and OS21 compatible ST40 applications CPU (450 MHz)
- 16/32-bit DDR2 compatible local memory interface
- Multistream, DVR capable transport stream processing
- Extensive connectivity (dual USB hosts, dual e-SATA, Ethernet MAC/MII/RMII/GMII, 2<sup>nd</sup> Ethernet MAC/MII/RMII, MMC/SD/SDIO, and PCI)
- Advance security and DRM support including SVP, MS-DRM, DivX, and DTCP-IP
- BD/DVD data decryption and advanced content protection

### Description

The STi7106 uses ST's state of the art process technology to provide a fully featured HD AVC decoder IC.

It is a highly integrated system-on-chip suitable for STB markets across all networks (cable/satellite/DTT/x-DSL/IP) worldwide.

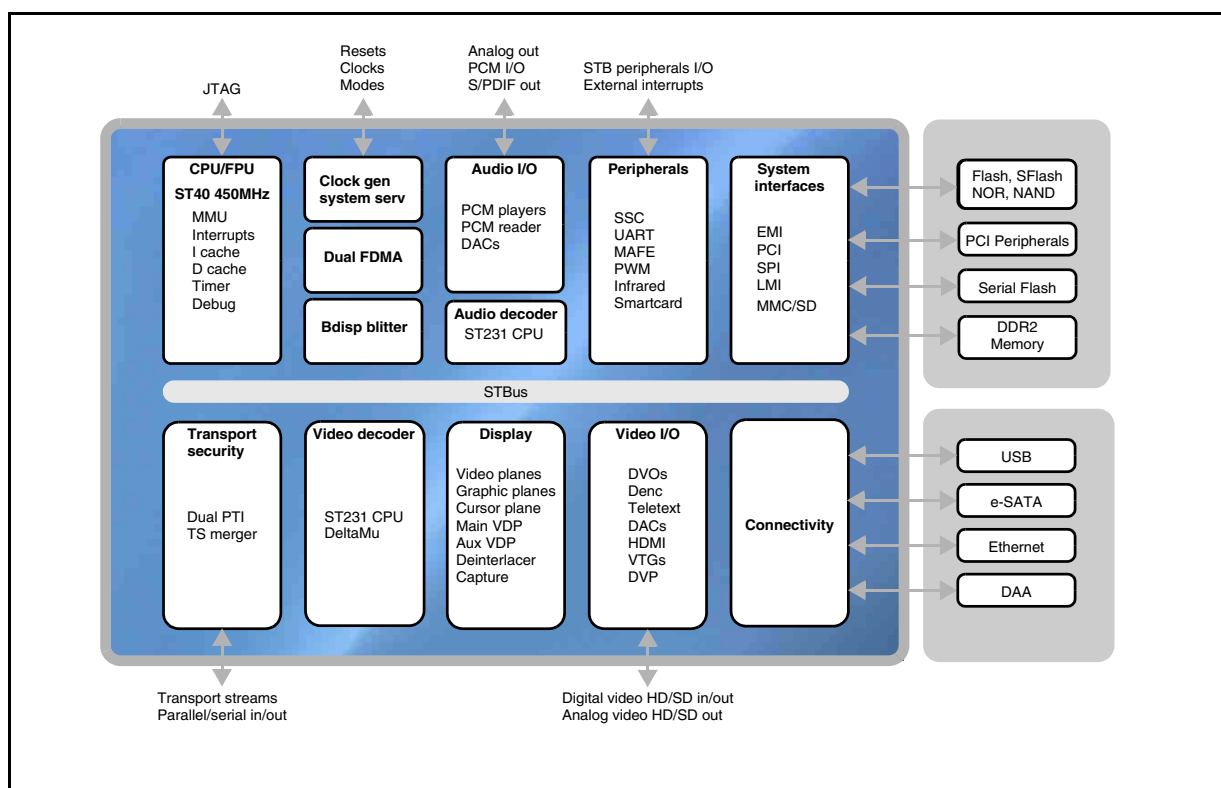

# 1 Introduction

The STi7106 is targeted at the latest operator and CE manufacturer requirements for STBs and Blu-ray DVD players, which utilize advanced HD decoding (H264/VC-1/MPEG2/AVS), and which conform to DVB, ISMA, ATIS-IIF, SCTE, DirecTV, ATSC, ARIB, CEA, ITU, OpenCable, MSTV, and BD specifications.

The STi7106 provides a solution for operators to specify a range of cost-efficient, high performance HD STBs including cost-efficient zappers, IP clients, interactive STBs, DVR standalone and DVR server/home network capable STBs, and with content delivery possible using broadcast or broadband networks, or both (hybrid STBs).

The STi7106 keeps pace with the latest conditional access, DRM and trusted platform requirements of major operators worldwide by incorporating the latest generation of advanced security features.

The STi7106 offers current users of ST's growing family of advanced decoding ICs enhancements in performance and features whilst reducing cost and time to market for the next generation deployments.

Features	Benefits
NAND Flash or Serial Flash based secure boot and code storage	Enables further BOM optimization and cost reduction of advanced decoding HD STBs
ST40-300 applications CPU @450MHz, 32 KI cache, 32 KD cache	Up to 800 DMIPs superscalar performance from a single CPU core using standard tools and operating systems (Linux, OS21)
ST's Delta decoding system with ST231 processor	Decoding of advanced high definition standards for broadcast (MPEG2, H264, VC-1, and AVS for China markets) plus performance and flexibility for web-based content decoding such as Flash, DivX, MJPEG and Real
Dual USB 2.0 hosts, Dual e-SATA, PCI, SD-MMC/SDIO, 10/100 Ethernet MAC/MII and a 10/100/1000 Ethernet MAC with MII/RMII/TMII and GMII interfaces	Extensive high speed connectivity for attaching to the widest range of STB peripherals, such as Flash drives, internal and external HDDs, home network controllers (e.g. MoCA, Wi-Fi, HomePlug), DOCSIS modem, memory cards and support for Gigabit Ethernet interfacing
Low power process, design and architecture	Best in class lowest power standby mode to meet emerging energy standards for STBs. Dynamic configuration of power to individual subsystems enables power efficient active standby modes
Advanced 2D graphics and display subsystem with Tile RAM bandwidth saver supports also 3D user interface effects	Allows more visually appealing program guides, user interfaces and video rich navigation to be offered to consumers
1080p60 display output with deep color support over HDMI 1.3	High quality progressive output can be watched on the latest high definition displays with enhanced color vividness

## 1.1 STi7106 features summary

The STi7106 has the following main features:

### CPU

- High performance CPUs for applications (ST40) and audio/video decoding (2 x ST231)
  - ST40-300, dual-issue, applications CPU, 32 KI, 32 KD caches, MMU, FPU
  - Target speed 450 MHz delivering > 800 DMIPs

### System and memory interfaces

- Single 16/32-bit DDR2 local memory interface (LMI), up to 400 MHz
- 16-bit external memory and peripheral interface (EMI) - up to five banks
- Interfacing to, and boot from, parallel NOR or NAND Flash
- High speed SPI port for interfacing to and boot from Serial Flash
  - Supports standard SPI and dual I/O protocols
- MMC 4.2/SD 2.0 interface
- 32-bit, 33 MHz, PCI interface, shared on EMI with access interleaving possible
- Disc-less timeslip feature supported via NAND Flash (raw or managed) attached to EMI, USB, or MMC interfaces

### Video decoding

- Latest generation “Delta” video decoder with ST231 programmable CPU core:
  - MPEG2, H264, VC-1/WM9, HD or SD advanced video decoding
  - AVS HD/SD decoding
  - Provides flexibility to support other codecs (DivX, XviD, H263 encode/decode, Flash, Real, MJPEG)
  - HD and SD decoding or dual SD decoding, PIP & Mosaic capable
  - Real-time transcoding of MPEG2 SD to H264 SIF
- Advanced deblocking, mosquito noise reduction of decoded MPEG2 SD sources based on ST’s digital source enhancer (DSE) technology with 2D analysis window and texture adaptive filter

### Audio

- ST231 CPU based audio decoder. MPEG1 I/II, MP3, Dolby Digital/DD+, MPEG4 AAC/AAC+, Dolby TrueHD, DTS, DTS-HD, DTS HD master audio multichannel audio decoding
  - Concurrent audio description decoding
  - DD+ and AAC+ transcoding
- Integrated stereo audio DAC
- 7.1-channel audio PCM output interface and separate stereo audio PCM output interface
- Stereo audio PCM input interface
- Independent SPDIF output

### Display and output

- Main and aux video display pipelines:
  - Main: high quality H & V reformatting/resizing with sample rate conversion/filtering. Motion and detail adaptive spatial and temporal deinterlacing for 480p/576p and 1080p60 progressive output; film mode detection
  - Aux: high quality H & V reformatting/resizing with sample rate conversion/filtering
- Three independent graphics planes with H & V resize, CLUT and anti-flicker filtering
- Link list based 2D graphics blitter
  - Up to 266 Mpixels/sec with destination alpha blending
  - Capable of high performance animated 3D user interface effects with tile RAM bandwidth saver enhancement
  - Run length decoding support for BD
- Independent main and aux display compositions (video/graphics mixing)
- Pass-through display for graphics, main video or aux video output concurrently with main and aux compositions
- HD display capture and down-conversion for concurrent HD and SD output of the main composition
- HDMI interface with HDCP copy protection (HD/ED/SD formats up to 1080p60)
  - Is in full compliance with all features of v1.3a, including deep color, enhanced colorimetry pass through (xvYCC, gamut metadata), 8 ch PCM, high bit rate (HBR) audio, and CEC
- Display output:
  - 16-bit digital video output (DVO) for main display composition (HD/ED/SD formats up to 1080p60)
  - Second 24-bit DVO for pass through display or main/aux display compositions (HD/ED/SD formats up to 1080p60)
  - Macrovision and Dwight Cavendish copy protection support
  - PAL/NTSC/SECAM digital encoder
  - Six 10-bit DACs for component/composite analog video output (HD/ED/SD formats up to 1080i)
- SD/HD digital video input port, 8- or 16-bit YCbCr

### Connectivity

- Dual USB 2.0 host interfaces both with PHY
- Integrated 10/100/1000 Ethernet GMAC, Wake-on-LAN, multiple h/w address filters
  - Supports 10/100 MII/RMII, Turbo-MII (TMII) up to 300 Mbits/sec and GMII up to 1000 Mbits/sec
- Second Ethernet MAC supporting 10/100 MII/RMII
- Soft modem support: integrated MAFE: integrated system side DAA (Si-Labs)

**Transport/security**

- Quadruple external TS inputs, triple internal TS from memory
- Dual DVB-CI+ (HD/SD profiles) modules supported
- Multistream transport stream demultiplexing, 400 Mbits/sec, quadruple tuner DVR capable
- DVB/DES/TDES/AES/Multi-2/ICAM descrambling
- DVR supported, with HDD attachment through e-SATA, EIDE (PIO mode) or USB
- CSS (DVD-video), CPRM (DVD-RW), and CPPM (DVD-audio) decryption is provided for the DVD stream
- Blu-ray DVD (BD) security: BD+/AACs
- Advanced security:
  - Secure control words
  - Secure boot with code authentication
  - JTAG locking
  - Network/DVR copy protection

**STB peripherals and package**

- On-chip STB peripherals:
  - Two smartcard interfaces
  - Four UARTs
  - Four SSC/I2C
  - GPIO banks with alternate functions
  - IR Tx/Rx
  - UHF Rx/SCD
  - PWM
  - ILC
  - HDMI CEC
  - 4 x 4 key matrix scanner
- Package:
  - FPGBA 27 x 27mm
  - 620 balls
  - Pitch 0.8 mm
  - Ball 0.5 mm
  - Ball to ball compatible with STi7105 with additional balls assigned
- Dual multichannel flexible DMA controllers

## 2 Target applications

The STi7106 integrates in a single IC, multistream transport demultiplexing, applications CPU, A/V decode, video processing, graphics and display, advanced security, STB peripherals, audio/video DACs, digital A/V outputs, HDMI, dual e-SATA ports, dual USB ports, dual Ethernet controllers (1x GbE capable) and MMC/SD/SDIO card controller.

**Figure 1. IP client HD STB (wired Ethernet or Wi-Fi connection)**

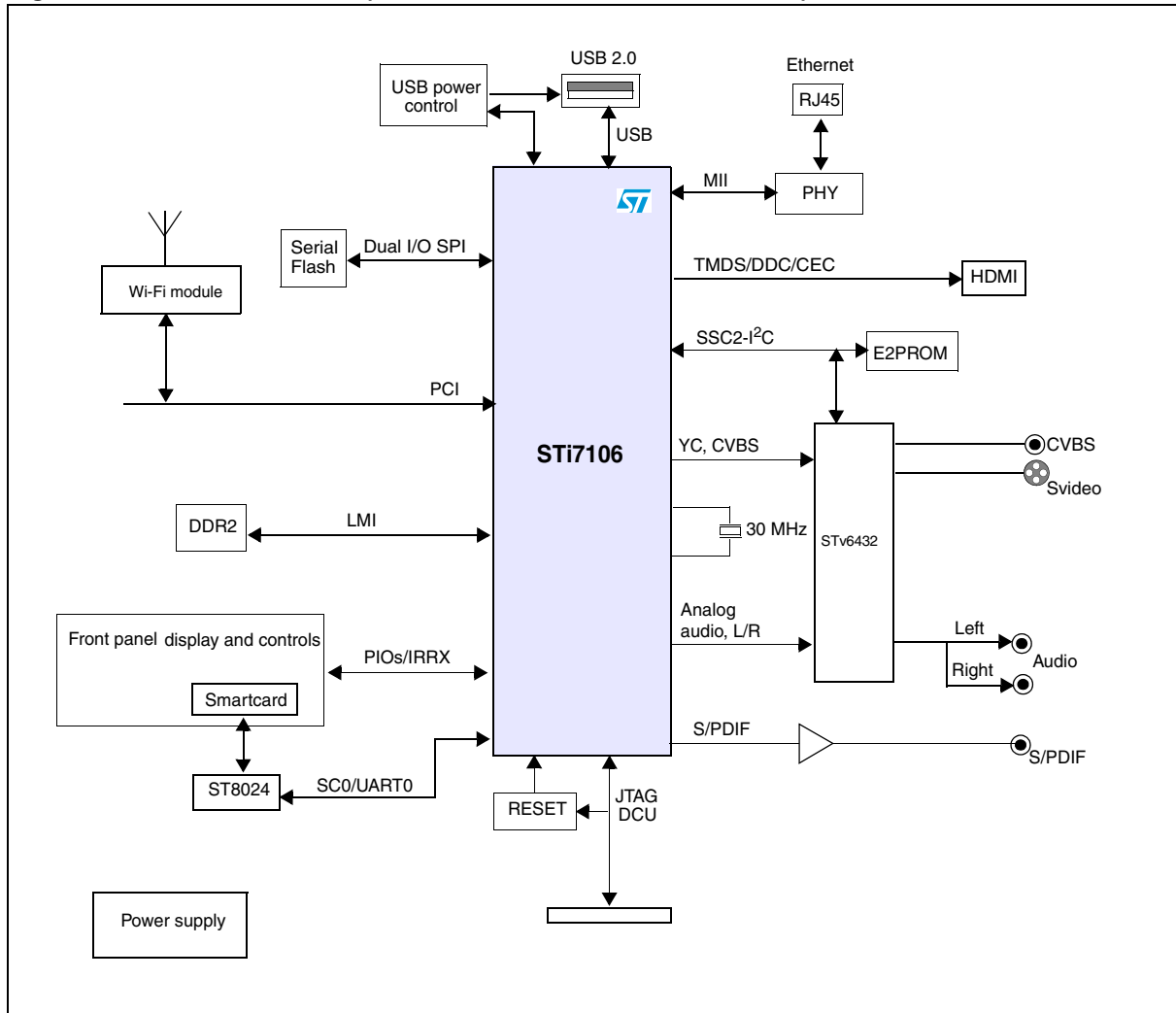

Figure 2. Hybrid DTT/IP HD STB

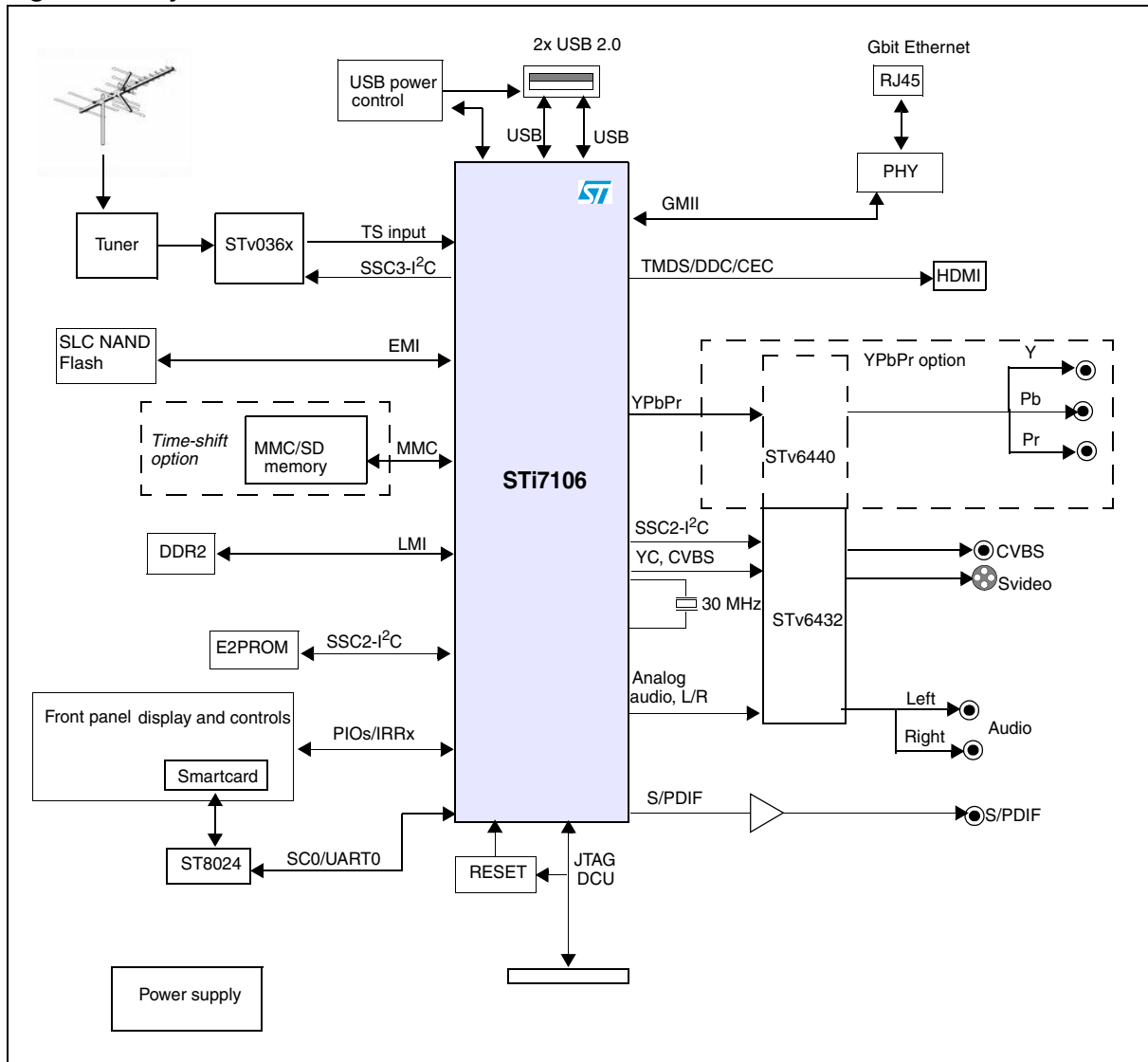

Figure 3. Dual tuner DVB-C/IP HD DVR STB with MoCA

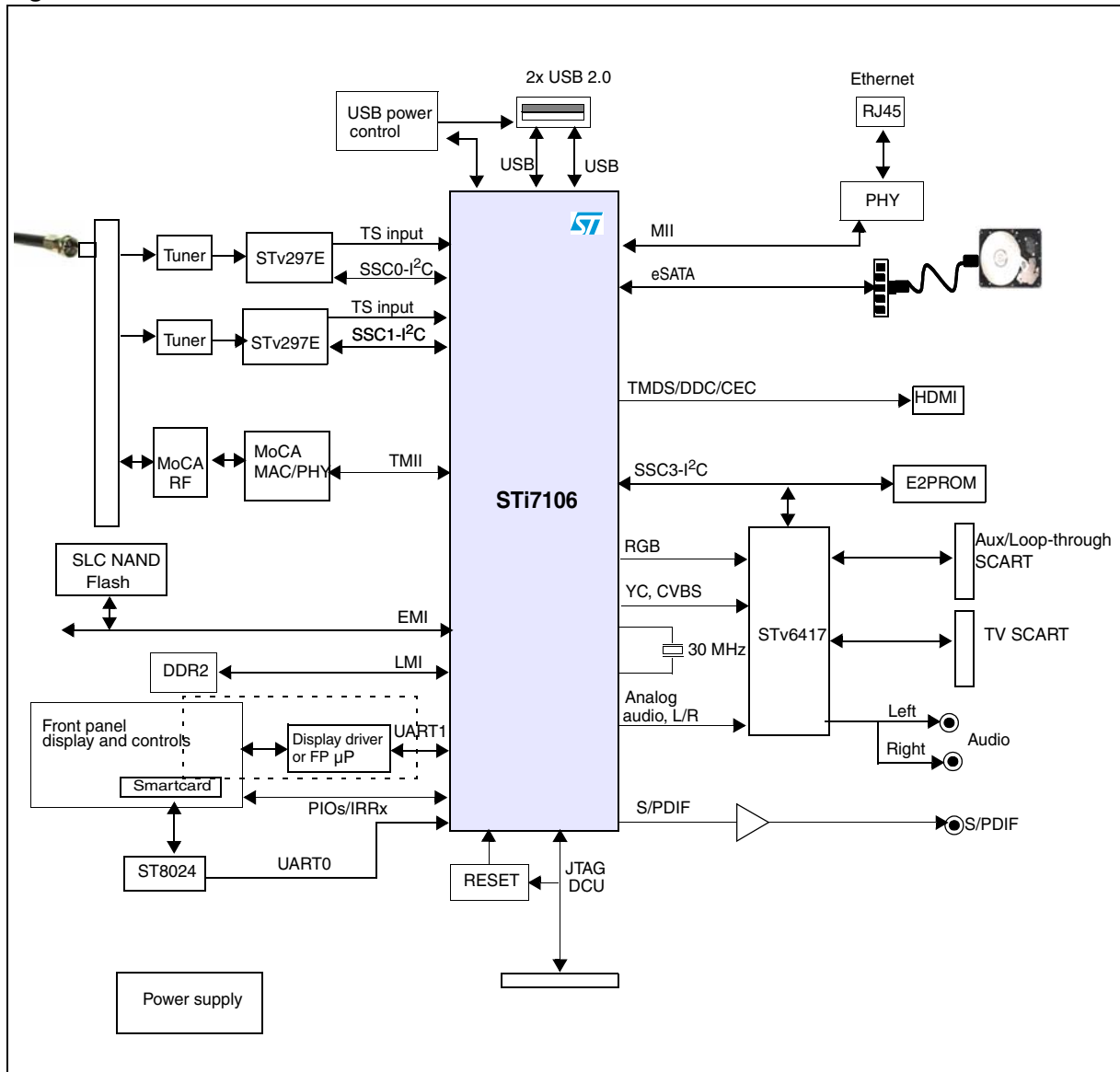



Figure 4. Multi tuner DVB-C/IP HD DVR STB with DOCSIS

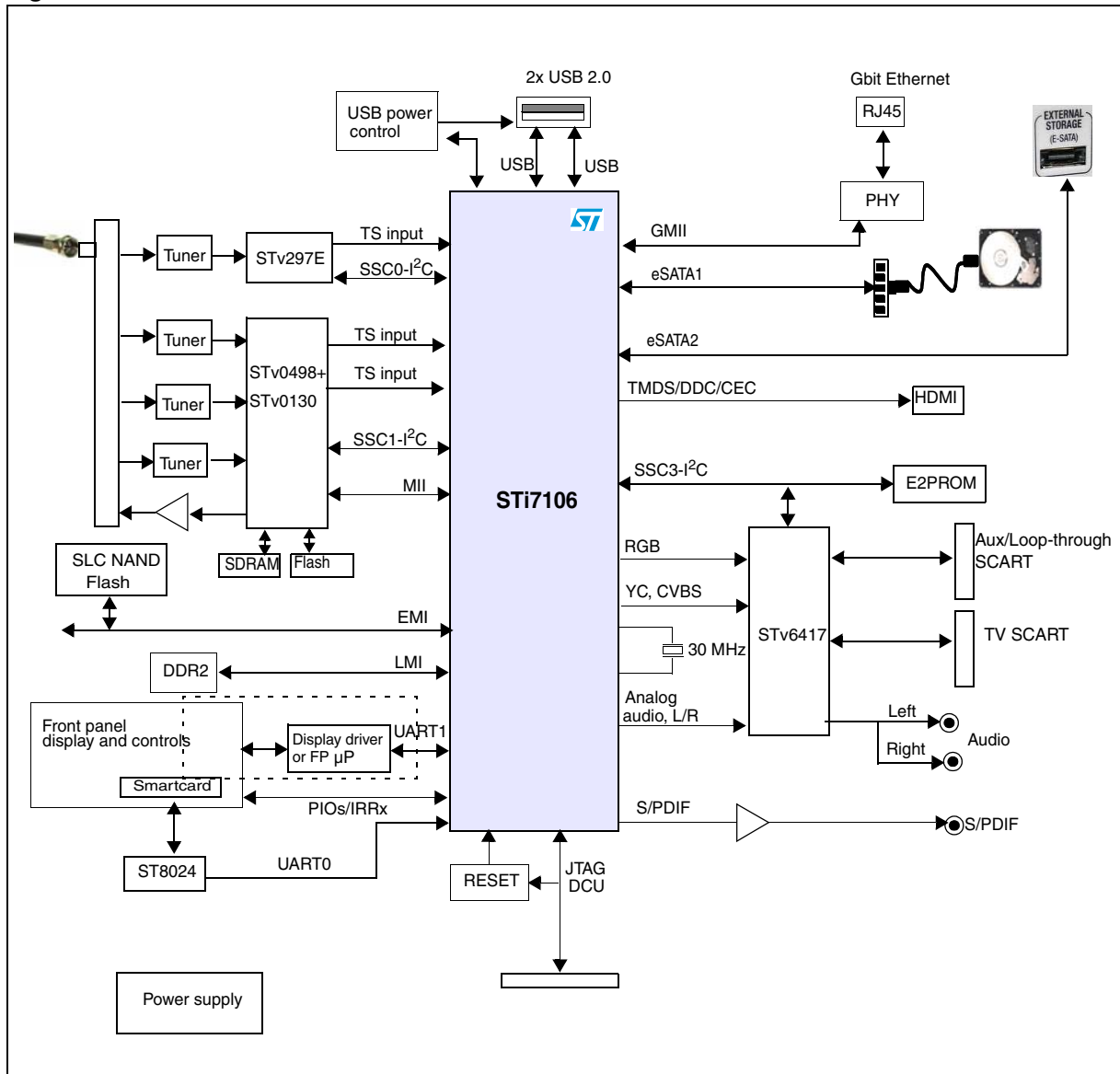
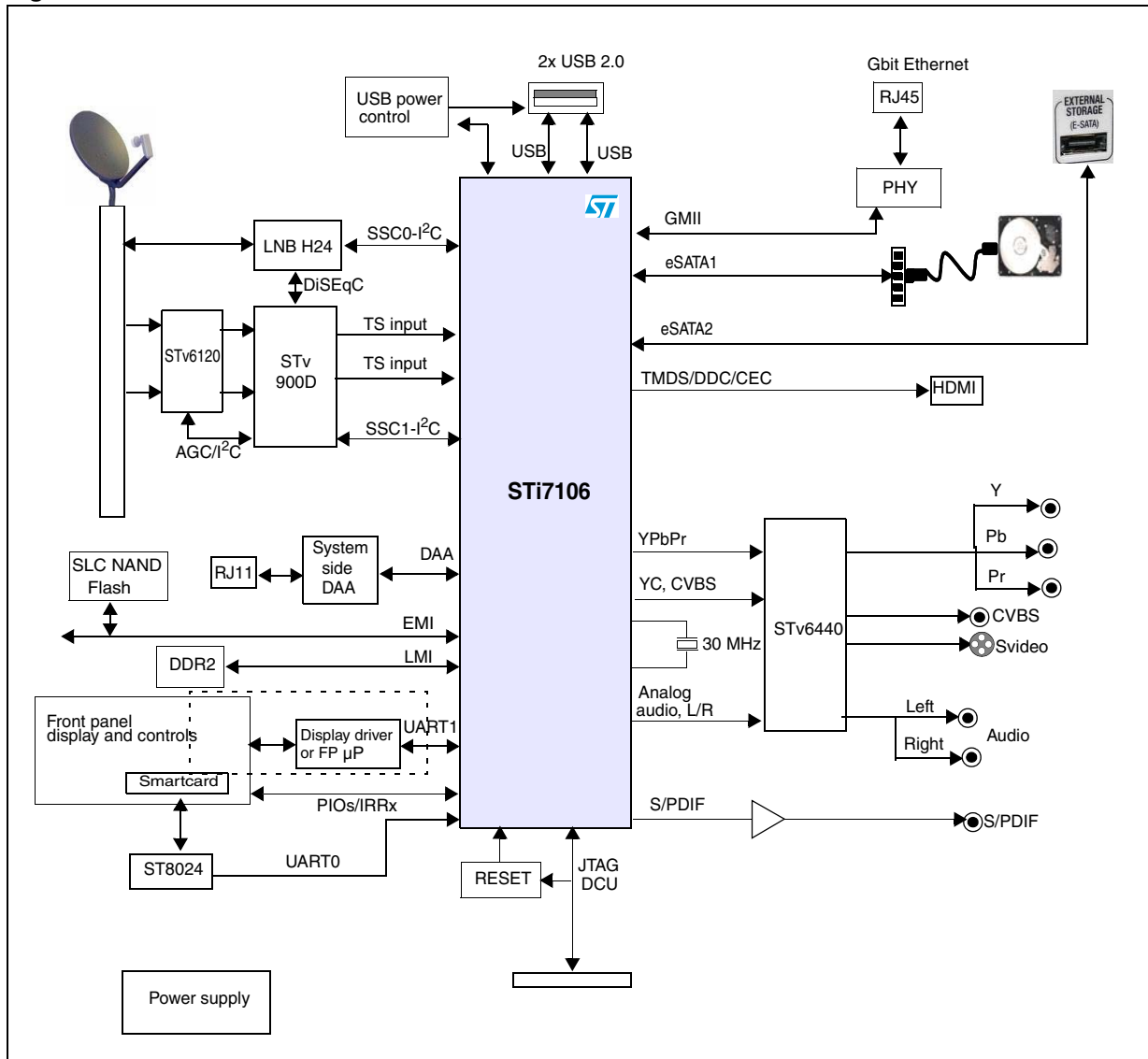

Figure 5. Dual tuner DVB-S2/IP HD DVR STB



### 3 Ordering information

Table 1. Ordering information

Order code	Packaging	Description
STi7106ZUA	FPBGA 27 x 27 mm	Development version, all options.

## 4 Revision history

**Table 2. Document revision history**

Date	Revision	Changes
29-Oct-2009	1	Initial release.

**Please Read Carefully:**

Information in this document is provided solely in connection with ST products. STMicroelectronics NV and its subsidiaries ("ST") reserve the right to make changes, corrections, modifications or improvements, to this document, and the products and services described herein at any time, without notice.

All ST products are sold pursuant to ST's terms and conditions of sale.

Purchasers are solely responsible for the choice, selection and use of the ST products and services described herein, and ST assumes no liability whatsoever relating to the choice, selection or use of the ST products and services described herein.

No license, express or implied, by estoppel or otherwise, to any intellectual property rights is granted under this document. If any part of this document refers to any third party products or services it shall not be deemed a license grant by ST for the use of such third party products or services, or any intellectual property contained therein or considered as a warranty covering the use in any manner whatsoever of such third party products or services or any intellectual property contained therein.

**UNLESS OTHERWISE SET FORTH IN ST'S TERMS AND CONDITIONS OF SALE ST DISCLAIMS ANY EXPRESS OR IMPLIED WARRANTY WITH RESPECT TO THE USE AND/OR SALE OF ST PRODUCTS INCLUDING WITHOUT LIMITATION IMPLIED WARRANTIES OF MERCHANTABILITY, FITNESS FOR A PARTICULAR PURPOSE (AND THEIR EQUIVALENTS UNDER THE LAWS OF ANY JURISDICTION), OR INFRINGEMENT OF ANY PATENT, COPYRIGHT OR OTHER INTELLECTUAL PROPERTY RIGHT.**

**UNLESS EXPRESSLY APPROVED IN WRITING BY AN AUTHORIZED ST REPRESENTATIVE, ST PRODUCTS ARE NOT RECOMMENDED, AUTHORIZED OR WARRANTED FOR USE IN MILITARY, AIR CRAFT, SPACE, LIFE SAVING, OR LIFE SUSTAINING APPLICATIONS, NOR IN PRODUCTS OR SYSTEMS WHERE FAILURE OR MALFUNCTION MAY RESULT IN PERSONAL INJURY, DEATH, OR SEVERE PROPERTY OR ENVIRONMENTAL DAMAGE. ST PRODUCTS WHICH ARE NOT SPECIFIED AS "AUTOMOTIVE GRADE" MAY ONLY BE USED IN AUTOMOTIVE APPLICATIONS AT USER'S OWN RISK.**

Resale of ST products with provisions different from the statements and/or technical features set forth in this document shall immediately void any warranty granted by ST for the ST product or service described herein and shall not create or extend in any manner whatsoever, any liability of ST.

ST and the ST logo are trademarks or registered trademarks of ST in various countries.

Information in this document supersedes and replaces all information previously supplied.

The ST logo is a registered trademark of STMicroelectronics. All other names are the property of their respective owners.

© 2009 STMicroelectronics - All rights reserved

STMicroelectronics group of companies

Australia - Belgium - Brazil - Canada - China - Czech Republic - Finland - France - Germany - Hong Kong - India - Israel - Italy - Japan - Malaysia - Malta - Morocco - Philippines - Singapore - Spain - Sweden - Switzerland - United Kingdom - United States of America

[www.st.com](http://www.st.com)

