

3A, 24V, 3MHz Step-Down Converter

General Description

The RT8280 is a high voltage buck converter that can support an input voltage range from 4.5V to 24V with output current up to 3A. Current mode operation provides fast transient response and eases loop stabilization.

The chip provides protection functions such as cycle-by-cycle current limiting and thermal shutdown protection. In shutdown mode, the regulator only draws 25µA of supply current. The RT8280 is available in a SOP-8 (Exposed Pad) package.

Ordering Information

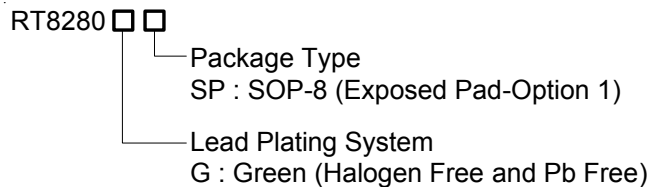

Note :

Richtek products are :

- ▶ RoHS compliant and compatible with the current requirements of IPC/JEDEC J-STD-020.
- ▶ Suitable for use in SnPb or Pb-free soldering processes.

Marking Information

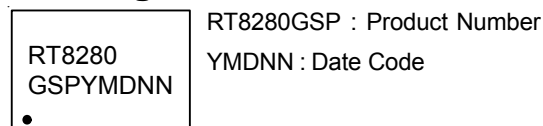

Features

- Wide Operating Input Range : 4.5V to 24V
- Adjustable Output Voltage Range : 0.8V to 15V
- Output Current up to 3A
- 25µA Low Shutdown Current
- High Efficiency up to 90% at 2.2MHz
- Programmable Frequency : 220kHz to 3MHz
- Internal Soft-Start
- Stable with Low ESR Output Ceramic Capacitors
- Thermal Shutdown Protection
- Cycle-By-Cycle Over Current Protection
- RoHS Compliant and Halogen Free

Applications

- DSL Modem for ADSL2+ Standard
- Distributed Power Systems
- Pre-Regulator for Linear Regulators

Pin Configurations

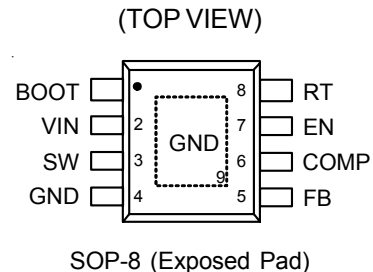

Typical Application Circuit

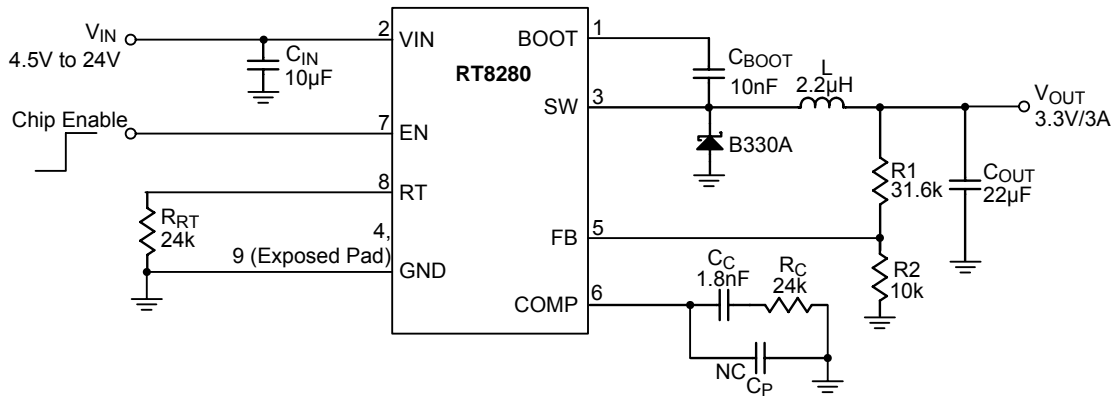

Table 1. Recommended Component Selection for $f_{sw} = 2.2\text{MHz}$

V _{OUT} (V)	R1 (kΩ)	R2 (kΩ)	R _C (kΩ)	C _C (nF)	L (µH)	C _{OUT} (µF)
10	115	10	68	0.82	8.2	22
8	91	10	51	1	6.8	22
5	52.3	10	36	1.2	4.7	22
3.3	31.6	10	24	1.8	2.2	22
2.5	21.5	10	18	2.2	2	22
1.8	12.4	10	13	2.2	1.5	22
1.5	8.87	10	12	2.2	1.5	22
1.2	4.99	10	9	1.8	1	22

Functional Pin Description

Pin No.	Pin Name	Pin Function
1	BOOT	Bootstrap Power. BOOT supplies the drive for the high side N-MOSFET switch. Connect a 10nF or greater capacitor from SW to BOOT to power the high side switch.
2	VIN	Supply Input. V _{IN} supplies the power to the IC, as well as the step-down converter switches. Drive V _{IN} with a 4.5V to 24V power source. Bypass V _{IN} to GND with a suitably large capacitor to eliminate noise on the input to the IC.
3	SW	Switch Node. SW is the switching node that supplies power to the output. Connect the output LC filter from SW to the output load. Note that a capacitor is required from SW to BOOT to power the high side switch.
4, 9 (Exposed Pad)	GND	Ground. The exposed pad must be soldered to a large PCB and connected to GND for maximum power dissipation.
5	FB	Feedback Input. FB senses the output voltage to regulate. Drive FB with a resistive voltage divider from the output voltage.
6	COMP	Compensation Node. COMP is used to compensate the regulation control loop. Connect a series RC network from COMP to GND to compensate the regulation control loop. In some cases, an additional capacitor from COMP to GND is required.
7	EN	Enable Input. EN is a digital input that turns the regulator on or off. Drive EN higher than 1.4V to turn on the regulator, lower than 0.4V to turn off. For automatic startup, leave EN unconnected.
8	RT	Oscillator Resistor Input. Connecting a resistor to ground from this pin sets the switching frequency.

Function Block Diagram

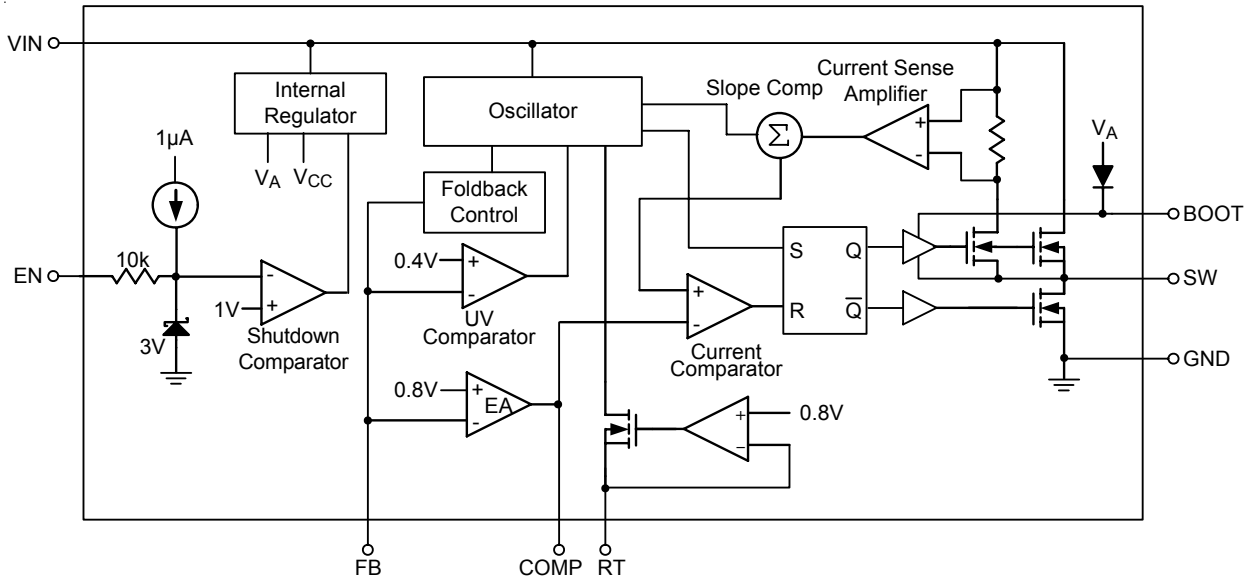

Absolute Maximum Ratings (Note 1)

- V_{IN} ----- -0.3V to 26V
- SW ----- -0.3V to ($V_{IN} + 0.3V$)
- BOOT ----- ($SW - 0.3V$) to ($SW + 6V$)
- All Other Pins ----- -0.3V to 6V
- Power Dissipation, P_D @ $T_A = 25^\circ C$
 SOP-8 (Exposed Pad) ----- 1.333W
- Package Thermal Resistance (Note 2)
 SOP-8 (Exposed Pad), θ_{JA} ----- $75^\circ C/W$
 SOP-8 (Exposed Pad), θ_{JC} ----- $15^\circ C/W$
- Lead Temperature (Soldering, 10 sec.) ----- $260^\circ C$
- Junction Temperature ----- $150^\circ C$
- Storage Temperature Range ----- $-65^\circ C$ to $150^\circ C$
- ESD Susceptibility (Note 3)
 HBM (Human Body Mode) ----- 2kV
 MM (Machine Mode) ----- 200V

Recommended Operating Conditions (Note 4)

- Supply Input Voltage, V_{IN} ----- 4.5V to 24V
- Junction Temperature Range ----- $-40^\circ C$ to $125^\circ C$
- Ambient Temperature Range ----- $-40^\circ C$ to $85^\circ C$

Electrical Characteristics

($V_{IN} = 12V$, $T_A = 25^\circ C$, unless otherwise specified)

Parameter	Symbol	Test Conditions	Min	Typ	Max	Unit
Feedback Reference Voltage	V_{FB}	$4.5V \leq V_{IN} \leq 24V$	0.784	0.8	0.816	V
Upper Switch On Resistance	$R_{DS(ON)1}$		--	0.11	--	Ω
Lower Switch On Resistance	$R_{DS(ON)2}$		--	10	--	Ω
Upper Switch Leakage	I_{LEAK}	$V_{EN} = 0V$, $V_{SW} = 0V$	--	0	10	μA
Current Limit	I_{LIM}	Duty = 90%, $V_{BOOT} - V_{SW} = 4.8V$	--	5	--	A
Current Sense Transconductance Output Current to Comp Pin Voltage	g_{CS}		--	3.8	--	A/V
Error Amplifier Transconductance	g_{EA}	$\Delta I_C = \pm 10\mu A$	--	920	--	$\mu A/V$
Oscillator Frequency	f_{SW}	$R_{RT} = 24k\Omega$	--	2.2	--	MHz
Short Circuit Frequency		$V_{FB} = 0V$, $R_{RT} = 24k\Omega$	--	230	--	kHz
Under Voltage Lockout Threshold Rising	V_{UVLO}		--	4.2	--	V
Under Voltage Lockout Threshold Hysteresis	ΔV_{UVLO}		--	430	--	mV
Maximum Duty Cycle	D_{MAX}	$V_{FB} = 0.7V$, $R_{RT} = 24k\Omega$	--	65	--	%
Minimum On Time	t_{ON}		--	70	--	ns

Parameter		Symbol	Test Conditions	Min	Typ	Max	Unit
EN Threshold Voltage	Logic-High	V_{IH}		1.4	--	5.5	V
	Logic-Low	V_{IL}		--	--	0.4	
Enable Pull Up Current				--	1	--	μA
Quiescent Current		I_Q	$V_{EN} = 2V, V_{FB} = 1V$	--	0.8	1	mA
Shutdown Current		I_{SHDN}	$V_{EN} = 0V$	--	25	--	μA
Thermal Shutdown				--	150	--	$^{\circ}C$

Note 1. Stresses beyond those listed “Absolute Maximum Ratings” may cause permanent damage to the device. These are stress ratings only, and functional operation of the device at these or any other conditions beyond those indicated in the operational sections of the specifications is not implied. Exposure to absolute maximum rating conditions may affect device reliability.

Note 2. θ_{JA} is measured at $T_A = 25^{\circ}C$ on a high effective thermal conductivity four-layer test board per JEDEC 51-7. θ_{JC} is measured at the exposed pad of the package.

Note 3. Devices are ESD sensitive. Handling precaution is recommended.

Note 4. The device is not guaranteed to function outside its operating conditions.

Typical Operating Characteristics

Efficiency vs. Output Current

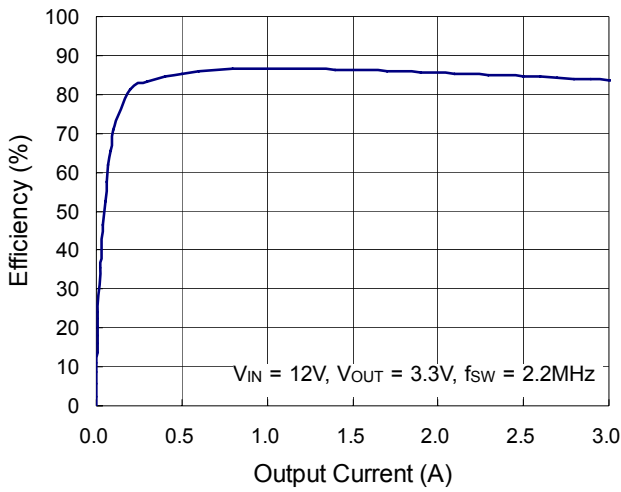

Efficiency vs. Output Current

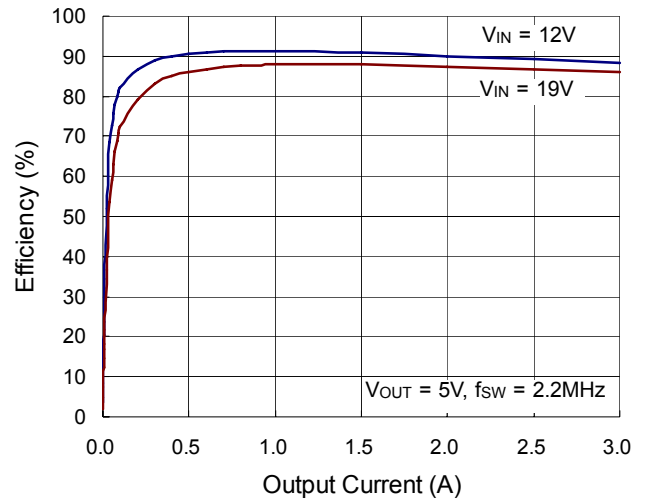

Output Voltage vs. Output Current

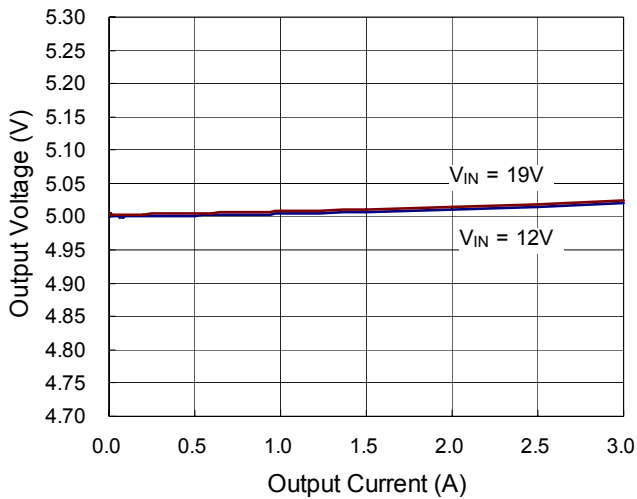

Output Voltage vs. Input Voltage

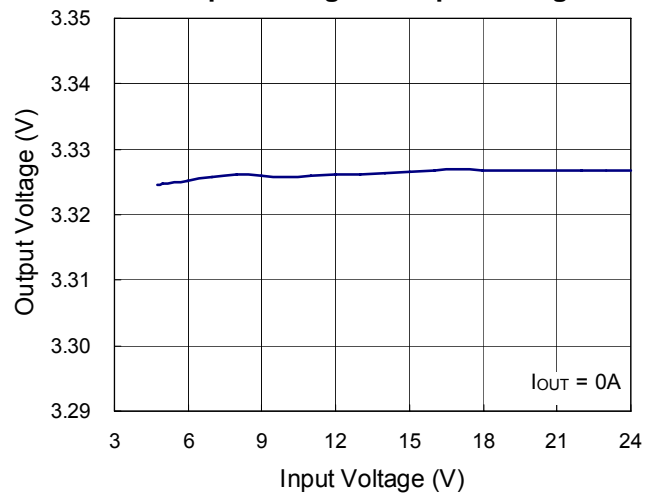

Reference Voltage vs. Temperature

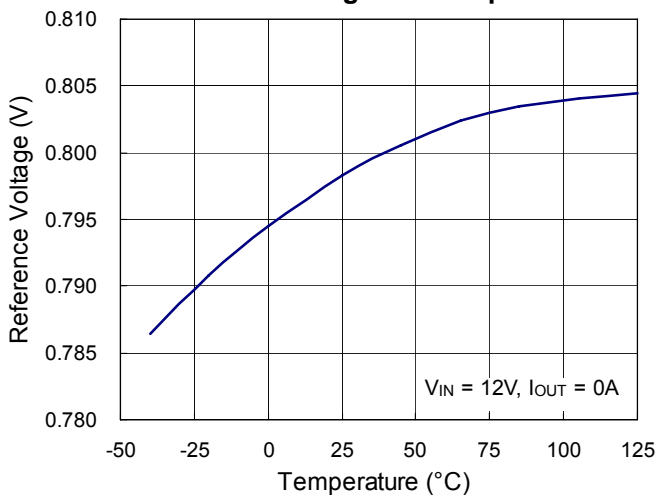

Quiescent Current vs. Temperature

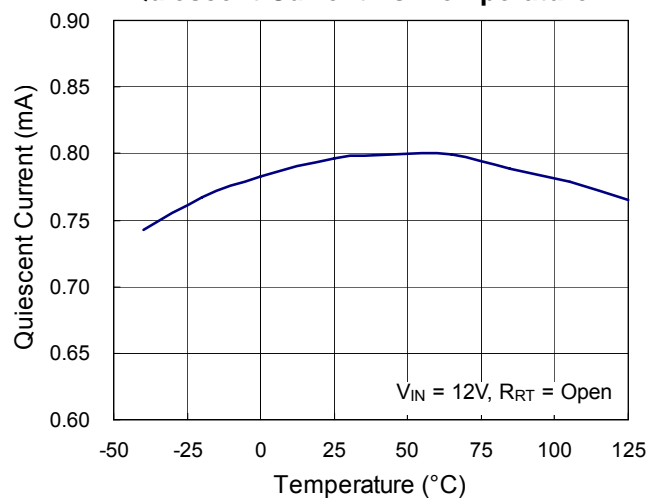

Current Limit vs. Duty Cycle

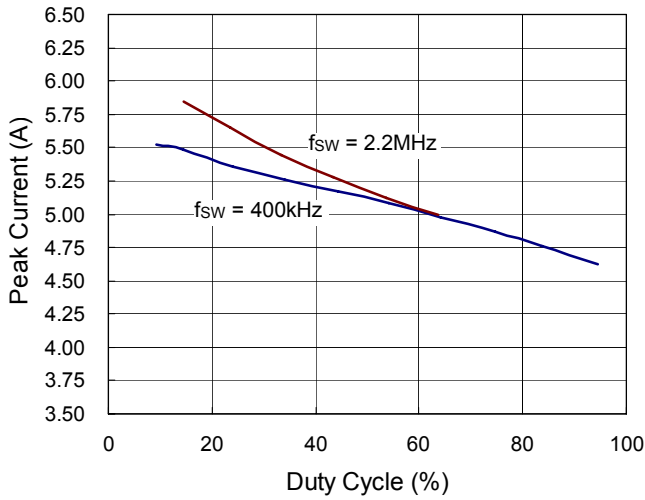

Current Limit vs. Temperature

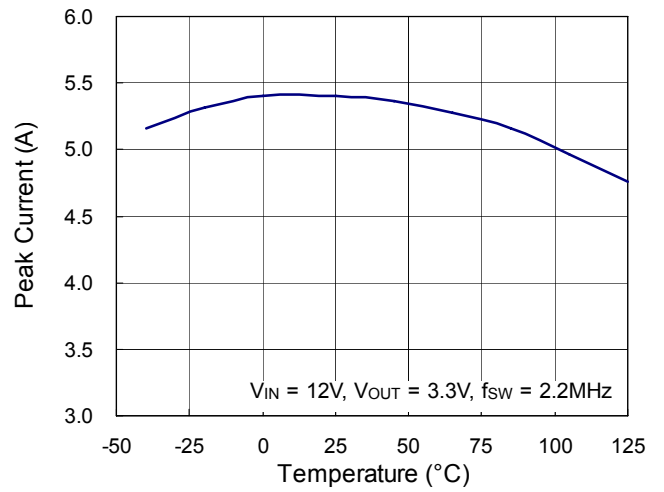

Switching Frequency vs. Temperature

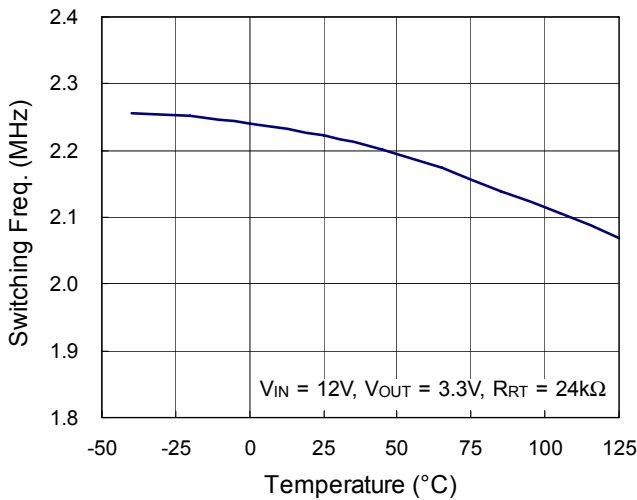

Output Ripple Voltage

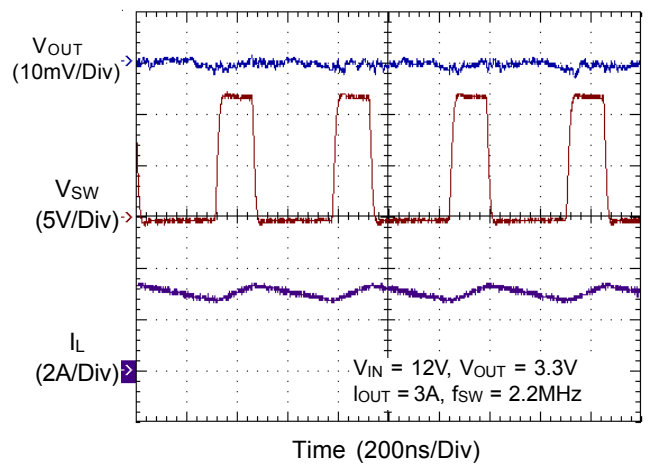

Load Transient Response

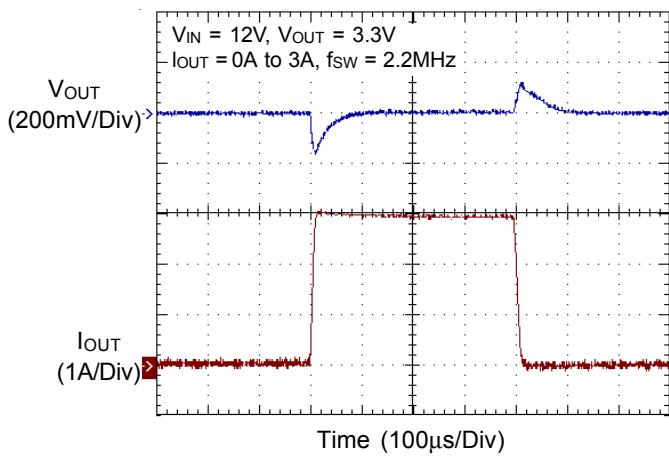

Load Transient Response

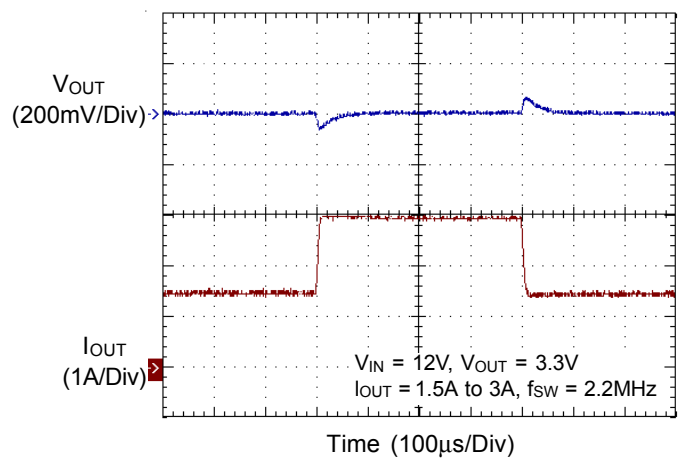

Power On from EN

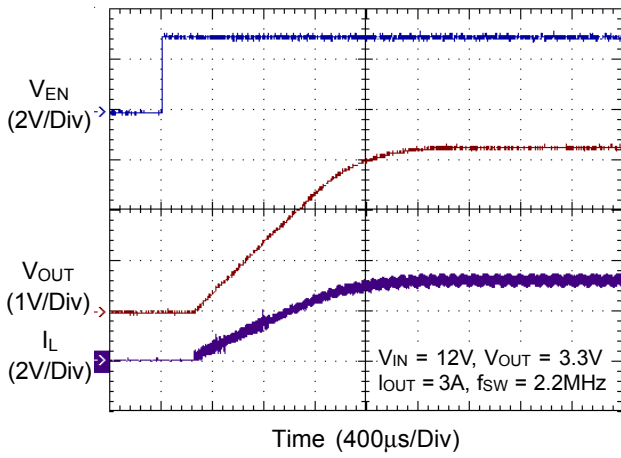

Power off from EN

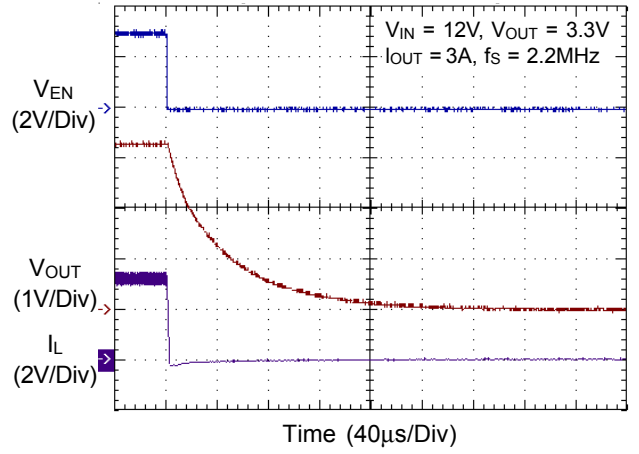

Application Information

The RT8280 is an asynchronous high voltage buck converter that supports an input voltage range from 4.5V to 24V with output current up to 3A.

Output Voltage Setting

The resistive voltage divider allows the FB pin to sense the output voltage as shown in Figure 1.

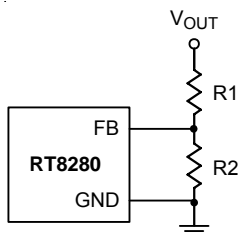

Figure 1. Output Voltage Setting

The output voltage is set by an external resistive voltage divider according to the following equation :

$$V_{OUT} = V_{FB} \left(1 + \frac{R1}{R2} \right)$$

where V_{FB} is the feedback reference voltage (0.8V typ.).

External Bootstrap Diode

Connect a 10nF low ESR ceramic capacitor between the BOOT pin and SW pin. This capacitor provides the gate driver voltage for the high side MOSFET.

It is recommended to add an external bootstrap diode between an external 5V voltage source and the BOOT pin for efficiency improvement when input voltage is lower than 5.5V or duty cycle is higher than 65% . The bootstrap diode can be a low cost one such as IN4148 or BAT54. The external voltage source must be fixed at 5V and can be provided from the system or the output of the RT8280. Note that the external boot voltage must be lower than 5.5V.

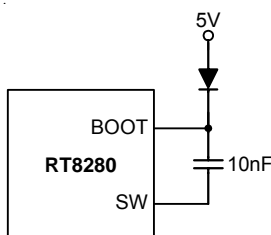

Figure 2. External Bootstrap Diode

Operating Frequency

Selection of the operating frequency is a trade off between efficiency and component size. High frequency operation allows the use of smaller inductor and capacitor values. Operation at lower frequency improves efficiency by reducing internal gate charge and switching losses, but requires larger inductance and/or capacitance to maintain low output ripple voltage. The operating frequency of the RT8280 is determined by an external resistor that is connected between the RT pin and ground. The value of the resistor sets the ramp current that is used to charge and discharge an internal timing capacitor within the oscillator. Selection of the RT resistor value can be determined by examining the curve below in Figure3. Although frequencies as high as 3MHz are available, the minimum on-time of the RT8280 imposes a limit on the operating duty cycle. Figure 4 shows the examples of minimum on-time constraint for output voltages 3.3V and 1.8V. It is recommended to operate the RT8280 in the region under the corresponding Vout curve.

Except the minimum on-time constraint, the limit of maximum duty also needs to be considered. In ideal case, the duty cycle of the RT8280 can be calculated by below equation, But in practical case it will be higher than the calculation result since all the components in a converter circuit are not ideal. Figure 5 shows an example for the limit of maximum duty. With 5V input voltage, the 3.3V output voltage of the RT8280 becomes out of regulation when the output current is increased. However, when the input voltage is changed to 12V, the 3.3V output voltage of the RT8280 remains in regulation even with 3A output current. According to equation below, the duty cycle is 0.67 for the RT8280 operated with 5V input voltage and 3.3V output voltage in 2.2MHz switching frequency. The ideal case duty cycle calculation is already over the limit of maximum duty (65%). Thus, it is obvious that the RT8280 can't support 3A output current in such conditions :

$$\text{Duty Cycle} = 1 - 0.15 \times f_{SW} \quad (\text{MHz})$$

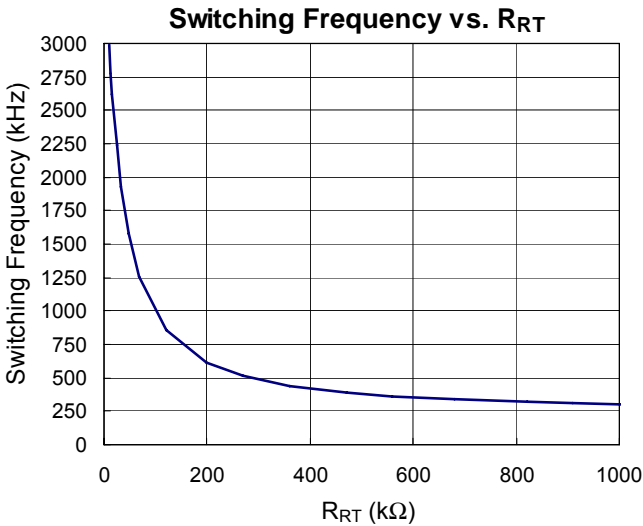

Figure 3. Switching Frequency vs. R_{RT}

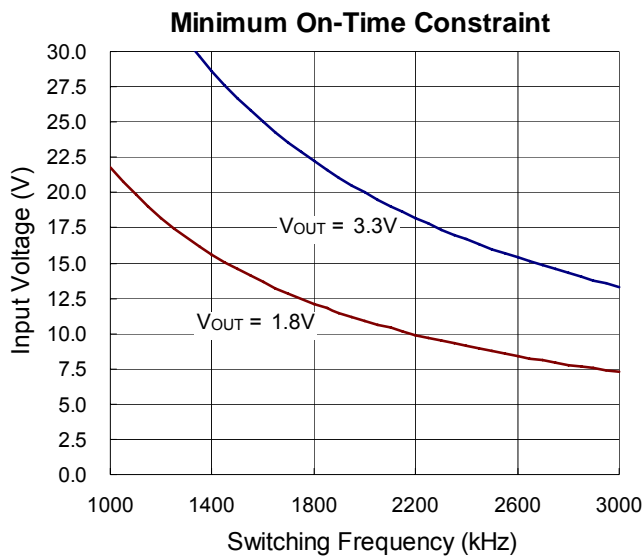

Figure 4. Minimum On-Time Constraint to Input Voltage

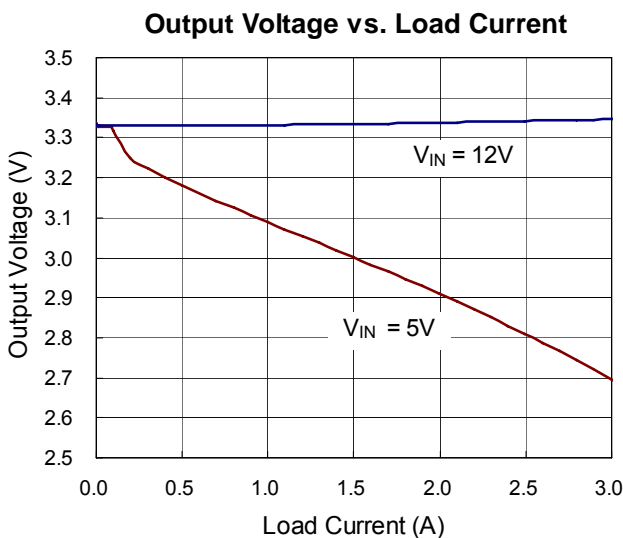

Figure 5. Limit of Maximum Duty

Chip Enable Operation

The EN pin is the enable input. Pull the EN pin low (<0.4V) to shutdown the device. During shutdown mode, the RT8280 quiescent current drops to lower than 25μA. Drive the EN pin high (>1.4V, < 5.5V), to turn on the device. If the EN pin is open, it will be pulled high by the internal circuit. For external timing control (e.g.RC), the EN pin can also be externally pulled high by adding a 100kΩ or greater resistor from the VIN pin (see Figure 6). In some cases, the output voltage of the RT8280 may still be under UVP threshold when soft-start finishes. Then the RT8280 will restart again and the output voltage of the RT8280 will rise to the regulation voltage. This phenomenon often happens in high frequency operation and with slow rising input voltage. It can easily be solved by adding a voltage divider on the EN pin. The RT8280 will be enabled when the input voltage rises close to the nominal input voltage.

Inductor Selection

The inductor value and operating frequency determine the ripple current according to a specific input and output voltage. The ripple current Δ_L increases with higher V_{IN} and decreases with higher inductance :

$$\Delta I_L = \left[\frac{V_{OUT}}{f_{SW} \times L} \right] \times \left[1 - \frac{V_{OUT}}{V_{IN}} \right]$$

Having a lower ripple current reduces not only the ESR losses in the output capacitors but also the output voltage ripple. Higher frequency combined with smaller ripple current is necessary to achieve high efficiency operation. However, it requires a large inductor to achieve this goal. For the ripple current selection, setting the maximum value of the ripple current Δ_L = 0.24(I_{MAX}) is a reasonable starting point. The largest ripple current occurs at the highest V_{IN}. To guarantee that the ripple current stays below the specified maximum, the inductor value should be chosen according to the following equation :

$$L = \left[\frac{V_{OUT}}{f_{SW} \times \Delta I_L(MAX)} \right] \times \left[1 - \frac{V_{OUT}}{V_{IN(MAX)}} \right]$$

The inductor's current rating (defined by that which causes a temperature rise from 25°C ambient to 40°C) should be greater than the maximum load current and its saturation current should be greater than the short circuit peak current limit. Refer to Table 2 for the suggested inductor selection.

Table2. Suggested Inductors for Typical Application Circuit

Component Supplier	Series	Dimensions (mm)
TDK	VLC6045	6 x 6 x 4.5
TDK	SLF12565	12.5 x 12.5 x 6.5
TAIYO YUDEN	NR8040	8 x 8 x 4

Diode Selection

When the power switch turns off, the path for the current is through the diode connected between the switch output and ground. This forward biased diode must have a minimal voltage drop and recovery time. Schottky diodes are recommended and should be able to handle those current. The reverse voltage rating of the diode should be greater than the maximum input voltage, and the current rating should be greater than the maximum load current. For details, please refer to Table 3.

Table 3. Suggested Diode

Component Supplier	Series	V _{RRM} (V)	I _{OUT} (A)	Package
DIODES	B330A	30	3	SMA
DIODES	B340A	40	3	SMA
PANJIT	SK33	30	3	DO-214AB
PANJIT	SK34	40	3	DO-214AB

C_{IN} and C_{OUT} Selection

The input capacitance, C_{IN}, is needed to filter the trapezoidal current at the source of the high side MOSFET. To prevent large ripple current, a low ESR input capacitor sized for the maximum RMS current should be used. The RMS current is given by :

$$I_{RMS} = I_{OUT(MAX)} \frac{V_{OUT}}{V_{IN}} \sqrt{\frac{V_{IN}}{V_{OUT}} - 1}$$

This formula has a maximum at V_{IN} = 2V_{OUT}, where I_{RMS} = I_{OUT} / 2. This simple worst-case condition is commonly used for design.

Choose a capacitor rated at a higher temperature than required. Several capacitors may also be paralleled to meet size or height requirements in the design.

For the input capacitor, one 10μF low ESR ceramic capacitors is recommended. For the recommended

capacitor, please refer to Table 4 below for more details.

The selection of C_{OUT} is determined by the required ESR to minimize voltage ripple.

Moreover, the amount of bulk capacitance is also a key for C_{OUT} selection to ensure that the control loop is stable. Loop stability can be checked by viewing the load transient response as described in a later section.

The output ripple, ΔV_{OUT}, is determined by :

$$\Delta V_{OUT} \leq \Delta I_L \left[ESR + \frac{1}{8fC_{OUT}} \right]$$

The output ripple will be highest at the maximum input voltage since ΔI_L increases with input voltage. Multiple capacitors placed in parallel may be needed to meet the ESR and RMS current handling requirement. Dry tantalum, special polymer, aluminum electrolytic and ceramic capacitors are all available in surface mount packages. Special polymer capacitors offer very low ESR value. However, it provides lower capacitance density than other types. Although Tantalum capacitors have the highest capacitance density, it is important to only use types that pass the surge test for use in switching power supplies. Aluminum electrolytic capacitors have significantly higher ESR. However, it can be used in cost sensitive applications for ripple current rating and long term reliability considerations. Ceramic capacitors have excellent low ESR characteristics but can have a high voltage coefficient and audible piezoelectric effects. The high Q of ceramic capacitors with trace inductance can also lead to significant ringing.

Nevertheless, high value low cost ceramic capacitors are now becoming available in smaller case sizes. Their high ripple current, high voltage rating and low ESR make them ideal for switching regulator applications. However, care must be taken when these capacitors are used at the input and output. When a ceramic capacitor is used at the input and the power is supplied by a wall adapter through long wires, a load step at the output can induce ringing at the input, V_{IN}. At best, this ringing can couple to the output and be mistaken as loop instability. At worst, a sudden inrush of current through the long wires can potentially cause a voltage spike at V_{IN} large enough to damage the part.

Checking Transient Response

The regulator loop response can be checked by looking at the load transient response. Switching regulators take several cycles to respond to a step in load current. When a load step occurs, V_{OUT} immediately shifts by an amount equal to $\Delta I_{LOAD} (ESR)$ and C_{OUT} also begins to be charged or discharged generating a feedback error signal for the regulator to return V_{OUT} to its steady state value. During this recovery time, V_{OUT} can be monitored for overshoot or ringing to indicate any stability problem.

Compensation Parameters

The switching frequency of the RT8280 can be programmed from free running frequency to 3MHz. Table 1 only lists the recommended compensation parameters for 2.2MHz switching frequency. Optimized compensation parameters for other switching frequency can also be determined through below procedures. The first step is to decide the crossover frequency, f_c . In general, the crossover frequency is one tenth of the switching frequency. Then, R_c can be obtained through the following equation :

$$R_C = \frac{2\pi \times C_{OUT} \times f_C \times V_{OUT}}{g_{CS} \times g_{EA} \times V_{FB}}$$

where

g_{CS} is Current Sense Transconductance = 1.8 (A/V)

g_{EA} is Error Amplifier Transconductance = 920 (μ A/V)

Once the value of R_c has been determined, the value of C_c can be obtained by the following equation :

$$C_C = \frac{1}{2\pi \times R_C \times \frac{f_C}{4}}$$

Choose a capacitor that is greater than the above calculation result. The frequency of the zero, which consists of R_C and C_C , should be lower than one fourth of f_C to get a sufficient phase margin. If the zero moves close to f_C , the phase margin decreases.

In some applications, the output capacitor will be an electrolytic capacitor, not a ceramic capacitor. A zero will be produced by the electrolytic capacitor and its ESR. C_P can be used to produce a pole with R_C to cancel the zero. To calculate C_P , follow the equation below :

$$C_P = \frac{C_{OUT} \times ESR}{R_C}$$

EMI Consideration

Since parasitic inductance and capacitance effects in PCB circuitry would cause a spike voltage on the SW pin when the high side MOSFET is turned-on/off, this spike voltage on SW may impact EMI performance in the system. In order to enhance EMI performance, there are two methods to suppress the spike voltage. One is to place an R-C snubber between SW and GND and place them as close as possible to the SW pin (see Figure 6). Another method is to add a resistor in series with the bootstrap capacitor, C_{BOOT} . But this method will decrease the driving capability to the high side MOSFET. It is strongly recommended to reserve the R-C snubber during PCB layout for EMI improvement. Moreover, reducing the SW trace area and keeping the main power in a small loop will be helpful for EMI performance. For detailed PCB layout guide, please refer to the section on Layout Consideration.

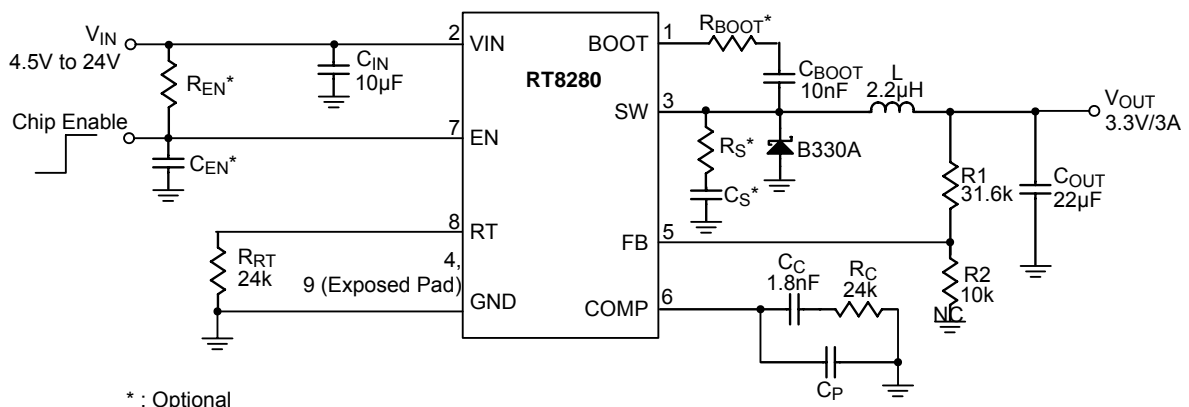

Figure 6. Reference Circuit with Snubber and Enable Timing Control

Thermal Considerations

For continuous operation, do not exceed absolute maximum junction temperature. The maximum power dissipation depends on the thermal resistance of the IC package, PCB layout, rate of surrounding airflow, and difference between junction and ambient temperature. The maximum power dissipation can be calculated by the following formula :

$$P_{D(MAX)} = (T_{J(MAX)} - T_A) / \theta_{JA}$$

where $T_{J(MAX)}$ is the maximum junction temperature, T_A is the ambient temperature, and θ_{JA} is the junction to ambient thermal resistance.

For recommended operating condition specifications, the maximum junction temperature is 125°C. The junction to ambient thermal resistance, θ_{JA} , is layout dependent. For SOP-8 (Exposed Pad) packages, the thermal resistance, θ_{JA} , is 75°C/W on a standard JEDEC 51-7 four-layer thermal test board. The maximum power dissipation at $T_A=25^\circ\text{C}$ can be calculated by the following formulas :

$$P_{D(MAX)} = (125^\circ\text{C} - 25^\circ\text{C}) / (75^\circ\text{C/W}) = 1.333\text{W}$$

(min. copper area PCB layout)

$$P_{D(MAX)} = (125^\circ\text{C} - 25^\circ\text{C}) / (49^\circ\text{C/W}) = 2.04\text{W}$$

(70mm² copper area PCB layout)

The thermal resistance, θ_{JA} , of SOP-8 (Exposed Pad) is determined by the package architectural design and the PCB layout design. The package architectural design is fixed. However, it's possible to increase thermal performance via better PCB layout copper design. The thermal resistance, θ_{JA} , can be decreased by adding copper area under the exposed pad of the SOP-8 (Exposed Pad) package.

As shown in Figure 7, the amount of copper area to which the SOP-8 (Exposed Pad) is mounted on affects thermal performance. When mounted to the standard SOP-8 (Exposed Pad) (Figure 7a), θ_{JA} is 75°C/W. Adding copper area under the SOP-8 (Exposed Pad) (Figure 7b) reduces θ_{JA} to 64°C/W. Further increasing the copper area to 70mm² (Figure 7e) will reduce θ_{JA} to 49°C/W.

The maximum power dissipation depends on operating ambient temperature for fixed $T_{J(MAX)}$ and thermal resistance, θ_{JA} . The derating curves in Figure 8 allow the

designer to see the effect of rising ambient temperature on the maximum power dissipation.

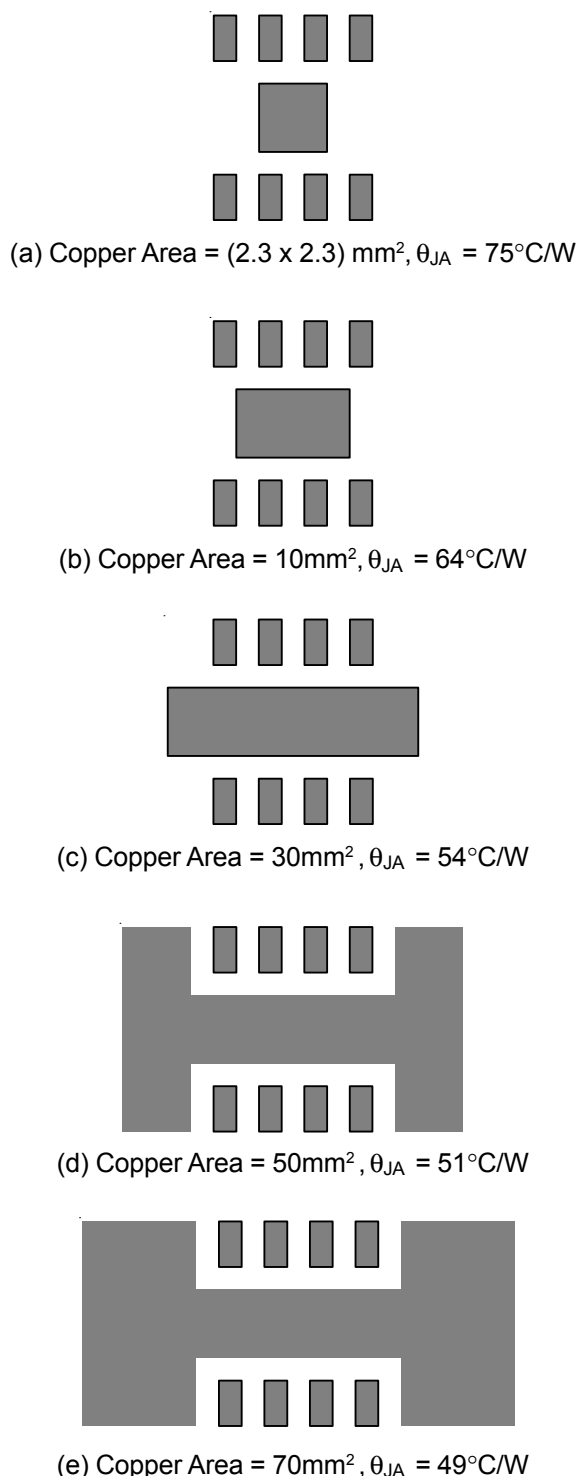

Figure 7. Thermal Resistance vs. Copper Area Layout Design

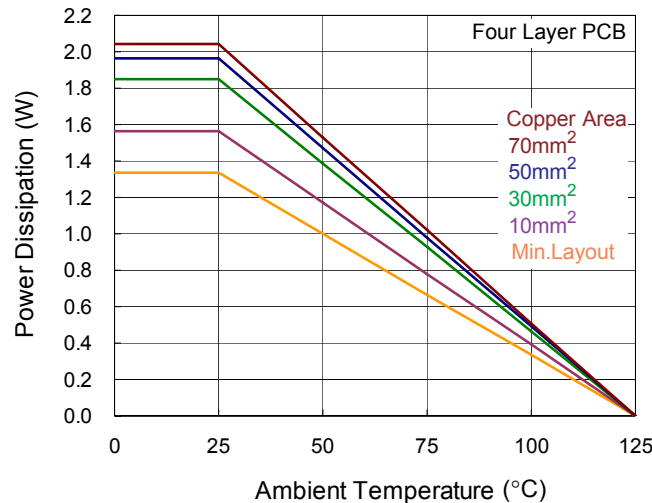

Figure 8. Derating Curves for RT8280 Package

Layout Consideration

Follow the PCB layout guidelines for optimum performance of the RT8280.

- ▶ Keep the traces of the main current paths as short and wide as possible.
- ▶ Place the input capacitor as close as possible to the device pins (VIN and GND).
- ▶ SW node experiences high frequency voltage swing and should be kept in a small area. Keep analog components away from the SW node to prevent stray capacitive noise pick up.

- ▶ Connect the feedback network behind the output capacitors. Keep the loop area small. Place the feedback components near the RT8280.
- ▶ Connect all analog grounds to a common node and then connect the common node to ground behind the output capacitors.
- ▶ An example of the PCB layout guide is shown in Figure 9 for reference.

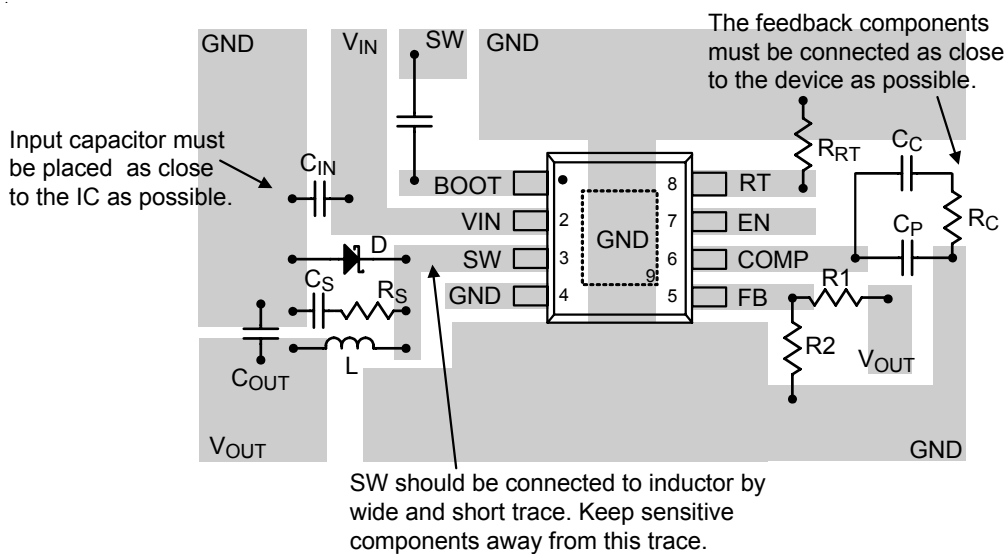
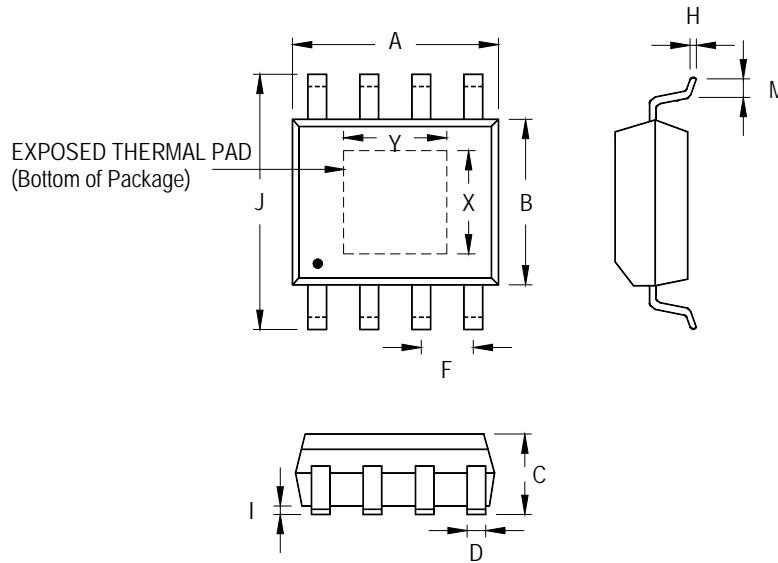

Figure 9. PCB Layout Guide

Table 4. Suggested Capacitors for C_{IN} and C_{OUT}

Location	Component Supplier	Part No.	Capacitance (μF)	Case Size
C _{IN}	MURATA	GRM31CR61E106K	10	1206
C _{IN}	TDK	C3225X5R1E106K	10	1206
C _{IN}	TAIYO YUDEN	TMK316BJ106ML	10	1206
C _{OUT}	MURATA	GRM31CR60J476M	47	1206
C _{OUT}	TDK	C3225X5R0J476M	47	1210
C _{OUT}	MURATA	GRM32ER71C226M	22	1210
C _{OUT}	TDK	C3225X5R1C226M	22	1210

Outline Dimension



Symbol	Dimensions In Millimeters		Dimensions In Inches		
	Min	Max	Min	Max	
A	4.801	5.004	0.189	0.197	
B	3.810	4.000	0.150	0.157	
C	1.346	1.753	0.053	0.069	
D	0.330	0.510	0.013	0.020	
F	1.194	1.346	0.047	0.053	
H	0.170	0.254	0.007	0.010	
I	0.000	0.152	0.000	0.006	
J	5.791	6.200	0.228	0.244	
M	0.406	1.270	0.016	0.050	
Option 1	X	2.000	2.300	0.079	0.091
	Y	2.000	2.300	0.079	0.091
Option 2	X	2.100	2.500	0.083	0.098
	Y	3.000	3.500	0.118	0.138

8-Lead SOP (Exposed Pad) Plastic Package

Richtek Technology Corporation

5F, No. 20, Taiyuen Street, Chupei City
 Hsinchu, Taiwan, R.O.C.
 Tel: (8863)5526789

Richtek products are sold by description only. Richtek reserves the right to change the circuitry and/or specifications without notice at any time. Customers should obtain the latest relevant information and data sheets before placing orders and should verify that such information is current and complete. Richtek cannot assume responsibility for use of any circuitry other than circuitry entirely embodied in a Richtek product. Information furnished by Richtek is believed to be accurate and reliable. However, no responsibility is assumed by Richtek or its subsidiaries for its use; nor for any infringements of patents or other rights of third parties which may result from its use. No license is granted by implication or otherwise under any patent or patent rights of Richtek or its subsidiaries.