

Specify AEL

Plastic Moulded Crystal SXA/86SMX & CM309S

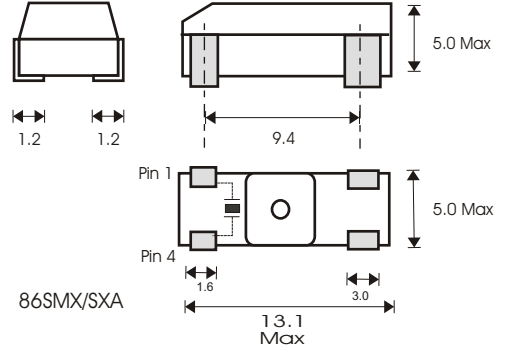

Surface Mounted Quartz Crystal Resonators

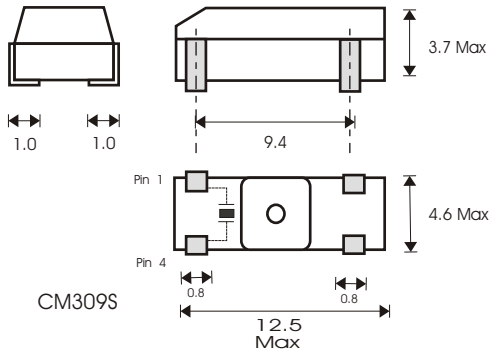

FEATURES

- Standard Frequencies Ex-Stock
- Suitable for Reflow Soldering
- Standard I.C Height
- Designed for High Density PCB

APPLICATIONS

- Microprocessor Systems
- Datacommunications
- Consumer Electronics
- Automotive Electronics

STANDARD SPECIFICATION

Frequency Range:	3.20 MHz to 90.00 MHz
Adjustment Tolerance at 25°C:	30PPM Max.
Frequency Stability:	50PPM Max.
Operating Temperature Range:	-10°C to +60°C
Load Capacity:	30pF
E.S.R.:	See Table
Drive level:	50~100 MicroWatt
Ageing:	5PPM 1st Year Max.

Frequency Range	E.S.R	Mode
3.5 MHz ~ 3.99 MHz	200	Fund
4.0 MHz ~ 4.49 MHz	150	Fund
4.5 MHz ~ 4.99 MHz	120	Fund
5.0 MHz ~ 5.99 MHz	100	Fund
6.0 MHz ~ 8.99 MHz	80	Fund
9.0 MHz ~ 9.99 MHz	60	Fund
10.0 MHz ~ 12.99 MHz	50	Fund
13.0 MHz ~ 18.99 MHz	35	Fund
19.0 MHz ~ 29.99 MHz	25	Fund
30.0 MHz ~ 33.99 MHz	20	Fund
30.0 MHz ~ 34.99 MHz	80	3 O/T
35.0 MHz ~ 39.99 MHz	70	3 O/T
40.0 MHz ~ 44.99 MHz	65	3 O/T
45.0 MHz ~ 49.99 MHz	60	3 O/T
50.0 MHz ~ 90.00 MHz	80	3 O/T

AVAILABLE OPTIONS

Frequency Range:	3.2 MHz ~ 90.0 MHz
Adjustment Tolerance	15PPM ~ 100PPM
Op. Temp. Range:	-40°C to +85°C
Load Capacity:	Series or 9pF ~ 50pF
Tape & Reel:	1,000pcs/Reel

Suggested Solder Pad Layout

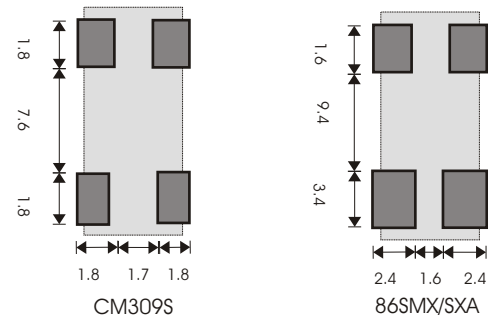

Solder Conditions

Hand Solder	280°C ~ 350°C 3 Secs
Solder Dip	240°C 5 Secs Max
Reflow Soldering	140°C (10°C) 100 Secs Max
PreHeat	
Reflow	Over 200°C 25 Secs Max 230°C 5°C 5 Secs Max



www.aelcrystals.co.uk

quartz based frequency control components

Order Hotline +44 1293 524245

www.aelcrystals.co.uk
sales@aelcrystals.co.uk