

FEATURES

- ✧ Low Power consumption
- ✧ High slew rate
- ✧ Low distortion
- ✧ Large output swing
- ✧ Low standby current
- ✧ Excellent power supply ripple rejection
- ✧ Wide temperature operation
- ✧ No switch ON/OFF click noise

DESCRIPTION

The TP5218 is Class AB stereo headphone amplifier, , It have SOP8 and DIP8 package. The chip is high performance design by 0.5 μ m CMOS process and low pin count low cost device, Otherwise, the TP5218 have high impedance amplifier and have low noise design.

Applications

- ✧ Headphone drive
- ✧ CD_ROM stereo driver
- ✧ MP3 walkman audio driver
- ✧ Portable audio
- ✧ Hi-Fi audio system

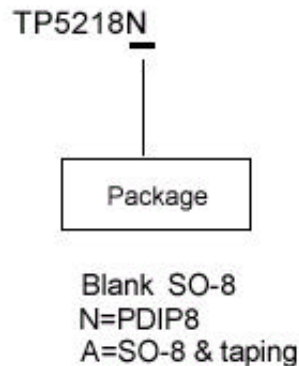
ORDERING INFORMATION

* All specs and applications shown above subject to change without prior notice.

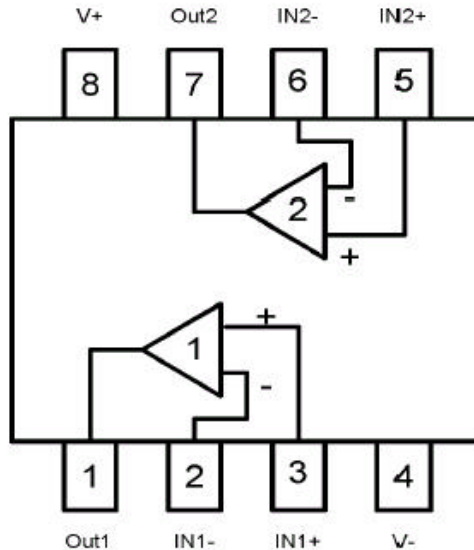
Block Diagram

Electrical Character

Vdd=5;Temp=25 ;Fin=1KHz;RL=32 ;Vin=1.4V;

Symbol	Parameter	Condition	Min	Typ	Max	Unit
VDD		Single power	2.4	5	7	V
		Dual power	1.2	2.5	3.5	
VSS		Dual power	-1.2	-2.5	-3.5	V
IDD		No load		2.2	3.5	mA
Ptotal	Total consumption power	No load		11		mW
Vo	Output swing	RL=5K		3 4.9		V
Io	Output current			60		mA

Continue to next page

* All specs and applications shown above subject to change without prior notice.

Symbol	Parameter	Condition	Min	Typ	Max	Unit
Po	Output power			60		mW
PSRR	Power supply ripple rejection	Fin=60Hz; V _{ripple} =100mV		71.8		dB
ts	Channel isolation	Amp A in Amp B out		100		dB
		Amp B in Amp A out		110		
Ro	Output resistance			3		
THD	Total harmonic distortion	Vo=3		0.05		%
		Vo=3 RL=5K		0.007		
Vin max		THD < 0.1%		1.1		V
SNR	Signal to Noise		100			dB
Tamb	Operation ambient temperature		-40		70	
			-40		158	
Tsot	Storage temperature		-60		160	
			-76		320	
V _{MAX}	Max/Min voltage	RL=32 Vin=2V *1 Vo=4Vpp	1.9		12	V

*1 Note 1: This is voltage only for test, it will cause chipw temperature up to 67 , We not recommend TP5218 operating in this voltage.

* All specs and applications shown above subject to change without prior notice.

Electrical Character

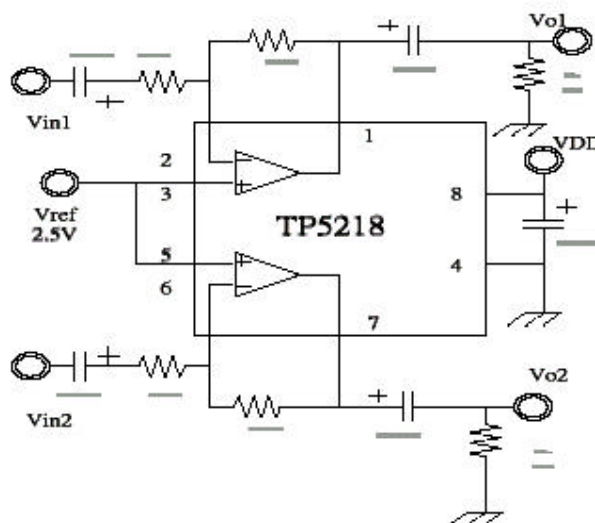

Frequency Response

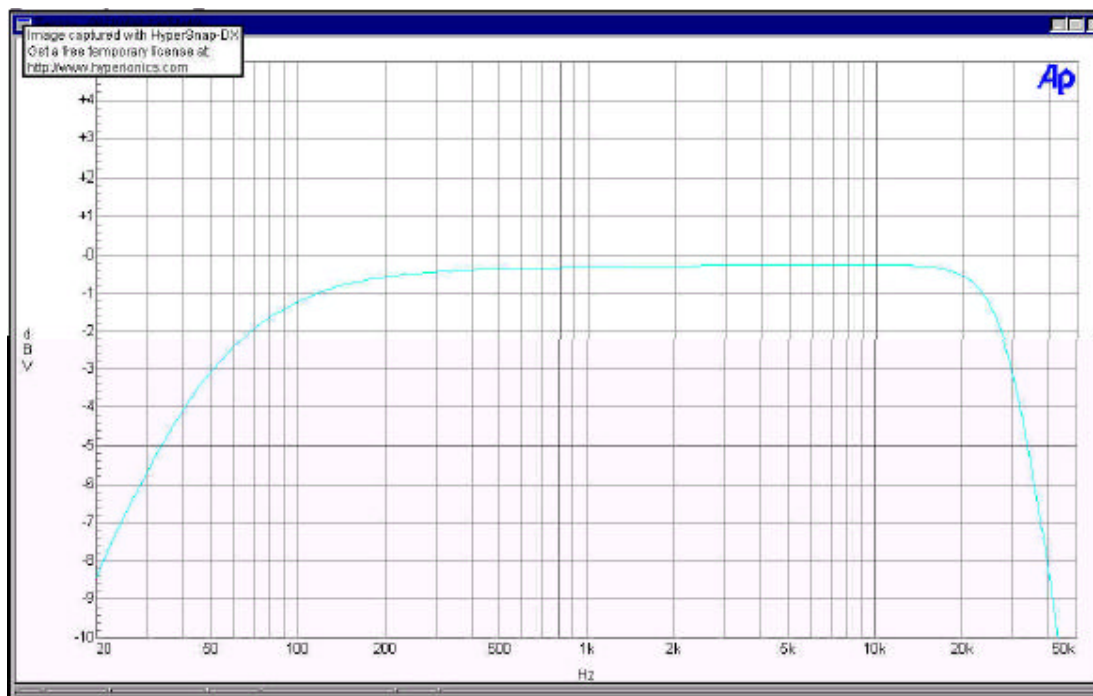

* All specs and applications shown above subject to change without prior notice.

1F-5 NO.66 SEC.2 NAN-KAN RD., LUCHU, TAOYUAN, TAIWAN, R.O.C

Tel:886-3-3529445

Fax:886-3-3521052

Email: server@ceramate.com.tw

Http: www.ceramate.com.tw

Rev 1.1 Dec 26,2001

Package SOP8

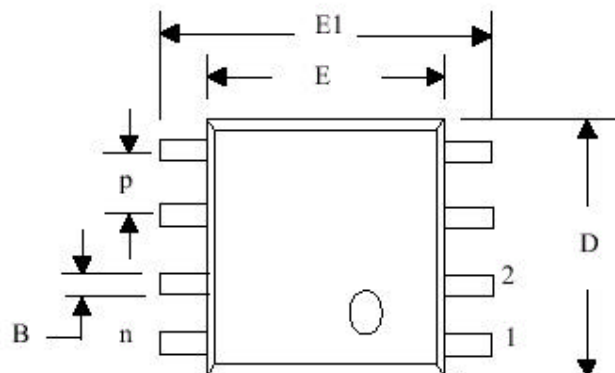

Units		INCHES			MILLIMETERS		
Dimension Limits		MIN	NOM	MAX	MIN	NOM	MAX
Pitch	P		0.050			1.27	
Number of Pins	N		8			8	
Molded Package Length	D	0.189	0.193	0.196	4.80	4.89	4.98
Molded Package Width	E	0.150	0.154	0.157	3.81	3.90	3.99
Outside Dimension	E1	0.229	0.237	0.244	5.82	6.01	6.20
Lower Lead Width	B	0.014	0.017	0.020	0.36	0.43	0.51

PCB Demo Board

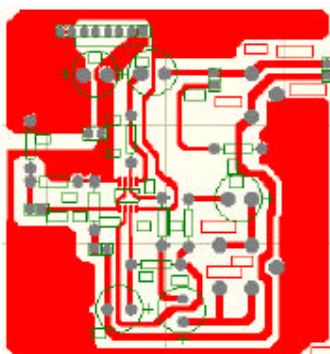

* All specs and applications shown above subject to change without prior notice.

1F-5 NO.66 SEC.2 NAN-KAN RD., LUCHU, TAOYUAN, TAIWAN, R.O.C

Tel:886-3-3529445

Fax:886-3-3521052

Email: server@ceramate.com.tw

Http: www.ceramate.com.tw

Rev 1.1 Dec 26,2001