



## P-CHANNEL ENHANCEMENT MODE POWER MOSFET

### DESCRIPTION

The UTC **UT9564** is a P-ch enhancement mode power MOSFET and it uses UTC perfect technology to provide customers with fast switching, ruggedized device design, low on-resistance and cost-effectiveness.

The UTC **UT9564** is ideal for applications such as low voltage applications, DC/DC converters and all commercial-industrial surface mount applications.

### FEATURES

- \* Simple Drive Requirement
- \* Fast Switching Speed
- \* Low On-Resistance

### SYMBOL

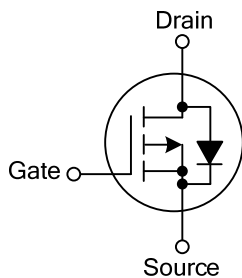

### ORDERING INFORMATION

Ordering Number		Package	Pin Assignment								Packing
Lead Free	Halogen Free		1	2	3	4	5	6	7	8	
UT9564L-TN3-R	UT9564G-TN3-R	TO-252	G	D	S	-	-	-	-	-	Tape Reel
UT9564L-S08-R	UT9564G-S08-R	SOP-8	S	S	S	G	D	D	D	D	Tape Reel
UT9564L-S08-T	UT9564G-S08-T	SOP-8	S	S	S	G	D	D	D	D	Tube

<p>UT9564L-S08-R</p> <p>(1)Packing Type</p> <p>(2)Package Type</p> <p>(3)Halogen Free</p>	<p>(1) R: Tape Reel, T: Tube</p> <p>(2) S08: SOP-8, TN3: TO-252</p> <p>(3) G: Halogen Free, L: Lead Free</p>
---	--

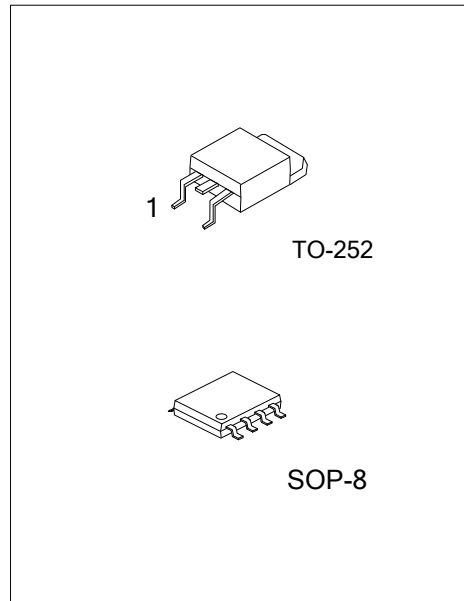

■ PIN CONFIGURATION

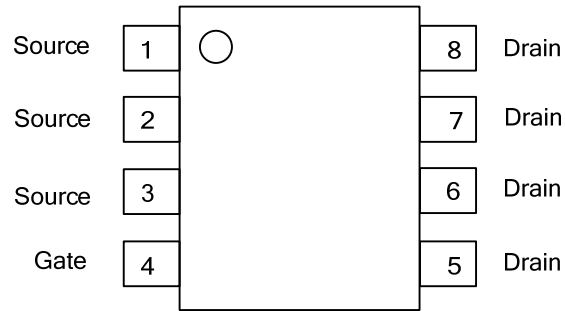

### ■ ABSOLUTE MAXIMUM RATINGS

PARAMETER	SYMBOL	RATINGS	UNIT	
Drain-Source Voltage	$V_{DS}$	-40	V	
Gate-Source Voltage	$V_{GS}$	$\pm 25$	V	
Continuous Drain Current (Note 2)	$I_D$	$T_A=25^\circ\text{C}$	-7.3	A
		$T_A=70^\circ\text{C}$	-5.9	A
Pulsed Drain Current (Note 1)	$I_{DM}$	-30	A	
Power Dissipation ( $T_A=25^\circ\text{C}$ )	$P_D$	TO-252	2	W
		SOP-8	2.5	
Linear Derating Factor		0.02	W/ $^\circ\text{C}$	
Junction Temperature	$T_J$	-55 ~ 150	$^\circ\text{C}$	
Storage Temperature	$T_{STG}$	-55 ~ 150	$^\circ\text{C}$	

Note: Absolute maximum ratings are those values beyond which the device could be permanently damaged.

Absolute maximum ratings are stress ratings only and functional device operation is not implied.

### ■ THERMAL DATA

PARAMETER	SYMBOL	RATINGS	UNIT	
Junction to Ambient (Note 2)	$\theta_{JA}$	TO-252	62.5	$^\circ\text{C}/\text{W}$
		SOP-8	50	

Note: 1. Pulse width limited by Max. junction temperature.

2. Surface mounted on 1 in<sup>2</sup> copper pad of FR4 board,  $t \leq 10\text{sec}$ ; 125 $^\circ\text{C}/\text{W}$  when mounted on Min. copper pad.

### ■ ELECTRICAL CHARACTERISTICS ( $T_J=25^\circ\text{C}$ , unless otherwise specified)

PARAMETER	SYMBOL	TEST CONDITIONS	MIN	TYP	MAX	UNIT	
<b>OFF CHARACTERISTICS</b>							
Drain-Source Breakdown Voltage	$BV_{DSS}$	$I_D=-250\mu\text{A}$ , $V_{GS}=0\text{V}$	-40			V	
Breakdown Voltage Temperature Coefficient	$\Delta BV_{DSS}/\Delta T_J$	Reference to 25 $^\circ\text{C}$ , $I_D=-1\text{mA}$		-0.03		V/ $^\circ\text{C}$	
Drain-Source Leakage Current	$I_{DSS}$	$V_{DS}=-40\text{V}$ , $V_{GS}=0\text{V}$ , $T_J=25^\circ\text{C}$			-1	$\mu\text{A}$	
		$V_{DS}=-32\text{V}$ , $V_{GS}=0\text{V}$ , $T_J=70^\circ\text{C}$			-25		
Gate- Source Leakage Current	$I_{GSS}$	$V_{GS}=\pm 25\text{V}$			$\pm 100$	nA	
<b>ON CHARACTERISTICS</b>							
Gate Threshold Voltage	$V_{GS(TH)}$	$V_{DS}=V_{GS}$ , $I_D=-250\mu\text{A}$	-1		-3	V	
Static Drain-Source On-State Resistance (Note)	$R_{DS(ON)}$	$V_{GS}=-10\text{V}$ , $I_D=-7\text{A}$			28	m $\Omega$	
		$V_{GS}=-4.5\text{V}$ , $I_D=-5\text{A}$			40		
Forward Transconductance	$g_{FS}$	$V_{DS}=-10\text{V}$ , $I_D=-7\text{A}$		13		S	
<b>DYNAMIC PARAMETERS</b>							
Input Capacitance	$C_{ISS}$	$V_{GS}=0\text{V}$ , $V_{DS}=-25\text{V}$ , $f=1.0\text{MHz}$		2240	3600	pF	
Output Capacitance	$C_{OSS}$			300			pF
Reverse Transfer Capacitance	$C_{RSS}$			250			pF
<b>SWITCHING PARAMETERS</b>							
Total Gate Charge (Note)	$Q_G$	$V_{GS}=-4.5\text{V}$ , $V_{DS}=-32\text{V}$ , $I_D=-7\text{A}$		27	43	nC	
Gate to Source Charge	$Q_{GS}$			6			nC
Gate to Drain Charge	$Q_{GD}$			14			nC
Turn-ON Delay Time (Note)	$t_{D(ON)}$	$V_{GS}=-10\text{V}$ , $V_{DS}=-20\text{V}$ , $I_D=-1\text{A}$ , $R_G=3.3\Omega$ , $R_D=20\Omega$		14		ns	
Rise Time	$t_R$			8			ns
Turn-OFF Delay Time	$t_{D(OFF)}$			46			ns
Fall-Time	$t_F$			17			ns
<b>SOURCE- DRAIN DIODE RATINGS AND CHARACTERISTICS</b>							
Drain-Source Diode Forward Voltage (Note)	$V_{SD}$	$I_S=-2\text{A}$ , $V_{GS}=0\text{V}$			-1.2	V	
Reverse Recovery Time (Note)	$t_{RR}$	$I_S=-7\text{A}$ , $V_{GS}=0\text{V}$ ,		37		ns	
Reverse Recovery Charge	$Q_{RR}$	$dI/dt=100\text{A}/\mu\text{s}$		57		nC	

Note: Pulse width  $\leq 300\mu\text{s}$ , duty cycle  $\leq 2\%$ .

UTC assumes no responsibility for equipment failures that result from using products at values that exceed, even momentarily, rated values (such as maximum ratings, operating condition ranges, or other parameters) listed in products specifications of any and all UTC products described or contained herein. UTC products are not designed for use in life support appliances, devices or systems where malfunction of these products can be reasonably expected to result in personal injury. Reproduction in whole or in part is prohibited without the prior written consent of the copyright owner. The information presented in this document does not form part of any quotation or contract, is believed to be accurate and reliable and may be changed without notice.