

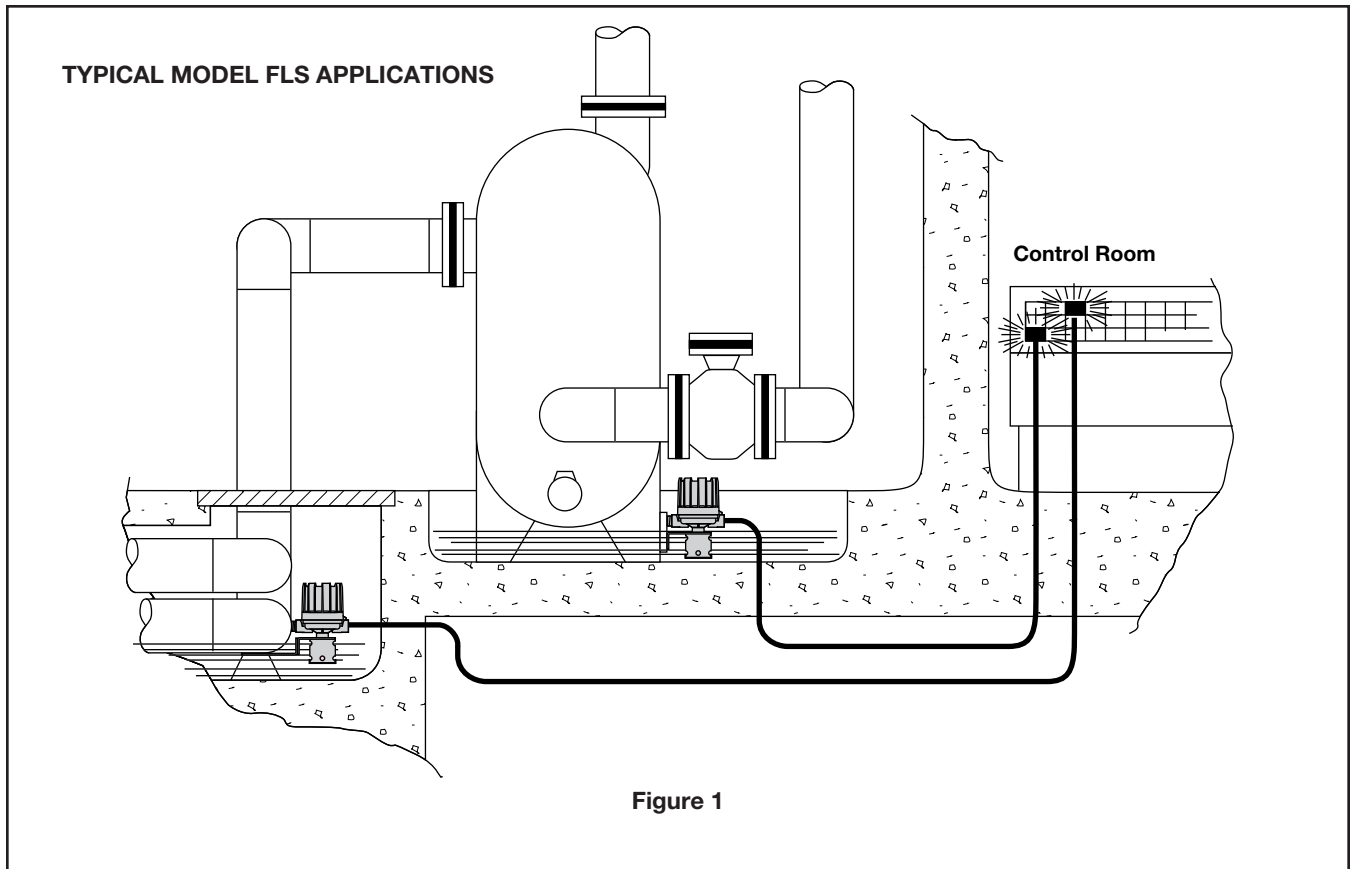

Model FLS Flood Level Switch Descriptive Data



DESCRIPTION

The Model FLS, part number 53-4701-001, is a float operated, liquid level control designed for bracket mounting in floor level sumps or troughs. The proven Magnetrol magnetic coupling is employed to transmit float movement to a single snap-action dry contact switch mechanism. The switch is factory set for $\frac{3}{4}$ " level differential for off-on control—alarm and/or safety shutdown service.

APPLICATIONS

The Model FLS is used to detect leaks or spills from critical valves, vessels, and pipelines in power plant installations, as shown in Figure 1.

CONSTRUCTION

Simple and rugged in design, the Model FLS is constructed of quality materials throughout to assure reliable operation and a long trouble-free service life.

FLOAT ENVELOPE

A perforated stainless steel float envelope is welded to a forged steel bracket assembly totally enclosing the float and providing a side mounting surface. A stainless steel bottom strap, tack welded to the float envelope, acts as a low level float stop.

FLOAT AND TRIM

300 series stainless steel float with a 400 series magnetic attraction sleeve. Internal trim is 300 series stainless steel.

SWITCH MECHANISM

The Magnetrol series B switch mechanism with SPDT contacts is standard and rated:

15 A resistive & 3.8 A inductive @ 120 VAC
0.50 A resistive & 0.05 A inductive @ 120 VDC
180°F maximum ambient temperature

SWITCH HOUSING

A NEMA 4X,6,7/9 cast aluminum submersible electrical enclosure is standard, and allows 180° positioning of the conduit outlet for wiring convenience.

AVAILABLE OPTION

Qualified to IEEE 323-1974, and IEEE 344-1975.

DIMENSIONAL SPECIFICATIONS inches (mm)

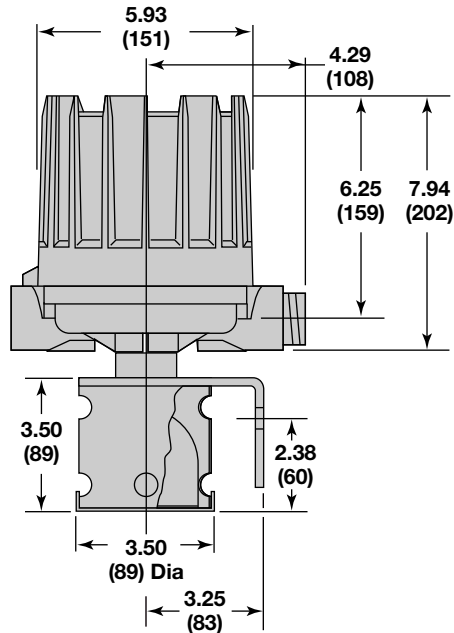

5300 Belmont Road • Downers Grove, Illinois 60515-4499 • 630-969-4000 • Fax 630-969-9489 • www.magnetrol.com
145 Jardin Drive, Units 1 & 2 • Concord, Ontario Canada L4K 1X7 • 905-738-9600 • Fax 905-738-1306
Heikensstraat 6 • B 9240 Zele, Belgium • 052 45.11.11 • Fax 052 45.09.93
Regent Business Ctr., Jubilee Rd. • Burgess Hill, Sussex RH15 9TL U.K. • 01444-871313 • Fax 01444-871317



5300 Belmont Road • Downers Grove, Illinois 60515-4499 • 630-969-4028 • Fax 630-969-9489 • www.sticontrols.com

Copyright © 2008 Magnetrol International, Incorporated. All rights reserved. Printed in the USA.

BULLETIN: 44-306.6
EFFECTIVE: September 2000
SUPERSEDES: October 1995