



- Simple Matching to 50 ohms
- 5.0 X 7.0 mm Surface-mount Case
- Complies with Directive 2002/95/EC (RoHS)



**SF2141B**

**210.38 MHz  
SAW Filter**

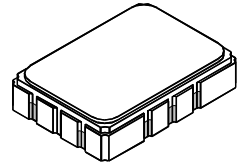

**SMP-03**

**Absolute Maximum Ratings**

Rating	Value	Units
Input Power Level	+10	dBm
DC Voltage on any Non-ground Terminal	3	V
Storage Temperature Range in Tape and Reel	-40 to +85	°C
Maximum Soldering Temperature	265 °C for 10 s	

**Electrical Characteristics**

Characteristic	Sym	Notes	Min	Typ	Max	Units
Center Frequency	$f_C$	1	210.38			MHz
Insertion Loss at $f_C$	IL			8.2	11	dB
Amplitude Ripple, $f_C \pm 0.30$ MHz	AR	1		0.4	1.3	dB <sub>P-P</sub>
Group Delay				716		ns
Group Delay Ripple, $f_C \pm 0.30$ MHz				150		ns <sub>P-P</sub>
Phase Linearity, $f_C \pm 0.63$ MHz	RMS			2.60	3.75	deg
5 dB Bandwidth			$\pm 0.63$	$\pm 0.82$		MHz
34 dB Bandwidth				$\pm 1.18$	$\pm 1.25$	
36 dB Bandwidth				$\pm 1.20$	$\pm 1.55$	
Attenuation Referenced to IL:						
$f_C \pm 1.25$ MHz			35	48		dB
140 to 206 MHz			38	45		
214.76 to 280.00 MHz			38	48		
Operating Temperature Range	$T_A$	1	-25		+85	°C
Case Style		5	SMP-03 7 x 5 mm Nominal Footprint			
Lid Symbolization (YY=year, WW=week, S=shift) See note 4			RFM SF2141B YYWWS##			



**CAUTION: Electrostatic Sensitive Device. Observe precautions for handling.**

**Notes:**

1. Unless noted otherwise, all specifications apply over the operating temperature range with filter soldered to the specified demonstration board with impedance matching to 50  $\Omega$  and measured with 50  $\Omega$  network analyzer.
2. Unless noted otherwise, all frequency specifications are referenced to the nominal center frequency,  $f_C$ .
3. Rejection is measured as attenuation below the minimum IL point in the passband. Rejection in final user application is dependent on PCB layout and external impedance matching design. See Application Note No. 42 for details.
4. The design, manufacturing process, and specifications of this filter are subject to change.
5. Tape and Reel Standard Per ANSI / EIA 481.
6. Either Port 1 or Port 2 may be used for either input or output in the design. However, impedances and impedance matching may vary between Port 1 and Port 2, so that the filter must always be installed in one direction per the circuit design.
7. US and international patents may apply.
8. RFM, stylized RFM logo, and RF Monolithics, Inc. are registered trademarks of RF Monolithics, Inc.

## Single-ended 50 ohm input / output test circuit

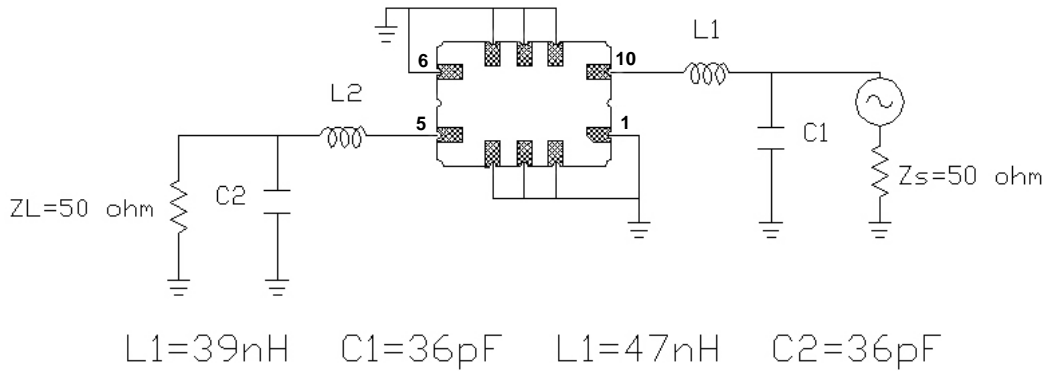

## Single-ended 50 ohm input / 500 ohm balanced output test circuit

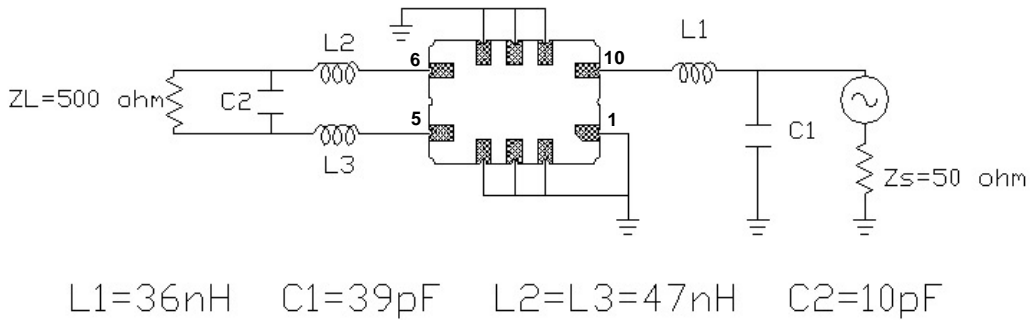

## Filter Broadband Amplitude Response

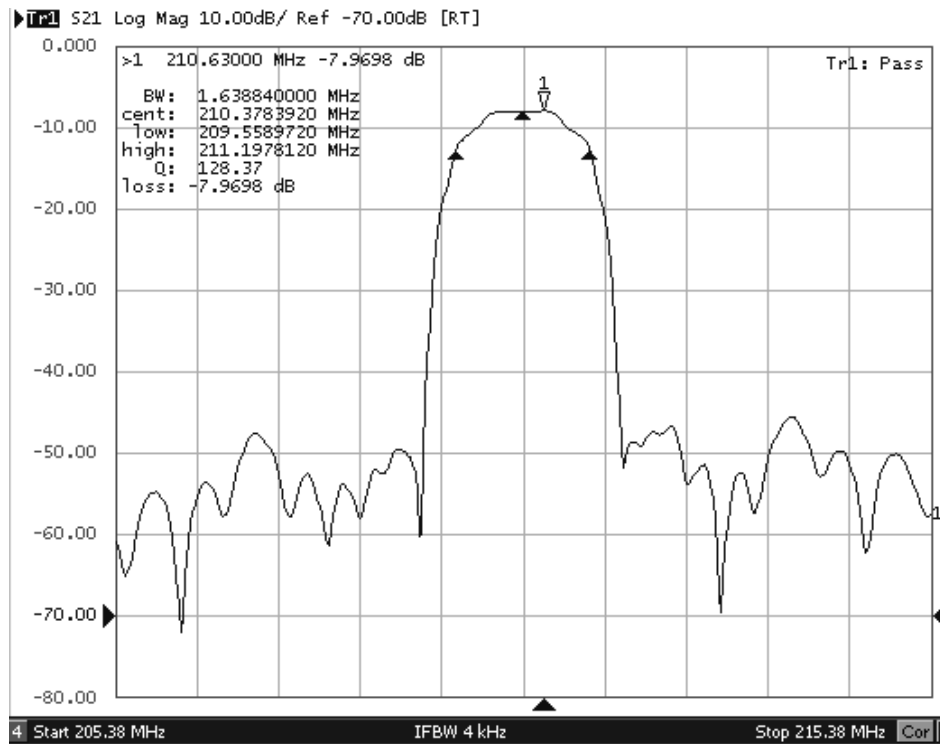

## Filter Passband Amplitude Response

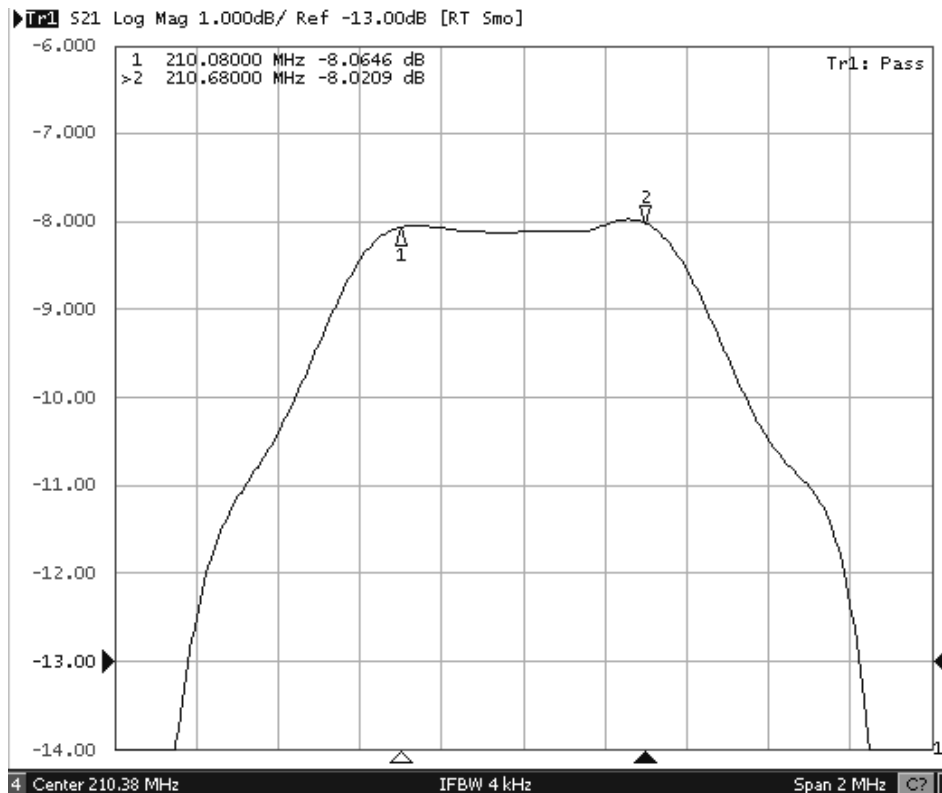

## Filter Passband Group Delay

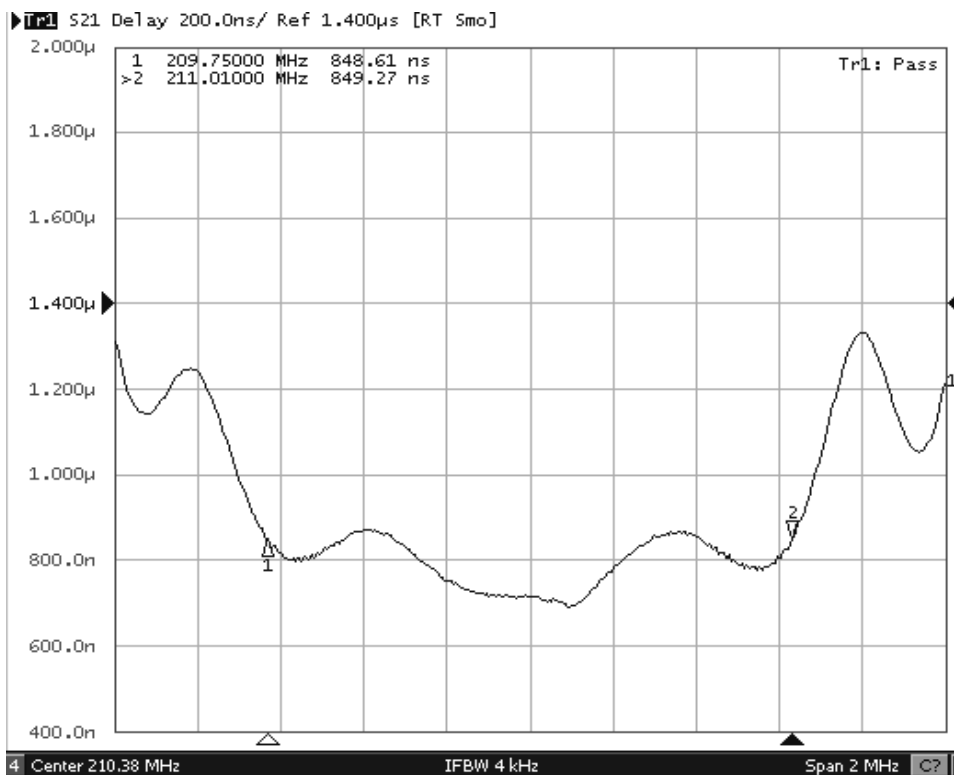

# SMP-03 Case

## 10-Terminal Ceramic Surface-mount Case

### 7 x 5 mm Nominal Footprint

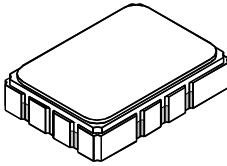

Recommended PCB Footprint

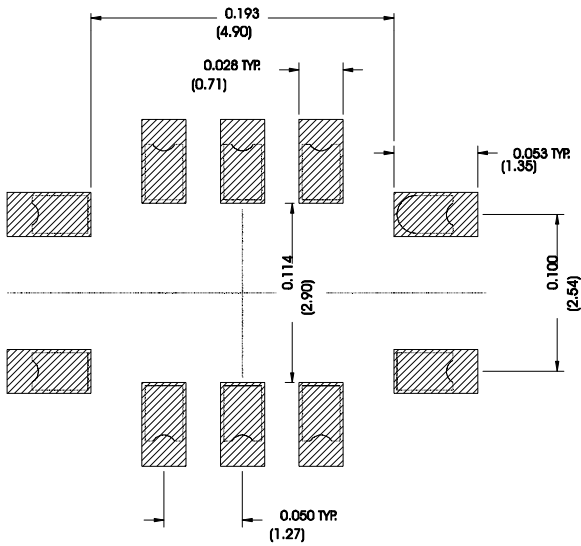

Case Dimensions						
Dimension	mm			Inches		
	Min	Nom	Max	Min	Nom	Max
A	6.80	7.00	7.20	0.268	0.276	0.283
B	4.80	5.00	5.20	0.189	0.197	0.205
C		1.65	2.00		0.065	0.079
D	.47	0.60	.73	0.019	0.024	0.029
E	2.41	2.54	2.67	0.095	0.100	0.105
H	0.87	1.0	1.13	0.034	0.039	0.044
J	4.87	5.00	5.13	0.192	0.197	0.202
K	2.87	3.00	3.13	0.113	0.118	0.123
P	1.14	1.27	1.40	0.045	0.050	0.055

Electrical Connections	
Connection	Terminals
Input	1
Input Ground	10
Output	6
Output Ground	5
Ground	All others

Case	
Materials	
Solder Pad Plating	0.3 to 1.0 $\mu\text{m}$ Gold over 1.27 to 8.89 $\mu\text{m}$ Nickel
Lid Plating	2.0 to 3.0 $\mu\text{m}$ Nickel
Body	$\text{Al}_2\text{O}_3$ Ceramic
	Pb Free

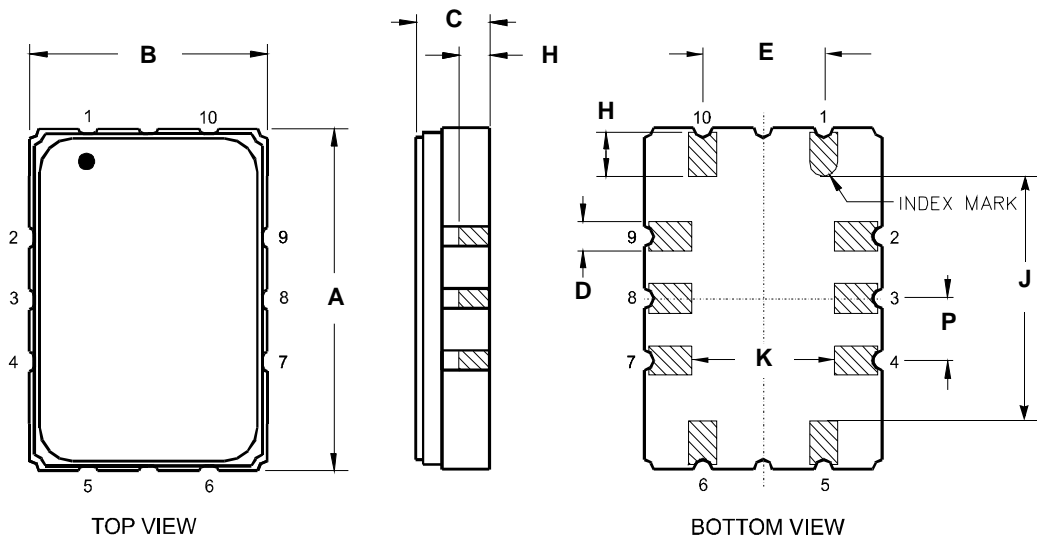

## Tape and Reel Specifications

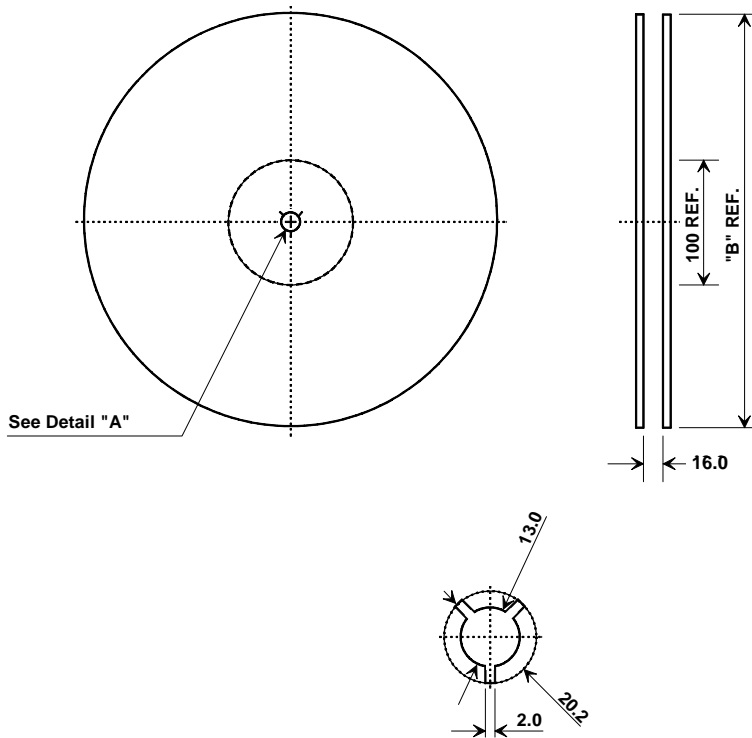

"B"		Quantity Per Reel
Inches	millimeters	
7	178	500
13	330	2000

## COMPONENT ORIENTATION and DIMENSIONS

Carrier Tape Dimensions	
Ao	5.5 mm
Bo	7.5 mm
Ko	2.0 mm
Pitch	8.0 mm
W	16.0 mm

