



## VTM™ Transformer



### FEATURES

- 40 Vdc to 1 Vdc 130 A transformer
  - Operating from standard 48 V or 24 V PRM™ regulators
- High efficiency (>94%) reduces system power consumption
- High density (443 A/in<sup>3</sup>)
- “Full Chip” V•I Chip package enables surface mount, low impedance interconnect to system board
- Contains built-in protection features:
  - Overvoltage Lockout
  - Overcurrent
  - Short Circuit
  - Overtemperature
- Provides enable / disable control, internal temperature monitoring
- ZVS / ZCS resonant Sine Amplitude Converter topology
- Less than 50°C temperature rise at full load in typical applications

### DESCRIPTION

The V•I Chip™ transformer is a high efficiency (>94%) Sine Amplitude Converter™ (SAC™) operating from a 26 to 55 Vdc primary bus to deliver an isolated output. The Sine Amplitude Converter offers a low AC impedance beyond the bandwidth of most downstream regulators; therefore capacitance normally at the load can be located at the input to the Sine Amplitude Converter. Since the K factor of the VTM48EF012T130A00 is 1/40, the capacitance value can be reduced by a factor of 1600, resulting in savings of board area, materials and total system cost.

The VTM48EF012T130A00 is provided in a V•I Chip package compatible with standard pick-and-place and surface mount assembly processes. The co-molded V•I Chip package provides enhanced thermal management due to a large thermal interface area and superior thermal conductivity. The high conversion efficiency of the VTM48EF012T130A00 increases overall system efficiency and lowers operating costs compared to conventional approaches.

The VTM48EF012T130A00 enables the utilization of Factorized Power Architecture™ which provides efficiency and size benefits by lowering conversion and distribution losses and promoting high density point of load conversion.

### TYPICAL APPLICATIONS

- High End Computing Systems
- Automated Test Equipment
- High Density Power Supplies
- Communications Systems

$V_{IN} = 26 \text{ to } 55 \text{ V}$	$I_{OUT} = 130 \text{ A}_{(NOM)}$
$V_{OUT} = 0.7 \text{ to } 1.4 \text{ V}_{(NO \text{ LOAD})}$	$K = 1/40$

PART NUMBER	DESCRIPTION
VTM48EF012T130A00	-40°C to 125°C T <sub>J</sub>

### TYPICAL APPLICATION

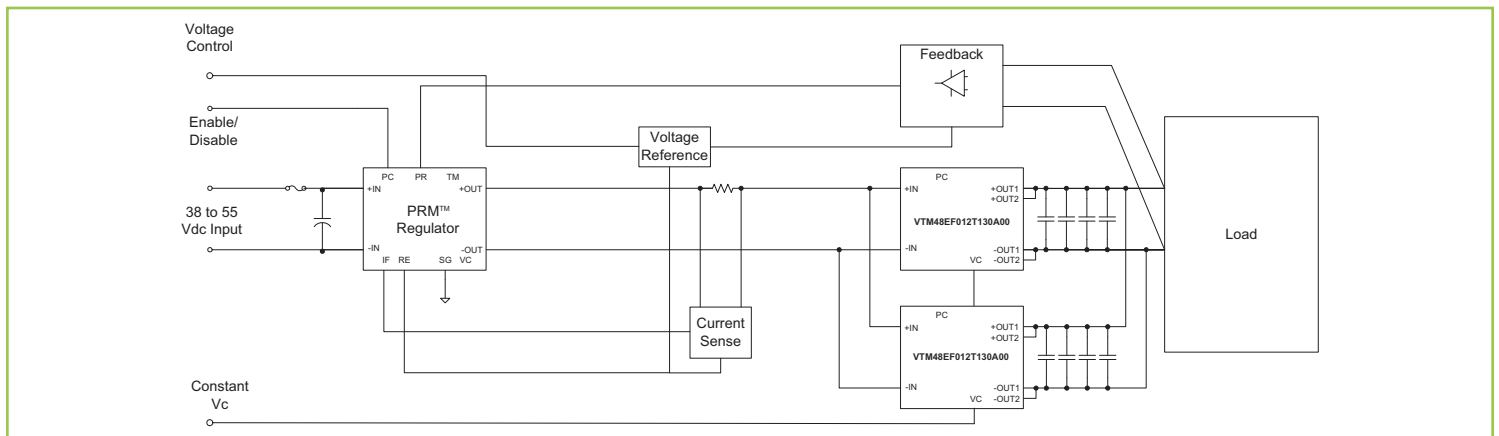

# VTM48EF012T130A00

## 1.0 ABSOLUTE MAXIMUM VOLTAGE RATINGS

The absolute maximum ratings below are stress ratings only. Operation at or beyond these maximum ratings can cause permanent damage to the device.

	MIN	MAX	UNIT		MIN	MAX	UNIT
+ IN to - IN	-1.0	60	V <sub>DC</sub>	IM to - IN	0	3.15	V <sub>DC</sub>
PC to - IN	-0.3	20	V <sub>DC</sub>	+ IN / - IN to + OUT / - OUT (hipot)		100	V <sub>DC</sub>
TM to - IN	-0.3	7	V <sub>DC</sub>	+ IN / - IN to + OUT / - OUT (working)		60	V <sub>DC</sub>
VC to - IN	-0.3	20	V <sub>DC</sub>	+ OUT to - OUT	-1.0	5.5	V <sub>DC</sub>

## 2.0 ELECTRICAL CHARACTERISTICS

Specifications apply over all line and load conditions unless otherwise noted; **Boldface** specifications apply over the temperature range of **-40°C < T<sub>J</sub> < 125°C (T-Grade)**; All other specifications are at **T<sub>J</sub> = 25°C** unless otherwise noted.

ATTRIBUTE	SYMBOL	CONDITIONS / NOTES	MIN	TYP	MAX	UNIT
Input voltage range	V <sub>IN</sub>	No external VC applied	<b>26</b>		<b>55</b>	V <sub>DC</sub>
		VC applied	<b>0</b>		<b>55</b>	
V <sub>IN</sub> slew rate	dV <sub>IN</sub> /dt				<b>1</b>	V/μs
V <sub>IN</sub> UV turn off	V <sub>IN_UV</sub>	Module latched shutdown, No external VC applied, I <sub>OUT</sub> = 130A		18	<b>26</b>	V
No Load power dissipation	P <sub>NL</sub>	V <sub>IN</sub> = 40 V	<b>1.5</b>		<b>5.0</b>	W
		V <sub>IN</sub> = 26 V to 55 V			<b>6</b>	
		V <sub>IN</sub> = 40 V, T <sub>C</sub> = 25°C		2.2	3.5	
		V <sub>IN</sub> = 26 V to 55 V, T <sub>C</sub> = 25°C			4.5	
Inrush current peak	I <sub>INRP</sub>	VC enable, V <sub>IN</sub> = 40 V, C <sub>OUT</sub> = 64400 μF, R <sub>LOAD</sub> = 7 mΩ		7	<b>11</b>	A
DC input current	I <sub>IN_DC</sub>				<b>4.5</b>	A
Transfer ratio	K	K = V <sub>OUT</sub> /V <sub>IN</sub> , I <sub>OUT</sub> = 0 A		1/40		V/V
Output voltage	V <sub>OUT</sub>	V <sub>OUT</sub> = V <sub>IN</sub> • K - I <sub>OUT</sub> • R <sub>OUT</sub> , Section 11				V
Output current (average)	I <sub>OUT_AVG</sub>	30°C < T <sub>C</sub> < 100°C, I <sub>OUT_max</sub> = - (2/7) • T <sub>C</sub> + 159			<b>130</b>	A
		T <sub>C</sub> = 30°C			150	
Output current (peak)	I <sub>OUT_PK</sub>	T <sub>PEAK</sub> < 10 ms, I <sub>OUT_AVG</sub> ≤ 130 A			<b>195</b>	A
Output power (average)	P <sub>OUT_AVG</sub>	I <sub>OUT_AVG</sub> ≤ 130 A			<b>178</b>	W
Efficiency (ambient)	η <sub>AMB</sub>	V <sub>IN</sub> = 40 V, I <sub>OUT</sub> = 130 A	88.0	90.1		%
		V <sub>IN</sub> = 26 V to 55 V, I <sub>OUT</sub> = 130 A	82.5			
		V <sub>IN</sub> = 40 V, I <sub>OUT</sub> = 65 A	91.0	92.5		
		V <sub>IN</sub> = 40 V, I <sub>OUT</sub> = 150 A	87	88.5		
Efficiency (hot)	η <sub>HOT</sub>	V <sub>IN</sub> = 40 V, T <sub>C</sub> = 100°C, I <sub>OUT</sub> = 130 A	86.2	88.5		%
Efficiency (over load range)	η <sub>20%</sub>	26 A < I <sub>OUT</sub> < 130 A	<b>80</b>			%
Output resistance (cold)	R <sub>OUT_COLD</sub>	T <sub>C</sub> = -40°C, I <sub>OUT</sub> = 130 A	0.33	0.53	0.72	mΩ
Output resistance (ambient)	R <sub>OUT_AMB</sub>	T <sub>C</sub> = 25°C, I <sub>OUT</sub> = 130 A	0.45	0.62	0.80	mΩ
Output resistance (hot)	R <sub>OUT_HOT</sub>	T <sub>C</sub> = 100°C, I <sub>OUT</sub> = 130 A	0.58	0.72	0.94	mΩ
Switching frequency	F <sub>SW</sub>		<b>1.14</b>	1.20	<b>1.26</b>	MHz
Output ripple frequency	F <sub>SW_RP</sub>		<b>2.28</b>	2.40	<b>2.52</b>	MHz
Output voltage ripple	V <sub>OUT_PP</sub>	C <sub>OUT</sub> = 0 F, I <sub>OUT</sub> = 130 A, V <sub>IN</sub> = 40 V, 20 MHz BW, Section 11		125	<b>175</b>	mV
Output inductance (parasitic)	L <sub>OUT_PAR</sub>	Frequency up to 30 MHz, Simulated J-lead model		150		pH
Output capacitance (internal)	C <sub>OUT_INT</sub>	Effective Value at 1 V <sub>OUT</sub>		350		μF
Output capacitance (external)	C <sub>OUT</sub>	VTM Standalone Operation. V <sub>IN</sub> pre-applied, VC enable			64400	μF
<b>PROTECTION</b>						
Overvoltage lockout	V <sub>IN_OVLO+</sub>	Module latched shutdown	<b>55.1</b>	58.1	<b>59.9</b>	V
Overvoltage lockout response time constant	T <sub>OVLO</sub>	Effective internal RC filter		0.25		μs
Output overcurrent trip	I <sub>OCP</sub>		<b>200</b>	250	<b>300</b>	A
Short circuit protection trip current	I <sub>SCP</sub>		260			A
Output overcurrent response time constant	T <sub>OCP</sub>	Effective internal RC filter (Integrative).		6.6		ms
Short circuit protection response time	T <sub>SCP</sub>	From detection to cessation of switching (Instantaneous)		1		μs
Thermal shutdown setpoint	T <sub>J_OTP</sub>		125	130	135	°C
Reverse inrush current protection		Reverse Inrush protection enabled for this product				

# VTM48EF012T130A00

## 3.0 SIGNAL CHARACTERISTICS

Specifications apply over all line and load conditions unless otherwise noted; **Boldface** specifications apply over the temperature range of  $-40^{\circ}\text{C} < T_J < 125^{\circ}\text{C}$  (T-Grade); All other specifications are at  $T_J = 25^{\circ}\text{C}$  unless otherwise noted.

### VTM CONTROL : VC

- Used to wake up powertrain circuit.
- A minimum of 11.5 V must be applied indefinitely for  $V_{IN} < 26$  V to ensure normal operation.
- VC slew rate must be within range for a successful start.
- PRM VC can be used as valid wake-up signal source.
- Internal Resistance used in "Adaptive Loop" compensation
- VC voltage may be continuously applied

SIGNAL TYPE	STATE	ATTRIBUTE	SYMBOL	CONDITIONS / NOTES	MIN	TYP	MAX	UNIT	
ANALOG INPUT	Steady	External VC voltage	$V_{VC\_EXT}$	Required for start up, and operation below 26 V. See Section 7.	<b>11.5</b>		<b>16.5</b>	V	
		VC current draw	$I_{VC}$	VC = 11.5 V, $V_{IN} = 0$ V		115	<b>150</b>	mA	
				VC = 11.5 V, $V_{IN} > 26$ V		0			
				VC = 16.5 V, $V_{IN} > 26$ V		0			
		VC internal diode rating	$D_{VC\_INT}$			100		V	
	VC internal resistor	$R_{VC\_INT}$			N/A		k $\Omega$		
	Start Up	VC internal resistor temperature coefficient	$T_{VC\_COEFF}$				N/A	ppm/ $^{\circ}\text{C}$	
				VC start up pulse	$V_{VC\_SP}$	Tpeak <18 ms		20	V
				VC slew rate	dVC/dt	Required for proper start up;	<b>0.02</b>		<b>0.25</b>
		VC inrush current	$I_{INR\_VC}$	VC = 16.5 V, dVC/dt = 0.25 V/ $\mu\text{s}$			<b>1</b>	A	
Transitional		VC to $V_{OUT}$ turn-on delay	$T_{ON}$	$V_{IN}$ pre-applied, PC floating, VC enable, $C_{PC} = 0$ $\mu\text{F}$			<b>500</b>	$\mu\text{s}$	
	VC to PC delay	$T_{VC\_PC}$	VC = 11.5 V to PC high, $V_{IN} = 0$ V, dVC/dt = 0.25 V/ $\mu\text{s}$		75	125	$\mu\text{s}$		
	Internal VC capacitance	$C_{VC\_INT}$	VC = 0 V		3.2		$\mu\text{F}$		

### PRIMARY CONTROL : PC

- The PC pin enables and disables the VTM. When held below 2 V, the VTM will be disabled.
- PC pin outputs 5 V during normal operation. PC pin is equal to 2.5 V during fault mode given  $V_{IN} > 26$  V or  $VC > 11.5$  V.
- After successful start up and under no fault condition, PC can be used as a 5 V regulated voltage source with a 2 mA maximum current.
- Module will shutdown when pulled low with an impedance less than 400  $\Omega$ .
- In an array of VTMs, connect PC pin to synchronize start up.
- PC pin cannot sink current and will not disable other modules during fault mode.

SIGNAL TYPE	STATE	ATTRIBUTE	SYMBOL	CONDITIONS / NOTES	MIN	TYP	MAX	UNIT
ANALOG OUTPUT	Steady	PC voltage	$V_{PC}$		<b>4.7</b>	5	<b>5.3</b>	V
		PC source current	$I_{PC\_OP}$				2	mA
		PC resistance (internal)	$R_{PC\_INT}$	Internal pull down resistor	<b>50</b>	150	<b>400</b>	k $\Omega$
	Start Up	PC source current	$I_{PC\_EN}$		<b>50</b>	100	<b>300</b>	$\mu\text{A}$
		PC capacitance (internal)	$C_{PC\_INT}$	Section 7			<b>1000</b>	pF
DIGITAL INPUT / OUPUT	Enable	PC resistance (external)	$R_{PC\_S}$		<b>60</b>			k $\Omega$
		PC voltage	$V_{PC\_EN}$		<b>2</b>	2.5	<b>3</b>	V
	Disable	PC voltage (disable)	$V_{PC\_DIS}$				<b>2</b>	V
		PC pull down current	$I_{PC\_PD}$		<b>5.1</b>			mA
	Transitional	PC disable time	$T_{PC\_DIS\_T}$			5		$\mu\text{s}$
		PC fault response time	$T_{FR\_PC}$	From fault to PC = 2 V		100		$\mu\text{s}$

### CURRENT MONITOR : IM

- The IM pin voltage varies between 0.1 V and 1.53 V representing the output current within  $\pm 25\%$  under all operating line temperature conditions between 50% and 100%.
- The IM pin provides a DC analog voltage proportional to the output current of the VTM.

SIGNAL TYPE	STATE	ATTRIBUTE	SYMBOL	CONDITIONS / NOTES	MIN	TYP	MAX	UNIT
ANALOG OUTPUT	Steady	IM Voltage (No Load)	$V_{IM\_NL}$	$T_J = 25^{\circ}\text{C}$ , $V_{IN} = 40$ V, $I_{OUT} = 0$ A	0.1	0.15	0.3	V
		IM Voltage (50%)	$V_{IM\_50\%}$	$T_J = 25^{\circ}\text{C}$ , $V_{IN} = 40$ V, $I_{OUT} = 65$ A		0.75		V
		IM Voltage (Full Load)	$V_{IM\_FL}$	$T_J = 25^{\circ}\text{C}$ , $V_{IN} = 40$ V, $I_{OUT} = 130$ A		1.53		V
		IM Gain	$A_{IM}$	$T_J = 25^{\circ}\text{C}$ , $V_{IN} = 40$ V, $I_{OUT} > 65$ A			12	mV/A
		IM Resistance (External)	$R_{IM\_EXT}$		<b>2.5</b>			M $\Omega$

# VTM48EF012T130A00

## TEMPERATURE MONITOR : TM

- The TM pin monitors the internal temperature of the VTM controller IC within an accuracy of  $\pm 5^{\circ}\text{C}$ .
- Can be used as a "Power Good" flag to verify that the VTM is operating.
- The TM pin has a room temperature setpoint of 3 V and approximate gain of 10 mV/ $^{\circ}\text{C}$ .
- Output drives Temperature Shutdown comparator

SIGNAL TYPE	STATE	ATTRIBUTE	SYMBOL	CONDITIONS / NOTES	MIN	TYP	MAX	UNIT
ANALOG OUTPUT	Steady	TM voltage	$V_{\text{TM\_AMB}}$	$T_j$ controller = 27°C	2.95	3.00	3.05	V
		TM source current	$I_{\text{TM}}$				100	$\mu\text{A}$
		TM gain	$A_{\text{TM}}$			10		mV/ $^{\circ}\text{C}$
		TM voltage ripple	$V_{\text{TM\_PP}}$	$C_{\text{TM}} = 0 \text{ F}, V_{\text{IN}} = 40 \text{ V}, I_{\text{OUT}} = 130 \text{ A}$		120	200	mV
DIGITAL OUTPUT (FAULT FLAG)	Disable	TM voltage	$V_{\text{TM\_DIS}}$			0		V
	Transitional	TM resistance (internal)	$R_{\text{TM\_INT}}$	Internal pull down resistor	25	40	50	k $\Omega$
		TM capacitance (external)	$C_{\text{TM\_EXT}}$				50	pF
		TM fault response time	$T_{\text{FR\_TM}}$	From fault to TM = 1.5 V		10		$\mu\text{s}$

## 4.0 TIMING DIAGRAM

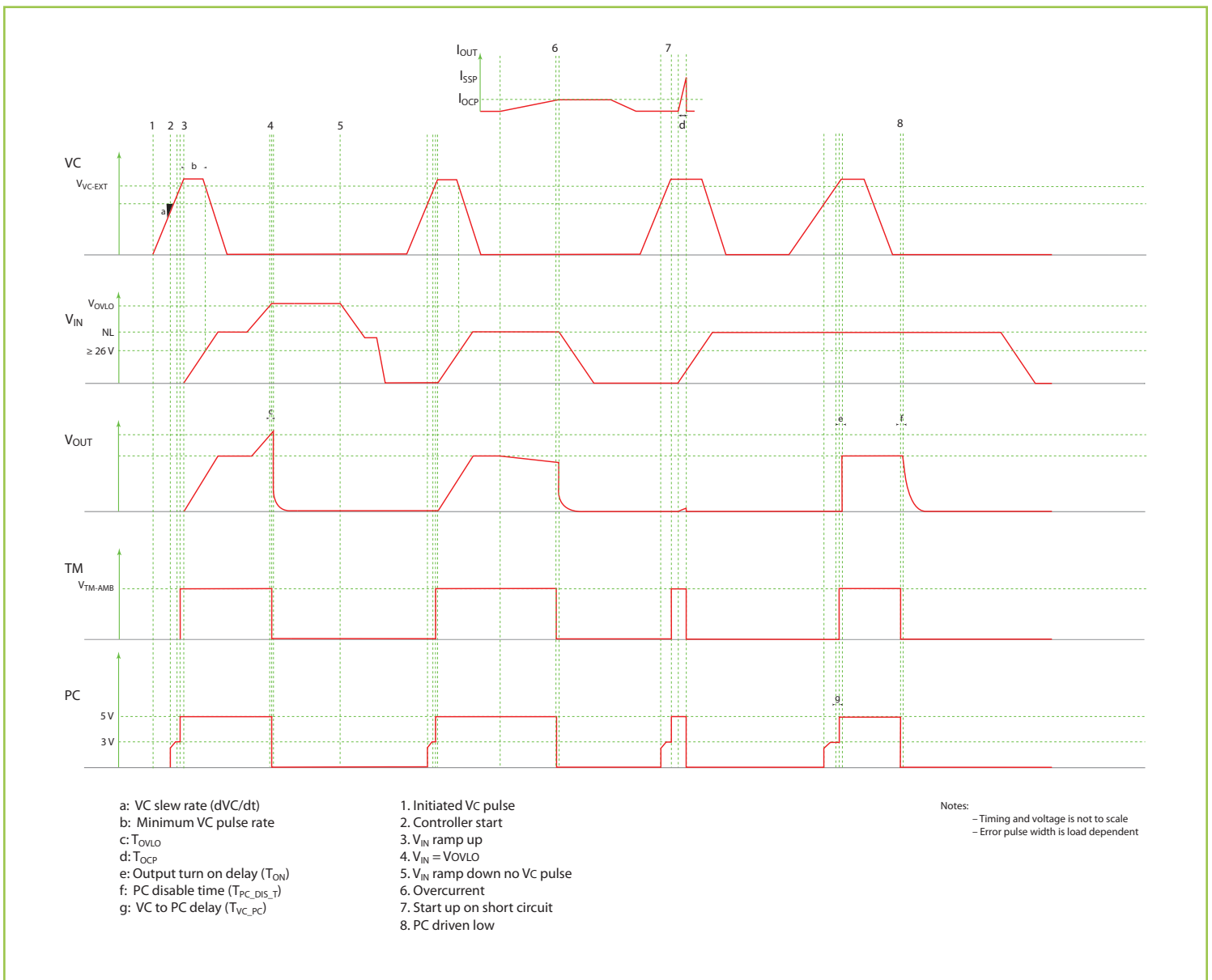

# VTM48EF012T130A00

## 5.0 APPLICATION CHARACTERISTICS

The following values, typical of an application environment, are collected at  $T_C = 25^\circ\text{C}$  unless otherwise noted. See associated figures for general trend data.

ATTRIBUTE	SYMBOL	CONDITIONS / NOTES	TYP	UNIT
No load power dissipation	$P_{NL}$	$V_{IN} = 40\text{ V}$ , PC enabled	2.1	W
Efficiency (ambient)	$\eta_{AMB}$	$V_{IN} = 40\text{ V}$ , $I_{OUT} = 130\text{ A}$	90.3	%
Efficiency (hot)	$\eta_{HOT}$	$V_{IN} = 40\text{ V}$ , $I_{OUT} = 130\text{ A}$ , $T_C = 100^\circ\text{C}$	88.7	%
Output resistance (cold)	$R_{OUT\_COLD}$	$V_{IN} = 40\text{ V}$ , $I_{OUT} = 130\text{ A}$ , $T_C = -40^\circ\text{C}$	0.5	$\text{m}\Omega$
Output resistance (ambient)	$R_{OUT\_AMB}$	$V_{IN} = 40\text{ V}$ , $I_{OUT} = 130\text{ A}$	0.6	$\text{m}\Omega$
Output resistance (hot)	$R_{OUT\_HOT}$	$V_{IN} = 40\text{ V}$ , $I_{OUT} = 130\text{ A}$ , $T_C = 100^\circ\text{C}$	0.8	$\text{m}\Omega$
Output voltage ripple	$V_{OUT\_PP}$	$C_{OUT} = 0\text{ F}$ , $I_{OUT} = 130\text{ A}$ , $V_{IN} = 40\text{ V}$ , 20 MHz BW, Section 12	142	mV
$V_{OUT}$ transient (positive)	$V_{OUT\_TRAN+}$	$I_{OUT\_STEP} = 0\text{ A TO } 130\text{ A}$ , $V_{IN} = 40\text{ V}$ , $I_{SLEW} = 36\text{ A}/\mu\text{s}$	40	mV
$V_{OUT}$ transient (negative)	$V_{OUT\_TRAN-}$	$I_{OUT\_STEP} = 130\text{ A TO } 0\text{ A}$ , $V_{IN} = 40\text{ V}$ , $I_{SLEW} = 23\text{ A}/\mu\text{s}$	60	mV

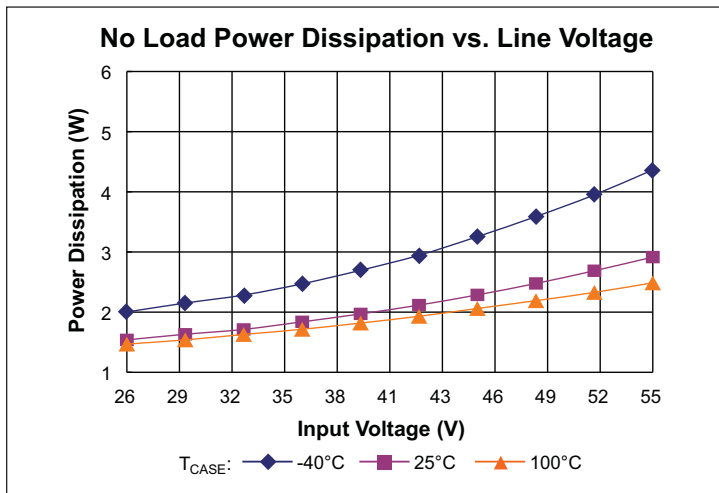

Figure 1 – No load power dissipation vs.  $V_{IN}$

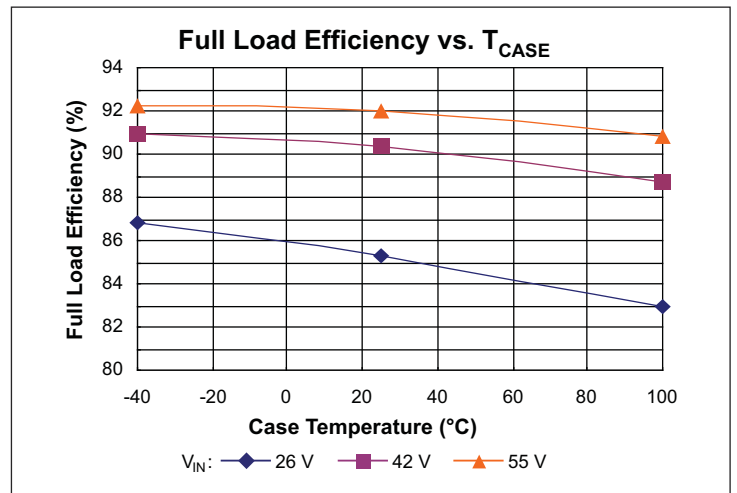

Figure 2 – Full load efficiency vs. temperature

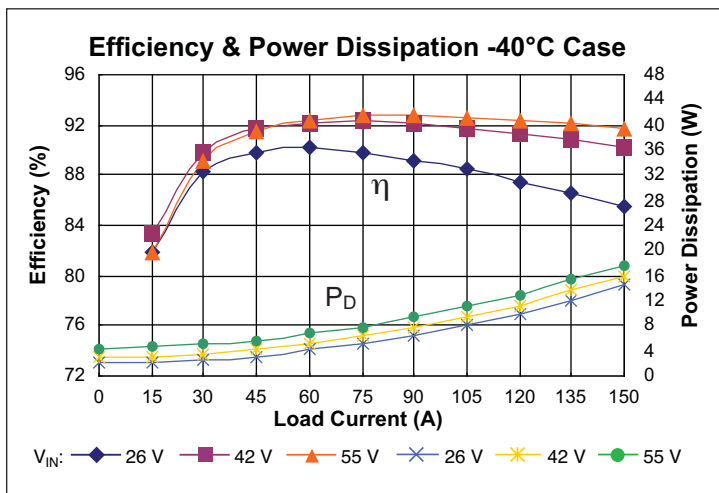

Figure 3 – Efficiency and power dissipation at  $-40^\circ\text{C}$

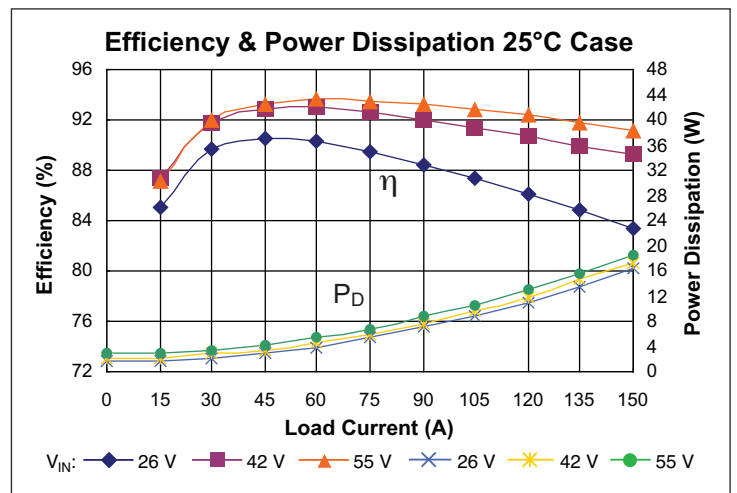

Figure 4 – Efficiency and power dissipation at  $25^\circ\text{C}$

# VTM48EF012T130A00

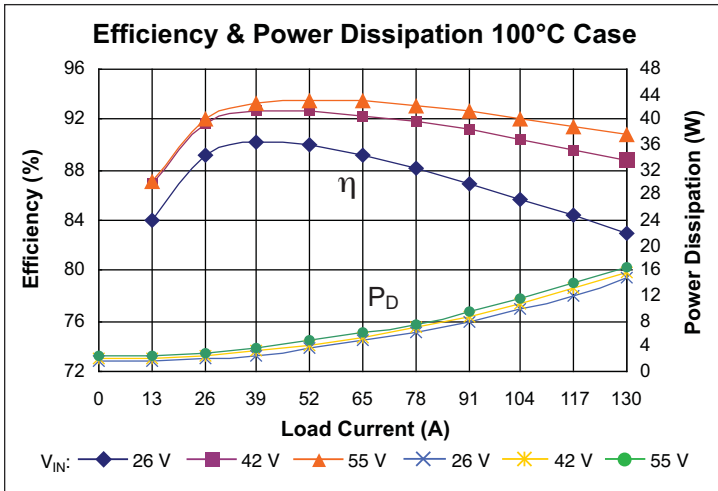

Figure 5 – Efficiency and power dissipation at 100°C

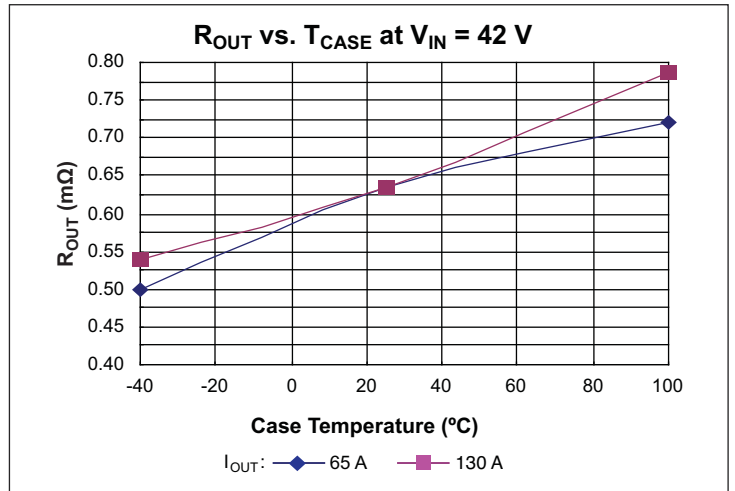

Figure 6 –  $R_{OUT}$  vs. temperature

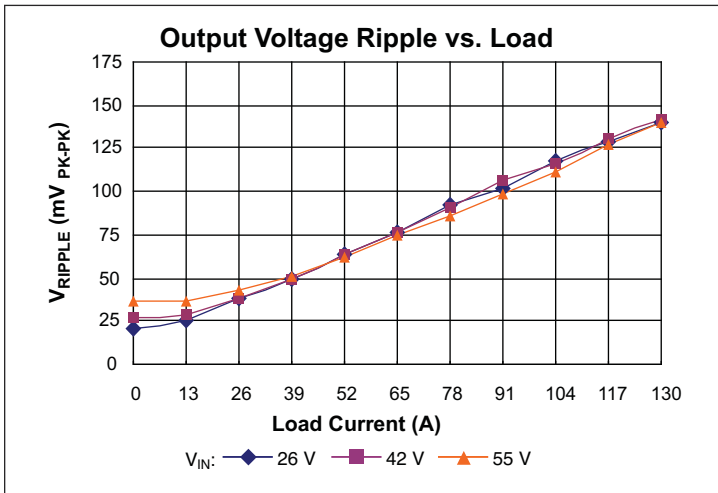

Figure 7 –  $V_{RIPPLE}$  vs.  $I_{OUT}$ ; No external  $C_{OUT}$ . Board mounted module, scope setting : 20 MHz analog BW

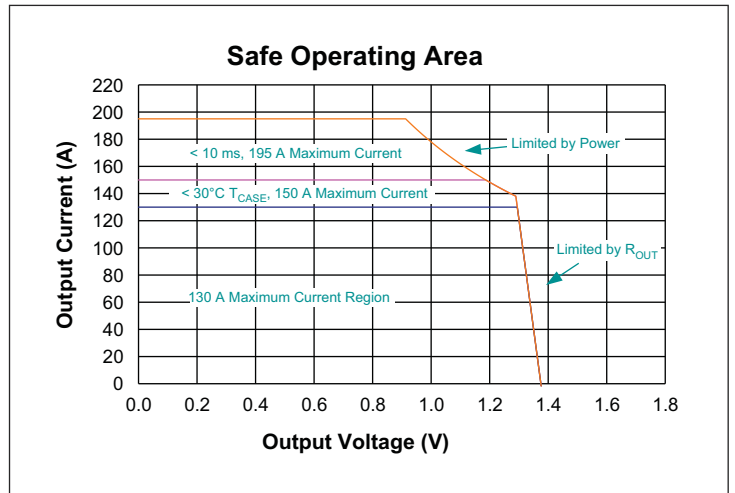

Figure 8 – Safe operating area

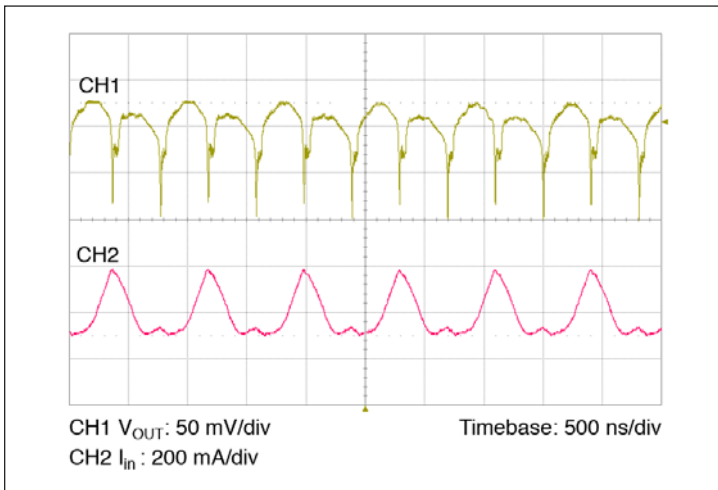

Figure 9 – Full load ripple, 100  $\mu F$   $C_{IN}$ ; No external  $C_{OUT}$ . Board mounted module, scope setting : 20 MHz analog BW

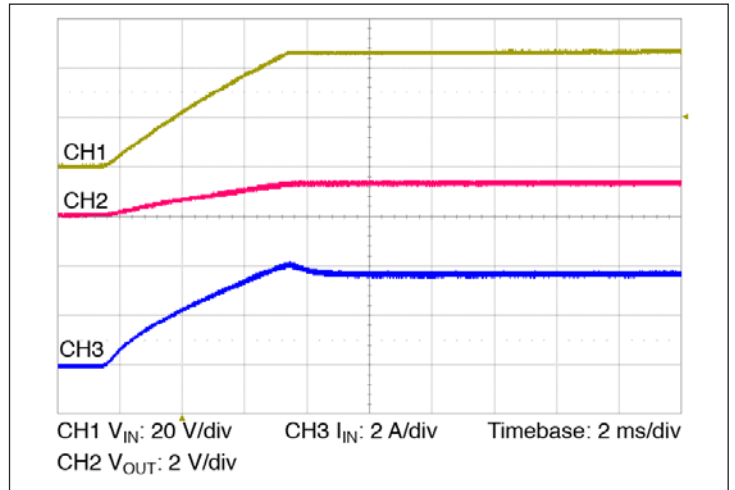

Figure 10 – Start up from application of  $V_{IN}$ ; VC pre-applied  $C_{OUT} = 64400 \mu F$

# VTM48EF012T130A00

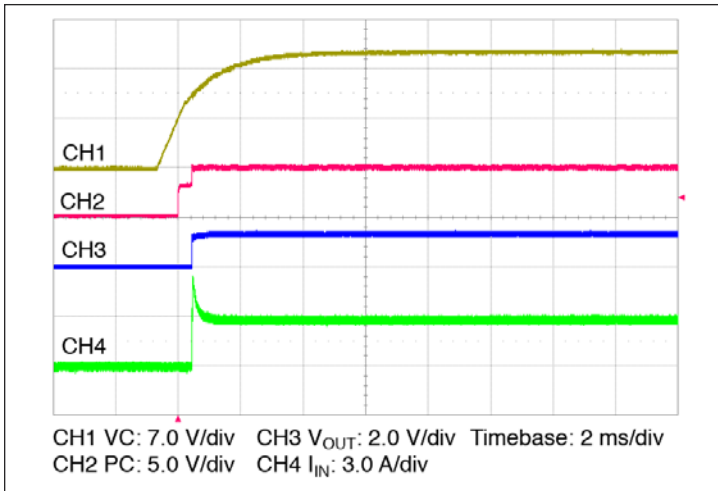

Figure 11 – Start up from application of VC;  $V_{IN}$  pre-applied  
 $C_{OUT} = 64400 \mu F$

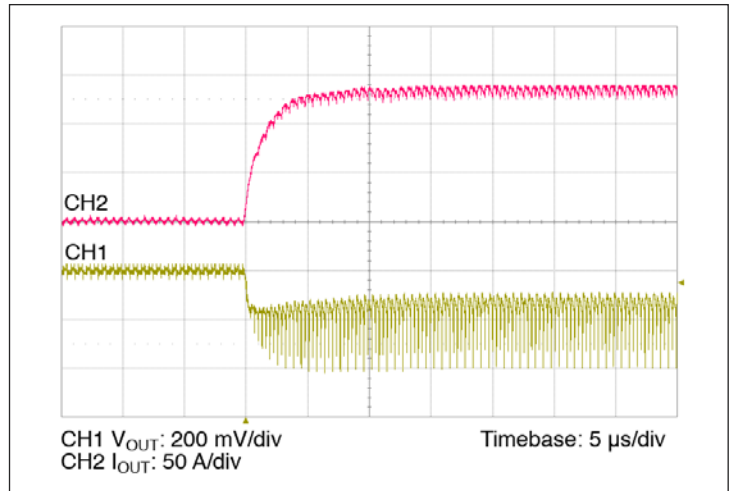

Figure 12 – 0 A– 130 A transient response:  
 $C_{IN} = 100 \mu F$ , no external  $C_{OUT}$

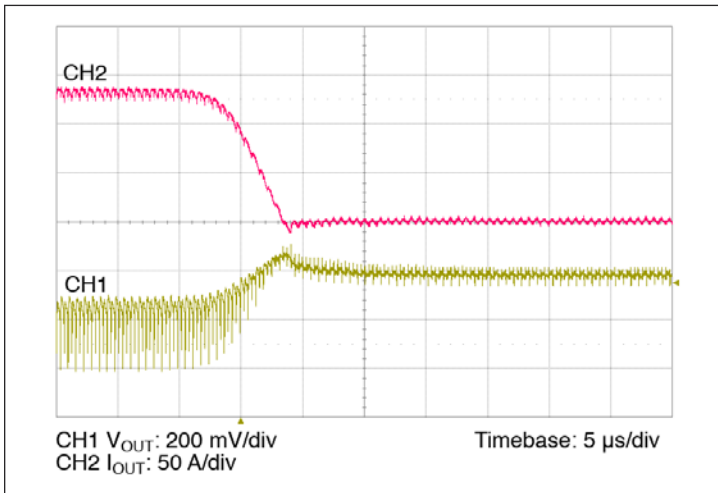

Figure 13 – 130 A – 0 A transient response:  
 $C_{IN} = 100 \mu F$ , no external  $C_{OUT}$

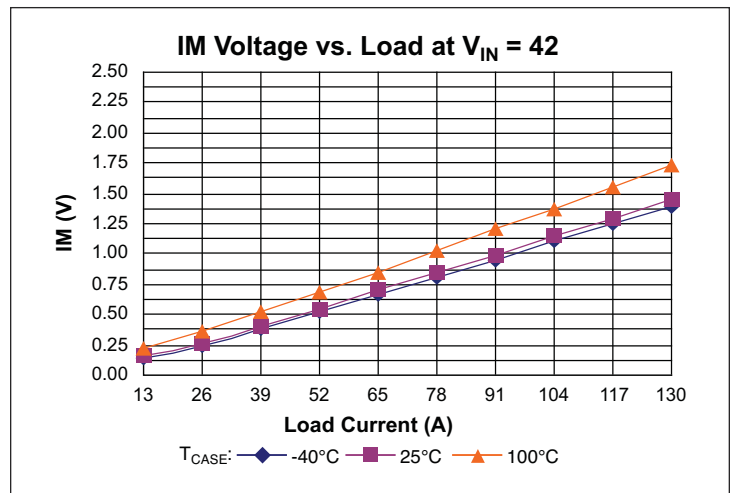

Figure 14 – IM voltage vs. load

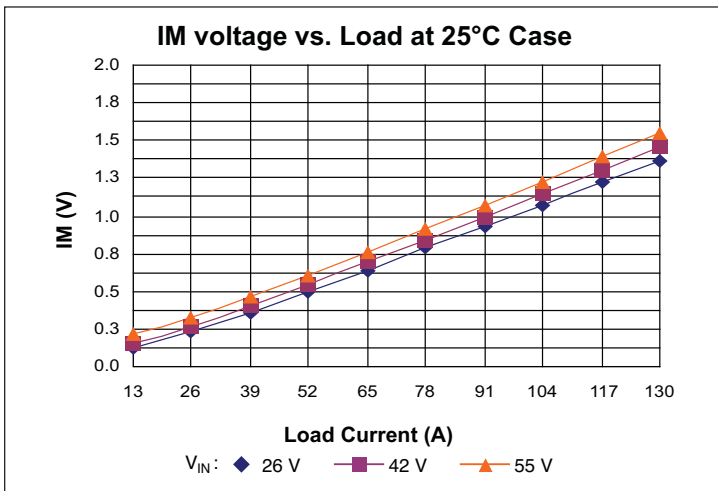

Figure 15 – IM voltage vs. load

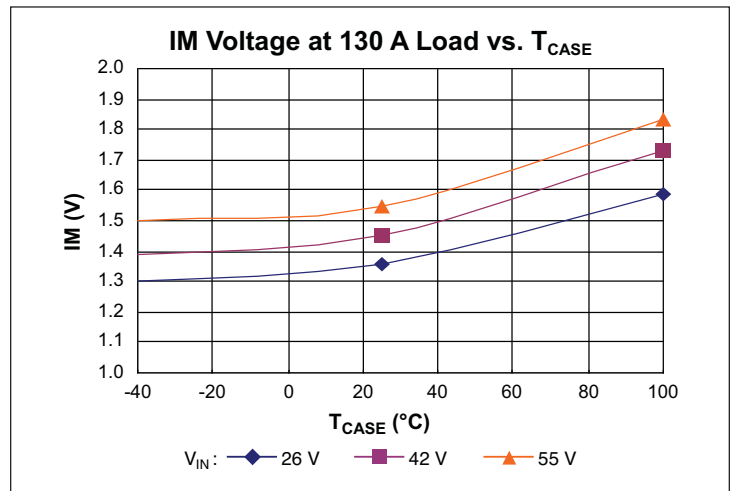

Figure 16 – Full load IM voltage vs.  $T_{CASE}$



# VTM48EF012T130A00

## 6.0 GENERAL CHARACTERISTICS

Specifications apply over all line and load conditions unless otherwise noted; **Boldface** specifications apply over the temperature range of  $-40^{\circ}\text{C} < T_J < 125^{\circ}\text{C}$  (T-Grade); All Other specifications are at  $T_J = 25^{\circ}\text{C}$  unless otherwise noted.

ATTRIBUTE	SYMBOL	CONDITIONS / NOTES	MIN	TYP	MAX	UNIT
<b>MECHANICAL</b>						
Length	L		32.25 / [1.270]	32.5 / [1.280]	32.75 / [1.289]	mm/[in]
Width	W		21.75 / [0.856]	22.0 / [0.866]	22.25 / [0.876]	mm/[in]
Height	H		6.48 / [0.255]	6.73 / [0.265]	6.98 / [0.275]	mm/[in]
Volume	Vol	No heat sink		4.81 / [0.294]		cm <sup>3</sup> /[in <sup>3</sup> ]
Weight	W			14.5 / [0.512]		g/[oz]
Lead finish		Nickel	0.51		2.03	μm
		Palladium	0.02		0.15	
		Gold	0.003		0.051	
<b>THERMAL</b>						
Operating temperature	T <sub>J</sub>	VTM48EF012T130A00 (T-Grade)	-40		125	°C
		VTM48EF012M130A00 (M-Grade)	N/A		N/A	°C
Thermal resistance	ϕ <sub>JC</sub>	Isothermal heatsink and isothermal internal PCB		1		°C/W
Thermal capacity				9		Ws/°C
<b>ASSEMBLY</b>						
Peak compressive force applied to case (Z-axis)		Supported by J-lead only			6	lbs
					5.41	lbs/in <sup>2</sup>
Storage temperature	T <sub>ST</sub>	VTM48EF012T130A00 (T-Grade)	-40		125	°C
		VTM48EF012M130A00 (M-Grade)	N/A		N/A	°C
Moisture sensitivity level	MSL	MSL 6, TOB = 4 hrs				
		MSL 5				
ESD withstand	ESD <sub>HBM</sub>	Human Body Model, "JEDEC JESD 22-A114D"	1000			V <sub>DC</sub>
	ESD <sub>CDM</sub>	Charge Device Model, "JEDEC JESD 22-C101-D"	400			
<b>SOLDERING</b>						
Peak temperature during reflow		MSL 6, TOB = 4 hrs			245	°C
		MSL 5			225	°C
Peak time above 245°C				60	90	s
Peak heating rate during reflow				1.5	3	°C/s
Peak cooling rate post reflow				1.5	6	°C/s
<b>SAFETY</b>						
Working voltage (IN – OUT)	V <sub>IN_OUT</sub>				<b>60</b>	V <sub>DC</sub>
Isolation voltage (hipot)	V <sub>HIPOT</sub>		<b>100</b>			V <sub>DC</sub>
Isolation capacitance	C <sub>IN_OUT</sub>	Unpowered unit	<b>18000</b>	20000	<b>22000</b>	pF
Isolation resistance	R <sub>IN_OUT</sub>		<b>10</b>			MΩ
MTBF		MIL-HDBK-217 Plus Parts Count; 25°C Ground Benign, Stationary, Indoors / Computer Profile		1.56		MHrs
		Telcordia Issue 2 - Method I Case III; Ground Benign, Controlled		5.44		MHrs
Agency approvals / standards		cTUVus				
		cURus				
		CE Mark				
		RoHS 6 of 6				



## 7.0 USING THE CONTROL SIGNALS VC, PC, TM, IM

The **VTM Control (VC)** pin is an input pin which powers the internal VCC circuitry when within the specified voltage range of 11.5 V to 16.5 V. This voltage is required for VTM™ transformer start up and must be applied as long as the input is below 26 V. In order to ensure a proper start, the slew rate of the applied voltage must be within the specified range.

Some additional notes on the using the VC pin:

- In most applications, the VTM module will be powered by an upstream PRM™ regulator which provides a 10 ms VC pulse during start up. In these applications the VC pins of the PRM and VTM should be tied together.
- The VC voltage can be applied indefinitely allowing for continuous operation down to 0 V<sub>IN</sub>.
- The fault response of the VTM module is latching. A positive edge on VC is required in order to restart the unit. If VC is continuously applied the PC pin may be toggled to restart the VTM module.

**Primary Control (PC)** pin can be used to accomplish the following functions:

- Delayed start: Upon the application of VC, the PC pin will source a constant 100 µA current to the internal RC network. Adding an external capacitor will allow further delay in reaching the 2.5 V threshold for module start.
- Auxiliary voltage source: Once enabled in regular operational conditions (no fault), each VTM PC provides a regulated 5 V, 2 mA voltage source.
- Output disable: PC pin can be actively pulled down in order to disable the module. Pull down impedance shall be lower than 400 Ω.
- Fault detection flag: The PC 5 V voltage source is internally turned off as soon as a fault is detected. It is important to notice that PC doesn't have current sink capability. Therefore, in an array, PC line will not be capable of disabling neighboring modules if a fault is detected.
- Fault reset: PC may be toggled to restart the unit if VC is continuously applied.

**Temperature Monitor (TM)** pin provides a voltage proportional to the absolute temperature of the converter control IC.

It can be used to accomplish the following functions:

- Monitor the control IC temperature: The temperature in Kelvin is equal to the voltage on the TM pin scaled by 100. (i.e. 3.0 V = 300 K = 27°C). If a heat sink is applied, TM can be used to thermally protect the system.
- Fault detection flag: The TM voltage source is internally turned off as soon as a fault is detected. For system monitoring purposes (microcontroller interface) faults are detected on falling edges of TM signal.

**Current Monitor (IM)** pin provides a voltage proportional to the output current of the VTM module. The nominal voltage will vary between 0.15 V and 1.53 V over the output current range of the VTM module (See Figures 14–16). The accuracy of the IM pin will be within 25% under all line and temperature conditions between 50% and 100% load.

## 8.0 START UP BEHAVIOR

Depending on the sequencing of the VC with respect to the input voltage, the behavior during start up will vary as follows:

- Normal operation (VC applied prior to V<sub>IN</sub>): In this case the controller is active prior to ramping the input. When the input voltage is applied, the VTM module output voltage will track the input (See Figure 10). The inrush current is determined by the input voltage rate of rise and output capacitance. If the VC voltage is removed prior to the input reaching 26 V, the VTM may shut down.
- Stand-alone operation (VC applied after V<sub>IN</sub>): In this case the VTM module output will begin to rise upon the application of the VC voltage (See Figure 11). The Adaptive Soft Start Circuit (See Section 11) may vary the output rate of rise in order to limit the inrush current to its maximum level. When starting into high capacitance, or a short, the output current will be limited for a maximum of 120 µ/sec. After this period, the Adaptive Soft Start Circuit will time out and the VTM module may shut down. No restart will be attempted until VC is re-applied or PC is toggled. The maximum output capacitance is limited to 64400 µF in this mode of operation to ensure a successful start.

## 9.0 THERMAL CONSIDERATIONS

V•I Chip™ products are multi-chip modules whose temperature distribution varies greatly for each part number as well as with the input / output conditions, thermal management and environmental conditions. Maintaining the top of the VTM48EF012T130A00 case to less than 100°C will keep all junctions within the V•I Chip module below 125°C for most applications.

The percent of total heat dissipated through the top surface versus through the J-lead is entirely dependent on the particular mechanical and thermal environment. The heat dissipated through the top surface is typically 60%. The heat dissipated through the J-lead onto the PCB board surface is typically 40%. Use 100% top surface dissipation when designing for a conservative cooling solution.

It is not recommended to use a V•I Chip module for an extended period of time at full load without proper heat sinking.

# VTM48EF012T130A00

## 10.0 VTM48EF012T130A00 BLOCK DIAGRAM

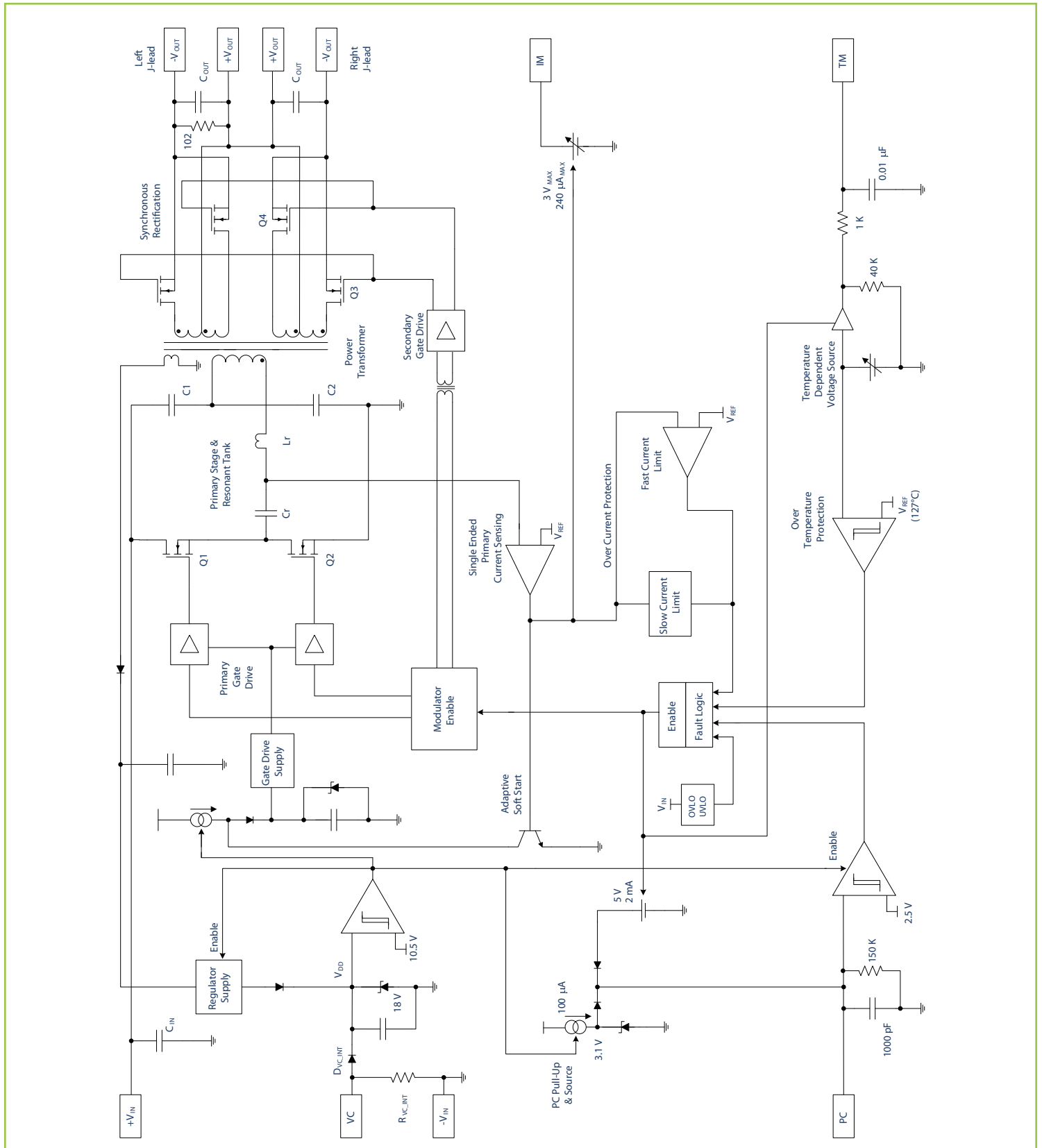

## 11.0 SINE AMPLITUDE CONVERTER™ POINT OF LOAD CONVERSION

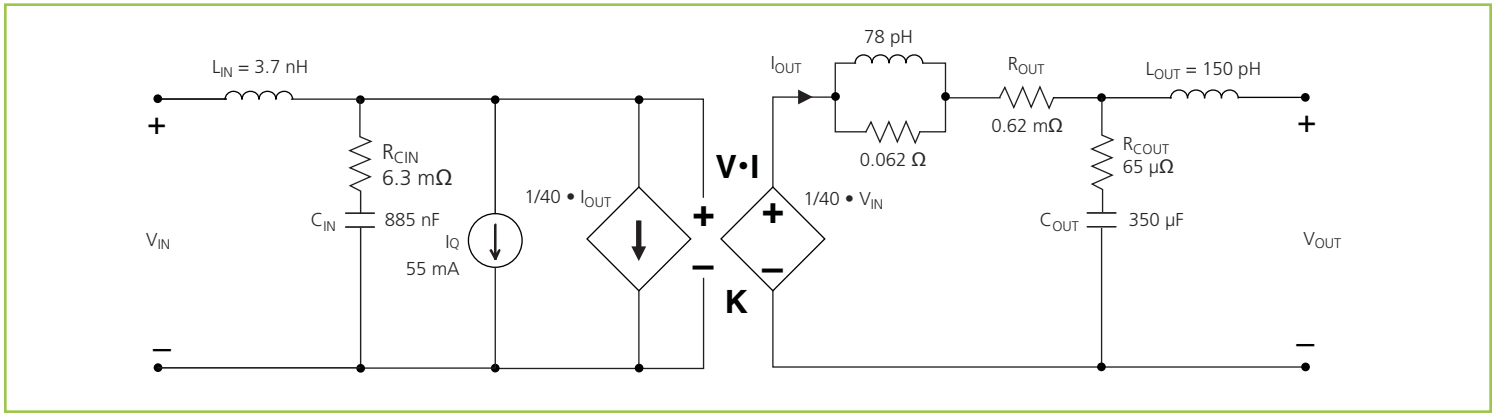

**Figure 17** – V\*I Chip™ AC model

The Sine Amplitude Converter (SAC™) uses a high frequency resonant tank to move energy from input to output. (The resonant tank is formed by Cr and leakage inductance Lr in the power transformer windings as shown in the VTM™ module Block Diagram. See Section 10). The resonant LC tank, operated at high frequency, is amplitude modulated as a function of input voltage and output current. A small amount of capacitance embedded in the input and output stages of the module is sufficient for full functionality and is key to achieving power density.

The VTM48EF012T130A00 SAC can be simplified into the following model: At no load:

$$V_{OUT} = V_{IN} \cdot K \quad (1)$$

K represents the “turns ratio” of the SAC. Rearranging Eq (1):

$$K = \frac{V_{OUT}}{V_{IN}} \quad (2)$$

In the presence of load,  $V_{OUT}$  is represented by:

$$V_{OUT} = V_{IN} \cdot K - I_{OUT} \cdot R_{OUT} \quad (3)$$

and  $I_{OUT}$  is represented by:

$$I_{OUT} = \frac{I_{IN} - I_Q}{K} \quad (4)$$

$R_{OUT}$  represents the impedance of the SAC, and is a function of

the  $R_{DS(ON)}$  of the input and output MOSFETs and the winding resistance of the power transformer.  $I_Q$  represents the quiescent current of the SAC control and gate drive circuitry. The use of DC voltage transformation provides additional interesting attributes. Assuming that  $R_{OUT} = 0 \Omega$  and  $I_Q = 0 A$ , Eq. (3) now becomes Eq. (1) and is essentially load independent, resistor R is now placed in series with  $V_{IN}$  as shown in Figure 18.

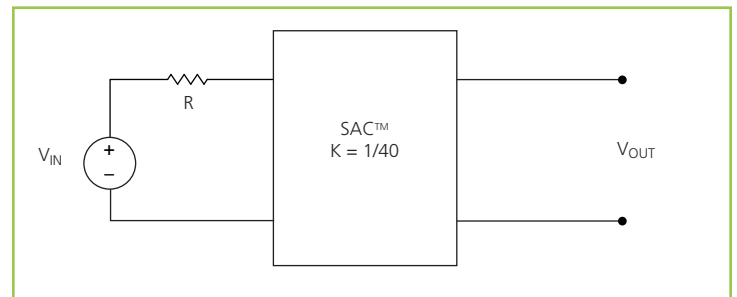

**Figure 18** –  $K = 1/32$  Sine Amplitude Converter with series input resistor

The relationship between  $V_{IN}$  and  $V_{OUT}$  becomes:

$$V_{OUT} = (V_{IN} - I_{IN} \cdot R) \cdot K \quad (5)$$

Substituting the simplified version of Eq. (4) ( $I_Q$  is assumed = 0 A) into Eq. (5) yields:

$$V_{OUT} = V_{IN} \cdot K - I_{OUT} \cdot R \cdot K^2 \quad (6)$$

This is similar in form to Eq. (3), where  $R_{OUT}$  is used to represent the characteristic impedance of the SAC™. However, in this case a real R on the input side of the SAC is effectively scaled by  $K^2$  with respect to the output.

Assuming that  $R = 1 \Omega$ , the effective R as seen from the secondary side is #REF! mΩ, with  $K = 1/40$  as shown in Figure 18.

A similar exercise should be performed with the addition of a capacitor or shunt impedance at the input to the SAC. A switch in series with  $V_{IN}$  is added to the circuit. This is depicted in Figure 19.

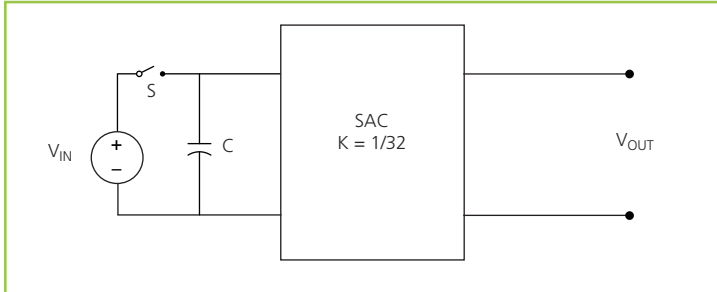

**Figure 19** – Sine Amplitude Converter™ with input capacitor

A change in  $V_{IN}$  with the switch closed would result in a change in capacitor current according to the following equation:

$$I_C(t) = C \frac{dV_{IN}}{dt} \quad (7)$$

Assume that with the capacitor charged to  $V_{IN}$ , the switch is opened and the capacitor is discharged through the idealized SAC. In this case,

$$I_C = I_{OUT} \cdot K \quad (8)$$

Substituting Eq. (1) and (8) into Eq. (7) reveals:

$$I_{OUT} = \frac{C}{K^2} \cdot \frac{dV_{OUT}}{dt} \quad (9)$$

The equation in terms of the output has yielded a  $K^2$  scaling factor for C, specified in the denominator of the equation. A K factor less than unity, results in an effectively larger capacitance on the output when expressed in terms of the input. With a  $K=1/40$  as shown in Figure 19,  $C=1 \mu\text{F}$  would appear as  $C=1600 \mu\text{F}$  when viewed from the output.

Low impedance is a key requirement for powering a high-current, low voltage load efficiently. A switching regulation stage should have minimal impedance while simultaneously providing appropriate filtering for any switched current. The use of a SAC between the regulation stage and the point of load provides a dual benefit of scaling down series impedance leading back to the source and scaling up shunt capacitance or energy storage as a function of its K factor squared. However, the benefits are not useful if the series impedance of the SAC is too high. The impedance of the SAC must be low, i.e. well beyond the crossover frequency of the system.

A solution for keeping the impedance of the SAC low involves switching at a high frequency. This enables small magnetic components because magnetizing currents remain low. Small magnetics mean small path lengths for turns. Use of low loss core material at high frequencies also reduces core losses.

The two main terms of power loss in the VTM™ module are:

- No load power dissipation ( $P_{NL}$ ): defined as the power used to power up the module with an enabled powertrain at no load.
- Resistive loss ( $R_{OUT}$ ): refers to the power loss across the VTM™ transformer modeled as pure resistive impedance.

$$P_{DISSIPATED} = P_{NL} + P_{ROUT} \quad (10)$$

Therefore,

$$P_{OUT} = P_{IN} - P_{DISSIPATED} = P_{IN} - P_{NL} - P_{ROUT} \quad (11)$$

The above relations can be combined to calculate the overall module efficiency:

$$\eta = \frac{P_{OUT}}{P_{IN}} = \frac{P_{IN} - P_{NL} - P_{ROUT}}{P_{IN}} \quad (12)$$

$$= \frac{V_{IN} \cdot I_{IN} - P_{NL} - (I_{OUT})^2 \cdot R_{OUT}}{V_{IN} \cdot I_{IN}}$$

$$= 1 - \left( \frac{P_{NL} + (I_{OUT})^2 \cdot R_{OUT}}{V_{IN} \cdot I_{IN}} \right)$$

## 12.0 INPUT AND OUTPUT FILTER DESIGN

A major advantage of a SAC™ system versus a conventional PWM converter is that the former does not require large functional filters. The resonant LC tank, operated at extreme high frequency, is amplitude modulated as a function of input voltage and output current and efficiently transfers charge through the isolation transformer. A small amount of capacitance embedded in the input and output stages of the module is sufficient for full functionality and is key to achieving high power density.

This paradigm shift requires system design to carefully evaluate external filters in order to:

1. Guarantee low source impedance.

To take full advantage of the VTM™ transformer dynamic response, the impedance presented to its input terminals must be low from DC to approximately 5 MHz. Input capacitance may be added to improve transient performance or compensate for high source impedance.

2. Further reduce input and/or output voltage ripple without sacrificing dynamic response.

Given the wide bandwidth of the VTM module, the source response is generally the limiting factor in the overall system response. Anomalies in the response of the source will appear at the output of the VTM module multiplied by its K factor.

3. Protect the module from overvoltage transients imposed by the system that would exceed maximum ratings and cause failures.

The V•I Chip™ module input/output voltage ranges must not be exceeded. An internal overvoltage lockout function prevents operation outside of the normal operating input range. Even during this condition, the powertrain is exposed to the applied voltage and power MOSFETs must withstand it.

## 13.0 CAPACITIVE FILTERING CONSIDERATIONS FOR A SINE AMPLITUDE CONVERTER™

It is important to consider the impact of adding input and output capacitance to a Sine Amplitude Converter on the system as a whole. Both the capacitance value and the effective impedance of the capacitor must be considered.

A Sine Amplitude Converter has a DC  $R_{OUT}$  value which has already been discussed in section 11. The AC  $R_{OUT}$  of the SAC contains several terms:

- Resonant tank impedance
- Input lead inductance and internal capacitance
- Output lead inductance and internal capacitance

The values of these terms are shown in the behavioral model in section 11. It is important to note on which side of the transformer these impedances appear and how they reflect across the transformer given the K factor.

The overall AC impedance varies from model to model. For most models it is dominated by DC  $R_{OUT}$  value from DC to beyond 500 KHz. The behavioral model in section 11 should be used to approximate the AC impedance of the specific model.

Any capacitors placed at the output of the VTM reflect back to the input of the VTM module by the square of the K factor (Eq. 9) with the impedance of the VTM module appearing in series. It is very important to keep this in mind when using a PRM™ regulator to power the VTM module. Most PRM modules have a limit on the maximum amount of capacitance that can be applied to the output. This capacitance includes both the PRM output capacitance and the VTM output capacitance reflected back to the input. In PRM remote sense applications, it is important to consider the reflected value of VTM output capacitance when designing and compensating the PRM control loop.

Capacitance placed at the input of the VTM module appear to the load reflected by the K factor with the impedance of the VTM module in series. In step-down ratios, the effective capacitance is increased by the K factor. The effective ESR of the capacitor is decreased by the square of the K factor, but the impedance of the module appears in series. Still, in most step-down VTM modules an electrolytic capacitor placed at the input of the module will have a lower effective impedance compared to an electrolytic capacitor placed at the output. This is important to consider when placing capacitors at the output of the module. Even though the capacitor may be placed at the output, the majority of the AC current will be sourced from the lower impedance, which in most cases will be the module. This should be studied carefully in any system design using a module. In most cases, it should be clear that electrolytic output capacitors are not necessary to design a stable, well-bypassed system.

# VTM48EF012T130A00

## 14.0 CURRENT SHARING

The SAC™ topology bases its performance on efficient transfer of energy through a transformer without the need of closed loop control. For this reason, the transfer characteristic can be approximated by an ideal transformer with some resistive drop and positive temperature coefficient.

This type of characteristic is close to the impedance characteristic of a DC power distribution system, both in behavior (AC dynamic) and absolute value (DC dynamic).

When connected in an array with the same K factor, the VTM module will inherently share the load current (typically 5%) with parallel units according to the equivalent impedance divider that the system implements from the power source to the point of load.

Some general recommendations to achieve matched array impedances:

- Dedicate common copper planes within the PCB to deliver and return the current to the modules.
- Provide the PCB layout as symmetric as possible.
- Apply same input / output filters (if present) to each unit.

For further details see [AN:016 Using BCM™ Bus Converters in High Power Arrays](#).

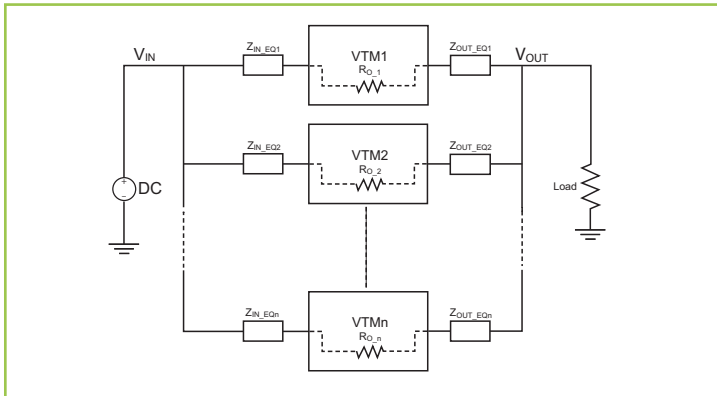

Figure 20 – VTM™ Transformer array

## 15.0 FUSE SELECTION

In order to provide flexibility in configuring power systems V•I Chip™ products are not internally fused. Input line fusing of V•I Chip products is recommended at system level to provide thermal protection in case of catastrophic failure.

The fuse shall be selected by closely matching system requirements with the following characteristics:

- Current rating (usually greater than maximum current of VTM module)
- Maximum voltage rating (usually greater than the maximum possible input voltage)
- Ambient temperature
- Nominal melting  $I^2t$

## 16.0 REVERSE INRUSH CURRENT PROTECTION

The VTM48EF012T130A00 provides reverse inrush protection which prevents reverse current flow until the input voltage is high enough to first establish current flow in the forward direction. In the event that there is a DC voltage present on the output before the VTM module is powered up, this feature protects sensitive loads from excessive  $dV/dT$  during power up as shown in Figure 21.

If a voltage is present at the output of the VTM module which satisfies the condition  $V_{OUT} > V_{IN} \cdot K$  after a successful power up the energy will be transferred from secondary to primary. The input to output ratio of the VTM module will be maintained. The VTM module will continue to operate in reverse as long as the input and output voltages are within the specified range. The VTM48EF012T130A00 has not been qualified for continuous reverse operation.

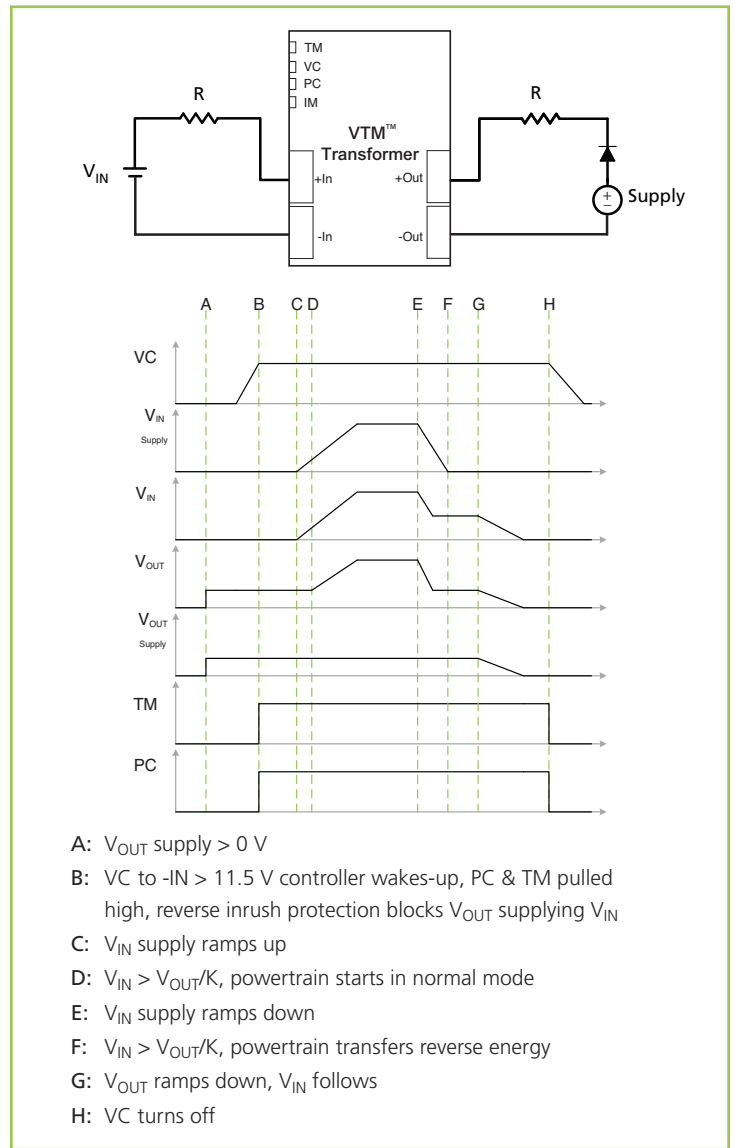

Figure 21 – Reverse inrush protection

# VTM48EF012T130A00

## 17.0 LAYOUT CONSIDERATIONS

The VTM48EF012T130A00 requires equal current density along the output J-leads to achieve rated efficiency and output power level. The negative output J-leads are not connected internally and must be connected on the board as close to the VTM™ transformer as possible. The layout must also prevent the high output current of the VTM48EF012T130A00 from interfering with the input-referenced signals.

To achieve these requirements, the following layout guidelines are recommended:

- The total current path length from any point on the  $V_{+OUT}$  J-leads to the corresponding point on the  $V_{-OUT}$  J-leads should be equal (see Figure 21).
- Use vias along the negative output J-leads to connect the negative output to a common power plane.
- Use sufficient copper weight and number of layers to carry the output current to the load or to the output connectors.
- Be sure to include enough vias along both the positive and negative J leads to distribute the current among the layers of the PCB.
- Do not run input-referenced signal traces (VC, PC, TM and IM) between the layers of the secondary outputs.
- Run the input-referenced signal traces (VC, PC, TM and IM) such that  $V_{-IN}$  shields the signals. See [AN:005 FPA Printed Circuit Board Layout Guidelines](#) for more details.

Equalizing the current paths is most easily accomplished by centering the VTM module output J-leads between the output connections of the PCB and by designing the board such that the layout is symmetric from both sides of the output and from the front and back ends of the output as shown in Figures 22 and 23.

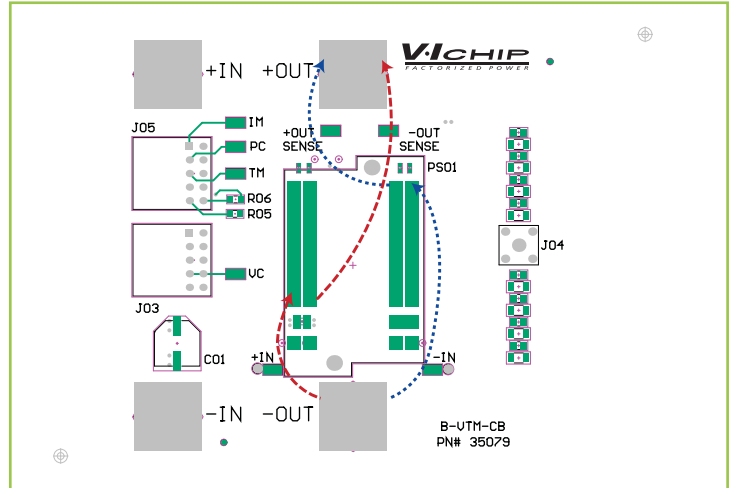

Figure 21 – Equal current path

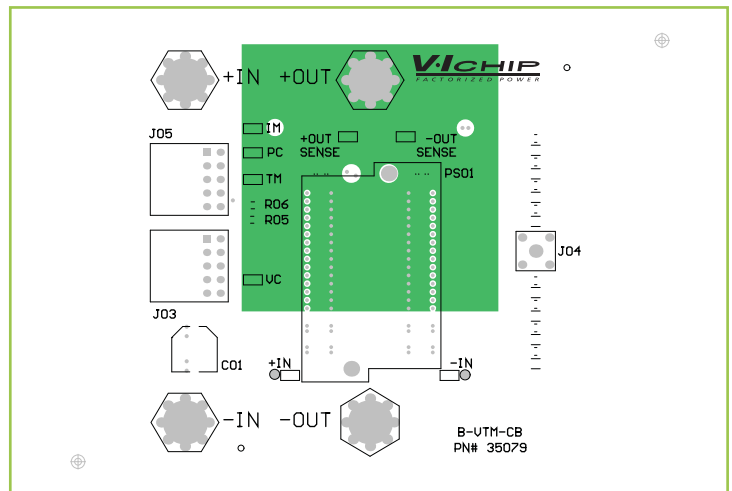

Figure 22 – Symmetric layout

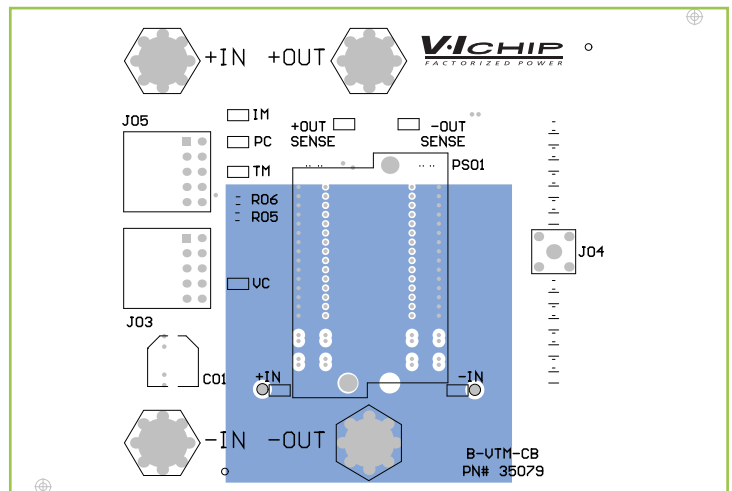
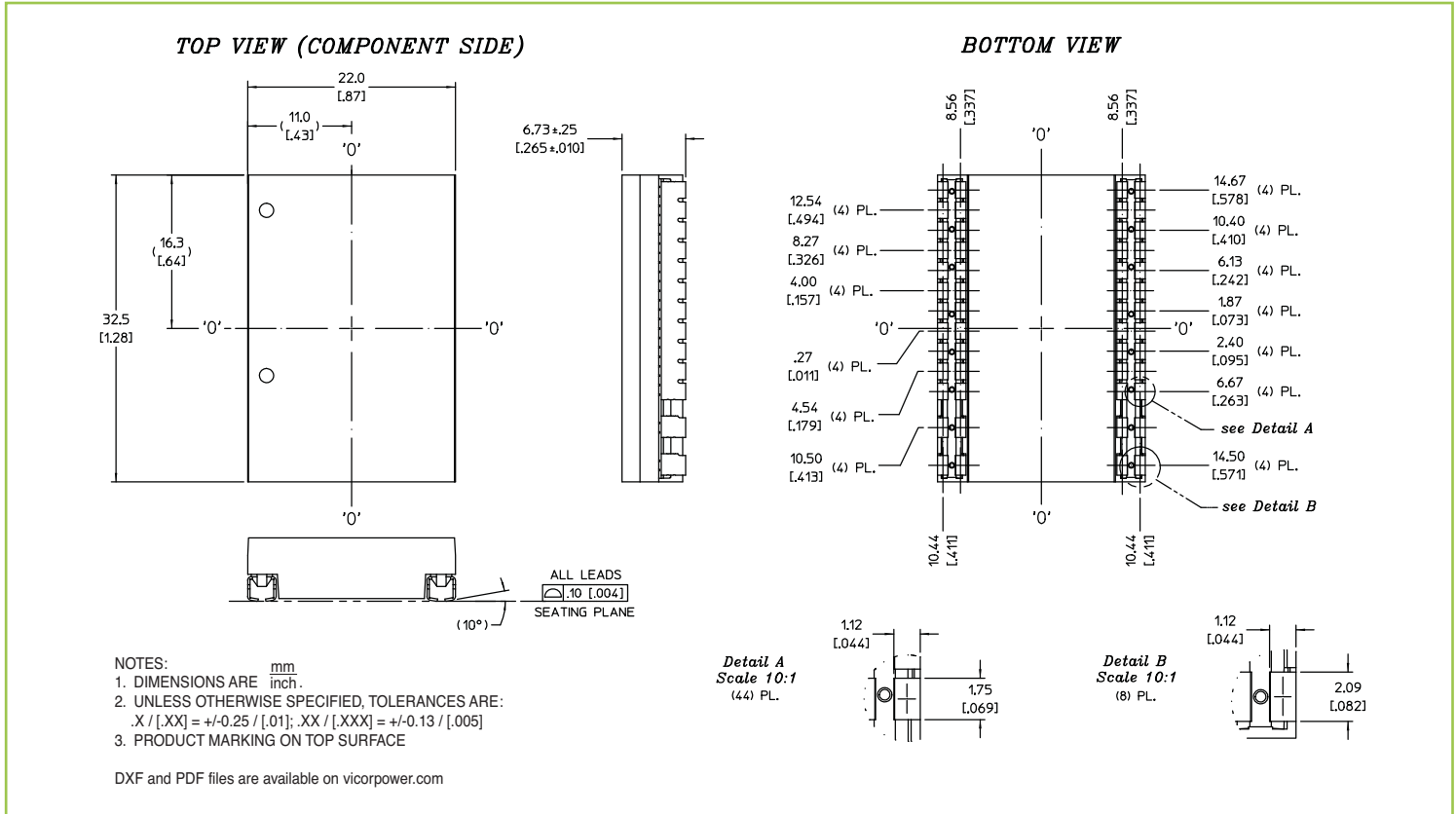

Figure 23 – Symmetric layout



# VTM48EF012T130A00

## 17.1 MECHANICAL DRAWING



## 17.2 RECOMMENDED LAND PATTERN

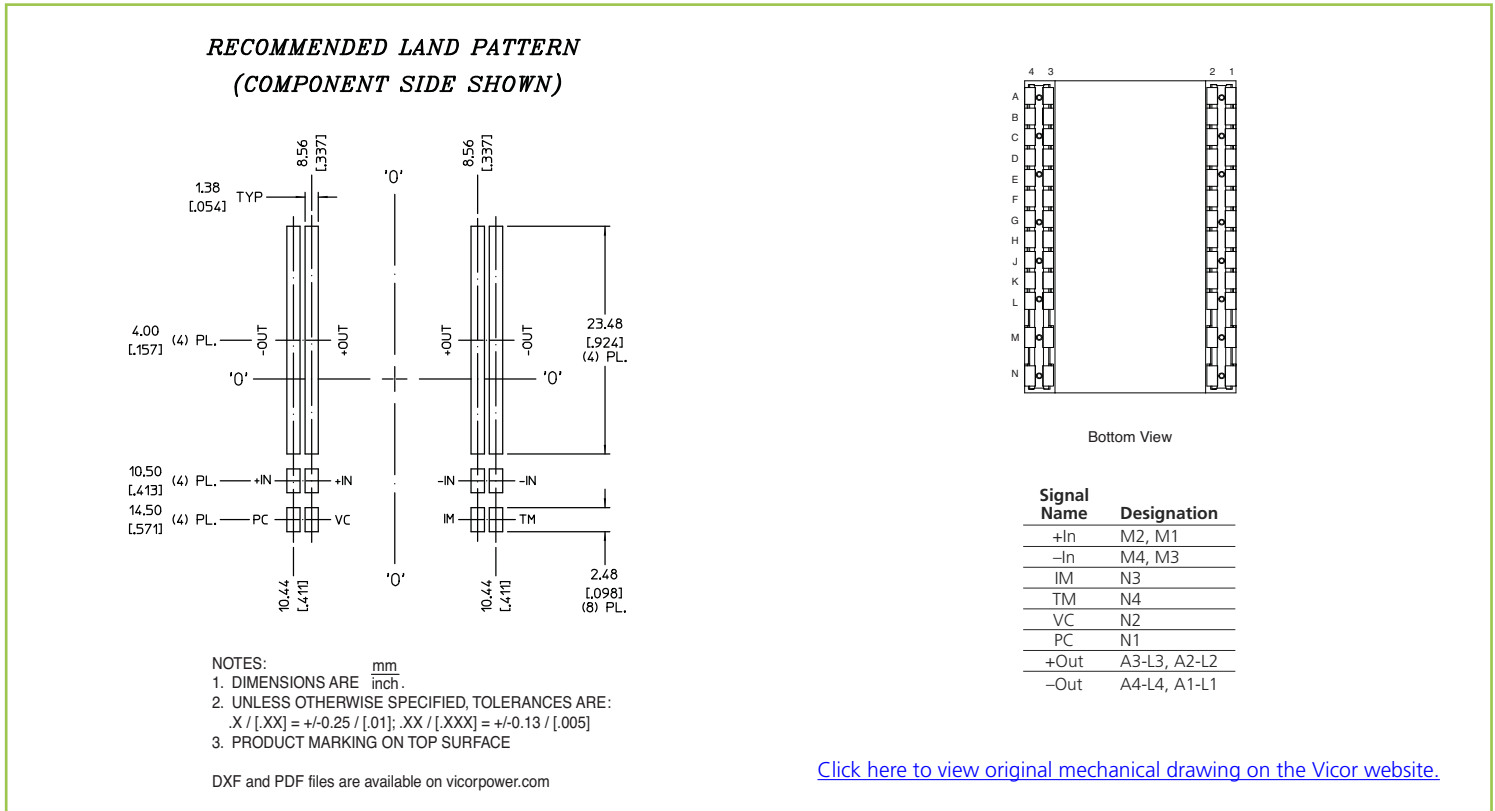

## Warranty

Vicor products are guaranteed for two years from date of shipment against defects in material or workmanship when in normal use and service. This warranty does not extend to products subjected to misuse, accident, or improper application or maintenance. Vicor shall not be liable for collateral or consequential damage. This warranty is extended to the original purchaser only.

EXCEPT FOR THE FOREGOING EXPRESS WARRANTY, VICOR MAKES NO WARRANTY, EXPRESS OR IMPLIED, INCLUDING, BUT NOT LIMITED TO, THE WARRANTY OF MERCHANTABILITY OR FITNESS FOR A PARTICULAR PURPOSE.

Vicor will repair or replace defective products in accordance with its own best judgement. For service under this warranty, the buyer must contact Vicor to obtain a Return Material Authorization (RMA) number and shipping instructions. Products returned without prior authorization will be returned to the buyer. The buyer will pay all charges incurred in returning the product to the factory. Vicor will pay all reshipment charges if the product was defective within the terms of this warranty.

Information published by Vicor has been carefully checked and is believed to be accurate; however, no responsibility is assumed for inaccuracies. Vicor reserves the right to make changes to any products without further notice to improve reliability, function, or design. Vicor does not assume any liability arising out of the application or use of any product or circuit; neither does it convey any license under its patent rights nor the rights of others. Vicor general policy does not recommend the use of its components in life support applications wherein a failure or malfunction may directly threaten life or injury. Per Vicor Terms and Conditions of Sale, the user of Vicor components in life support applications assumes all risks of such use and indemnifies Vicor against all damages.

## **Vicor's comprehensive line of power solutions includes high density AC-DC and DC-DC modules and accessory components, fully configurable AC-DC and DC-DC power supplies, and complete custom power systems.**

Information furnished by Vicor is believed to be accurate and reliable. However, no responsibility is assumed by Vicor for its use. Vicor components are not designed to be used in applications, such as life support systems, wherein a failure or malfunction could result in injury or death. All sales are subject to Vicor's Terms and Conditions of Sale, which are available upon request.

## **Specifications are subject to change without notice.**

## Intellectual Property Notice

Vicor and its subsidiaries own Intellectual Property (including issued U.S. and Foreign Patents and pending patent applications) relating to the products described in this data sheet. Interested parties should contact Vicor's Intellectual Property Department.

The products described on this data sheet are protected by the following U.S. Patents Numbers: 5,945,130; 6,403,009; 6,710,257; 6,911,848; 6,930,893; 6,934,166; 6,940,013; 6,969,909; 7,038,917; 7,145,186; 7,166,898; 7,187,263; 7,202,646; 7,361,844; D496,906; D505,114; D506,438; D509,472; and for use under 6,975,098 and 6,984,965.

**Vicor Corporation**  
25 Frontage Road  
Andover, MA, USA 01810  
Tel: 800-735-6200  
Fax: 978-475-6715

### email

Customer Service: [custserv@vicorpower.com](mailto:custserv@vicorpower.com)  
Technical Support: [apps@vicorpower.com](mailto:apps@vicorpower.com)