



**SANYO Semiconductors**

# DATA SHEET

An ON Semiconductor Company

CMOS LSI

## LC75106V — Digital Echo LSI with Built-in Mic Amplifier

### Overview

The LC75106V is a digital echo LSI for karaoke. It has the microcomputer control mode (I<sup>2</sup>C BUS control) and non-control mode. Therefore, various karaoke systems can be made.

This LSI has 2ch mic amplifier (with ALC), volume of 2ch mic, echo feed back volume and echo volume.

In addition, when the stereo signal internal connected mode has the function of the vocal cancellation etc.

The karaoke system can be constructed with this LSI.

### Functions

- 2ch mic amplifier (with built-in Auto Level Control)
- Volume of 2ch mic
- With built-in for digital echo memory 32kbit
- Feedback volume for digital echo
- Digital echo volume
- Mic mixing function
- Vocal cancellation
- With built-in oscillation circuit
- I<sup>2</sup>C bus control

### Application

- Mini component audio and other

\* I<sup>2</sup>C Bus is a trademark of Philips Corporation.

■ Any and all SANYO Semiconductor Co.,Ltd. products described or contained herein are, with regard to "standard application", intended for the use as general electronics equipment. The products mentioned herein shall not be intended for use for any "special application" (medical equipment whose purpose is to sustain life, aerospace instrument, nuclear control device, burning appliances, transportation machine, traffic signal system, safety equipment etc.) that shall require extremely high level of reliability and can directly threaten human lives in case of failure or malfunction of the product or may cause harm to human bodies, nor shall they grant any guarantee thereof. If you should intend to use our products for new introduction or other application different from current conditions on the usage of automotive device, communication device, office equipment, industrial equipment etc. , please consult with us about usage condition (temperature, operation time etc.) prior to the intended use. If there is no consultation or inquiry before the intended use, our customer shall be solely responsible for the use.

■ Specifications of any and all SANYO Semiconductor Co.,Ltd. products described or contained herein stipulate the performance, characteristics, and functions of the described products in the independent state, and are not guarantees of the performance, characteristics, and functions of the described products as mounted in the customer's products or equipment. To verify symptoms and states that cannot be evaluated in an independent device, the customer should always evaluate and test devices mounted in the customer's products or equipment.

**SANYO Semiconductor Co., Ltd.**

<http://www.sanyosemi.com/en/network/>

# LC75106V

## Specifications

**Absolute Maximum Ratings** at Ta = 25°C, Analog GND = 0V

Parameter	Symbol	Conditions	Ratings	unit
Maximum power supply voltage	V <sub>DD</sub> max	V <sub>DD</sub>	+8.0 to +10.0	V
Allowable consumption power	Pd max	Ta ≤ 70°C *	500	mW
Operating temperature range	Ta		-20 to +70	°C
Storage temperature range	Tstg		-40 to +125	°C

\* Mounted reference PCB (114.3mm × 76.1mm × 1.6mm, glass epoxy resin)

**DC Electrical Characteristics Ratings** at Ta = 25°C, V<sub>SS</sub> = 0V

**Operating Condition**/Ta = 25°C

Parameter	Symbol	Pin name	Conditions	min	typ	max	unit
Recommended supply voltage	V <sub>DD</sub>	V <sub>DD</sub>			9.0		V
Range of operating supply voltage	V <sub>DD</sub> opg	V <sub>DD</sub>	V <sub>DD</sub> =9.0V	8.0		10.0	V

**Electric Characteristics**/Ta = 25°C, V<sub>DD</sub> = 9.0V, fin = 1kHz, V<sub>IN</sub> = 1mVrms = 0dB, R<sub>L</sub> = 10kΩ

Parameter	Symbol	Pin name	Conditions	min	typ	max	unit
Current without signal	I <sub>DDO</sub>	V <sub>DD</sub>				60	mA
Clock frequency	F <sub>CLK</sub>	OSC	OSC Ex.R=30kΩ	1.72	2.45	3.19	MHz
Control data Hi Level voltage	V <sub>IH</sub>	SCL, SDA		2.0		3.5	V
Control data Low Level voltage	V <sub>IL</sub>	SCL, SDA		0.0		0.5	V
Control data Input pulse width	t <sub>φW</sub>	SCL, SDA		1.0			μs
Control data Hold time	t <sub>hold</sub>	SCL, SDA		1.0			μs
Control data Operation frequency	fopg	SCL, SDA				500	kHz

**AC Electrical Characteristics** (Reference data: No measurement)

Parameter	Symbol	Pin name	Conditions	min	typ	max	unit
[Mic-AMP] Input=MICIN1/MICIN2, Output=MICOUT1/MICOUT2, V <sub>IN</sub> =-48dBV, VALC=VREF - 1.414V, Mic-AMP NF Ex.R=680Ω, ALC Ex.C=2.2μF							
Mic Gain	V <sub>GM2</sub>	MICOUT1/2	Mic-AMP NF Ex.R=680Ω	+34.0	+37.0	+42.0	dB
Max output voltage	V <sub>oTM</sub>	MICOUT1/2	Mic Gain=+38dB, THD=1%, Filter=A-filter, ALC=OFF	1.75			Vrms
Total harmonic distortion rate 1	THD <sub>M1</sub>	MICOUT1/2	Mic Gain=+38dB, ALC=OFF, V <sub>O</sub> =-10dBV, Filter=A-filter		0.07	0.5	%
Total harmonic distortion rate 2	THD <sub>M2</sub>	MICOUT1/2	Mic Gain=+38dB, ALC=ON, V <sub>O</sub> =0dBV, V <sub>IN</sub> =-32dBV, Filter=A-filter		0.1	1.0	%
Output noise voltage	V <sub>NOM</sub>	MICOUT1/2	Mic Gain=+38dB, Filter=A-filter		-74.0	-65.0	dBV
ALC attack time	Ta <sub>A</sub>	MICOUT1/2	Mic Gain=+38dB, ALC=ON, V <sub>O</sub> =0dBV, V <sub>IN</sub> =-32dBV		60		ms
ALC release time	Ta <sub>R</sub>	MICOUT1/2	Mic Gain=+38dB, ALC=ON, V <sub>O</sub> =0dBV, V <sub>IN</sub> =-32dBV		6.0		s
Input impedance	Z <sub>IM</sub>	MICIN1/2		45	60	75	kΩ
Output impedance	Z <sub>oM</sub>	MICOUT1/2	Mic-Gain=+38dB, ALC=OFF, V <sub>O</sub> =0dBV	0.75	1.5	3.0	kΩ
[Digital ECHO] Stereo signal outside connection modes, Input=SUMIN, Output=ECHOOUT, V <sub>IN</sub> =-10dBV, Delay Time=100ms, Mic Volume 1/2=0dB, Feedback Volume=-∞							
Delay time	DT	ECHOOUT	F <sub>CLK</sub> =2.45MHz	75	100	125	ms
Output Gain	V <sub>GE</sub>	ECHOOUT		-4.5	-2.0	+0.5	dB
Max output voltage	V <sub>oE</sub>	ECHOOUT	THD=10%, Filter=A-filter	1.5			Vrms
Total harmonic distortion rate	THD <sub>E</sub>	ECHOOUT	Filter=A-filter		0.7	2.0	%
Output noise voltage	V <sub>NOE</sub>	ECHOOUT	Filter=A-filter		-65	-55	dBV
Input impedance	Z <sub>iE</sub>	SUMIN		45	60	75	kΩ
Output impedance	Z <sub>oE</sub>	ECHOOUT	Delay time=100ms, V <sub>O</sub> =0dBV	45	60	75	kΩ

Continued to the next page.

# LC75106V

Continued from the previous page.

Parameter	Symbol	Pin name	Conditions	min	typ	max	unit
[Stereo Line] Stereo signal internal connection modes, Input=LCHIN/RCHIN, Output=LCHOUT/RCHOUT, $V_{IN}=-10\text{dBV}$ , Line Select=Stereo, Mic-Volume 1/2=ECHO Volume= $-\infty$							
Output Gain	$V_{GS}$	Lch/RchOUT		-3.5	-1.5	+0.5	dB
Max output voltage	$V_{oS}$	Lch/RchOUT	THD=1%, Filter=A-filter	1.75			Vrms
Total harmonic distortion rate	$THD_S$	Lch/RchOUT	Filter=A-filter		0.03	0.1	%
Output noise voltage	$V_{NOS}$	Lch/RchOUT	Filter=A-filter		-85.0	-75.0	dBV
Vocal removal rate		Lch/RchOUT		-21.5	-17.5	-14.5	
Input impedance	$Z_{iS}$	Lch/RchIN		75	100	125	k $\Omega$
Output impedance	$Z_{oS}$	Lch/RchOUT	$V_O=0\text{dBV}$	0.75	1.5	3.0	k $\Omega$
[Mic Sum-AMP] Stereo signal outside connection modes, Input=IN1/IN2, Output=SUMOUT, $V_{IN}=-10\text{dBV}$							
Output Gain	$V_{GMS}$	SUMOUT		+4.0	+5.5	+7.0	dB
Max output voltage	$V_{oMS}$	SUMOUT	THD=1%, Filter=A-filter	1.75			Vrms
Total harmonic distortion rate	$THD_{MS}$	SUMOUT	Filter=A-filter		0.05	0.5	%
Output noise voltage	$V_{NOMS}$	SUMOUT	Filter=A-filter		-77.0	-70.0	dBV
Input impedance	$Z_{iMS}$	IN1/IN2		45	60	75	k $\Omega$
Output impedance	$Z_{oMS}$	SUMOUT	$V_O=0\text{dBV}$	1.0	2.0	4.0	k $\Omega$
[ECHO Sum-AMP] Stereo signal outside connection modes, Input=SUMIN/ECHOIN, Output=OUT, $V_{IN}=-10\text{dBV}$							
Output Gain	$V_{GES}$	OUT		+4.0	+5.5	+7.0	dB
Max output voltage	$V_{oES}$	OUT	THD=1%, Filter=A-filter	1.75			Vrms
Total harmonic distortion rate	$THD_{ES}$	OUT	Filter=A-filter		0.05	0.5	%
Output noise voltage	$V_{NOES}$	OUT	Filter=A-filter		-77.0	-70.0	dBV
Input impedance	$Z_{iES}$	SUMIN/ECHOIN		45	60	75	k $\Omega$
Output impedance	$Z_{oES}$	OUT	$V_O=0\text{dBV}$	1.0	2.0	4.0	k $\Omega$

## Package Dimensions

unit:mm (typ)

3247A

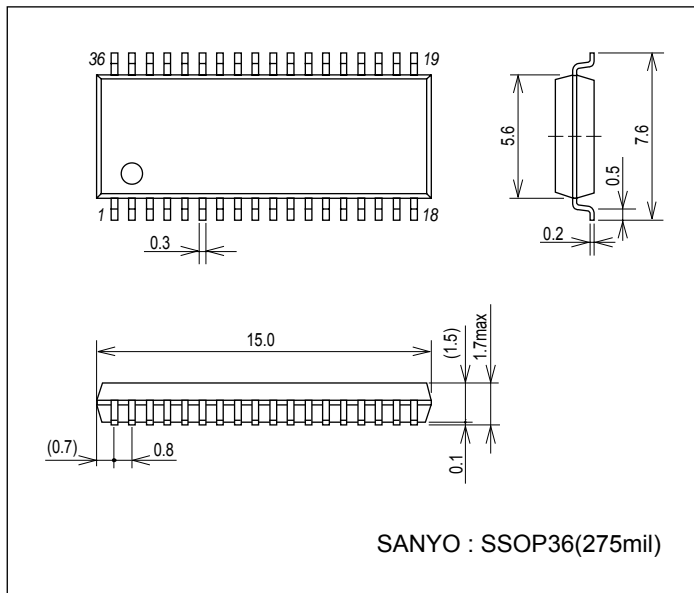

# LC75106V

## Pin Assignment

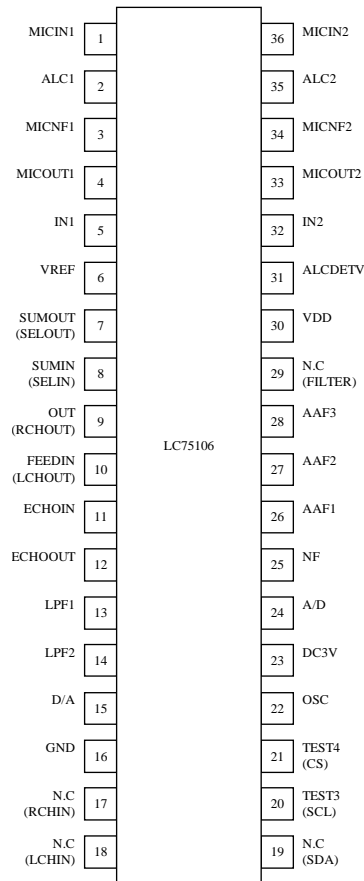

Top view

## Block Diagram

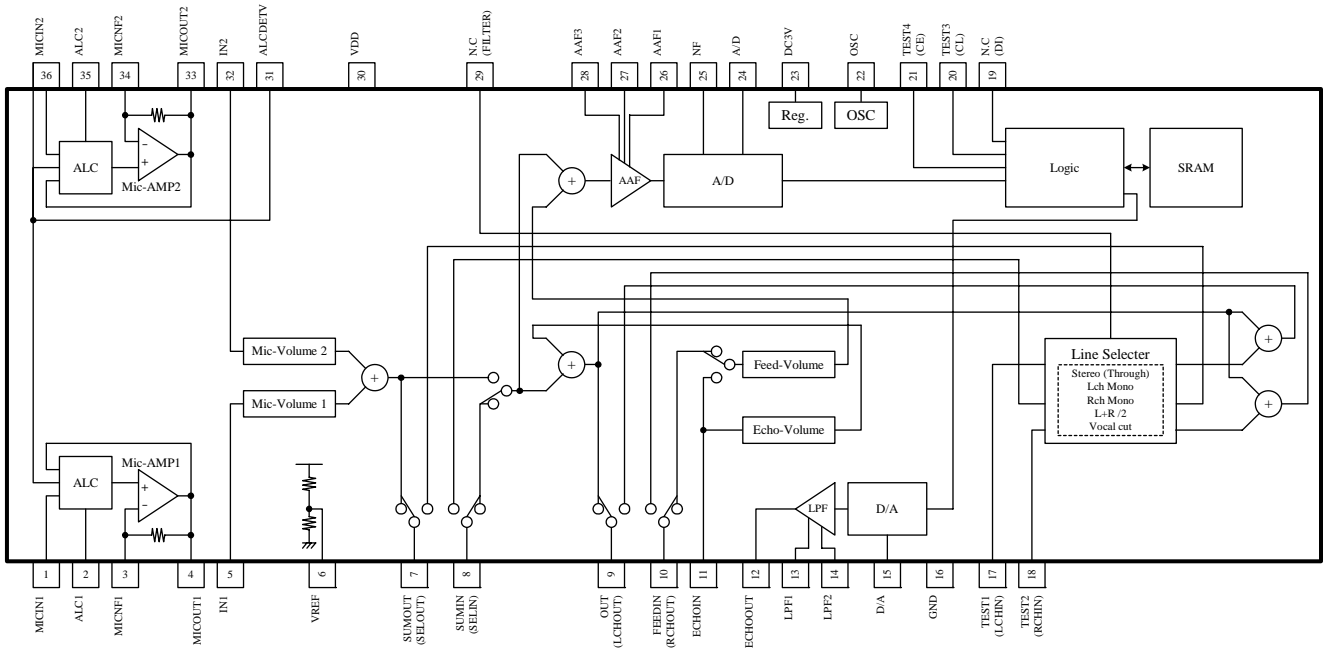

# LC75106V

## Pin Descriptions

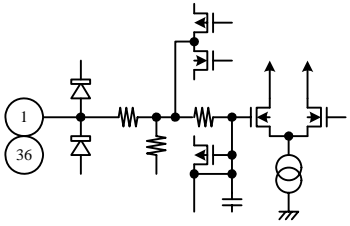
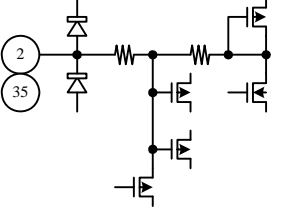
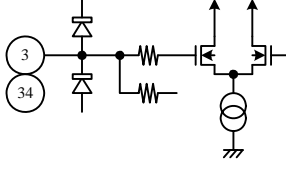
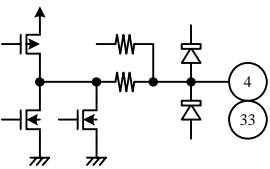
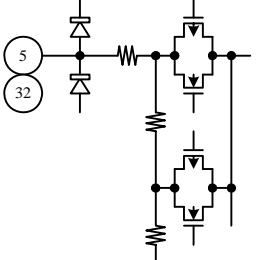
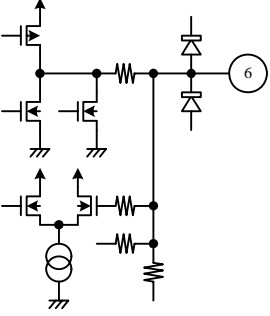
Pin No.	Pin Name	Voltage	Description	Equivalent circuit
1 36	MICIN1 MICIN2	$V_{DD}/2$	Mic signal input 1 Mic signal input 2	
2 35	ALC1 ALC2		Auto level control terminal 1 Auto level control terminal 2	
3 34	MICNF1 MICNF2		Mic feedback signal input terminal 1 Mic feedback signal input terminal 2	
4 33	MICOUT1 MICOUT2		Mic signal output terminal 1 Mic signal output terminal 2	
5 32	IN1 IN2		Mic volume input terminal 1 Mic volume input terminal 2	
6	VREF		Internal standard voltage	

Continued to the next page.

# LC75106V

Continued from the previous page.

Pin No.	Pin Name	Voltage	Description	Equivalent circuit
7	SUMOUT/SELOUT		[CS terminal = "L"] Mic volume 1/2 sum output  [CS terminal = "H"] Selector output terminal	
8	SUMIN/SELIN		[CS terminal = "L"] Delay signal input  [CS terminal = "H"] Selector input terminal	
9	OUT/RCHOUT		[CS terminal = "L"] ECHOIN signal, MICSUM signal sum output  [CS terminal = "H"] Rch output	
10	FEEDIN/LCHOUT		[CS terminal = "L"] Echo feed back signal input  [CS terminal = "H"] Lch output	
11	ECHOIN		Echo signal input (Echo volume input)	
12	ECHOOOUT		Echo signal output	

Continued to the next page.

# LC75106V

Continued from the previous page.

Pin No.	Pin Name	Voltage	Description	Equivalent circuit
13 14	LPF1 LPF2		LPF input terminal 1 LPF input terminal 2	
15 24	D/A A/D		Terminal for A/D Terminal for D/A	
16	GND		Analog GND	
17 18	NC/RCHIN NC/LCHIN		Rch input terminal Lch input terminal	
19	SDA	0V/3.3V	I <sup>2</sup> C bus SDA terminal	
20 21	SCL CS	0V/3.3V	I <sup>2</sup> C bus SCL terminal MODE select terminal	
22	OSC		Oscillator circuit adjustment terminal	

Continued to the next page.

# LC75106V

Continued from the previous page.

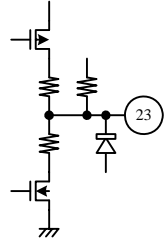
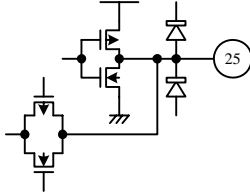
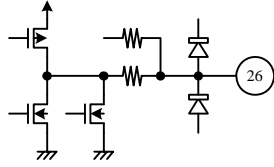
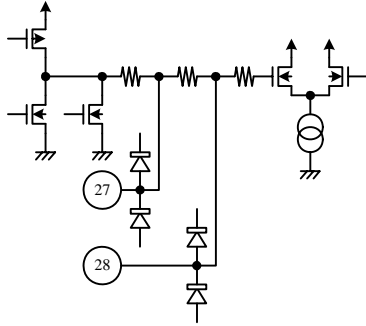
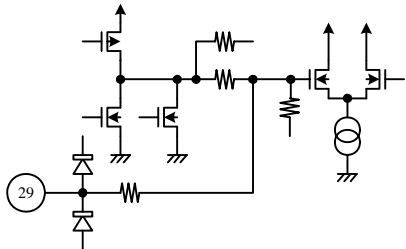
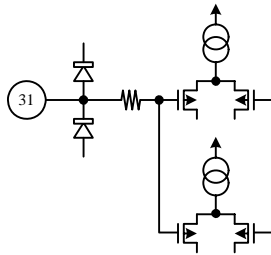
Pin No.	Pin Name	Voltage	Description	Equivalent circuit
23	DC3V	3.3V	Power source for logic block	
25	NF		Terminal for A/D	
26	AAF1		AAF input terminal 1	
27 28	AAF2 AAF3		AAF input terminal 2 AAF input terminal 3	
29	NC/FILTER		Filter input terminal	
30	V <sub>DD</sub>		Supply voltage	
31	ALCDETV		ALC setting voltage input terminal	



# LC75106V

## Sample Application Circuit (Mic-Gain = +38dB)

Stereo signal internal connection modes

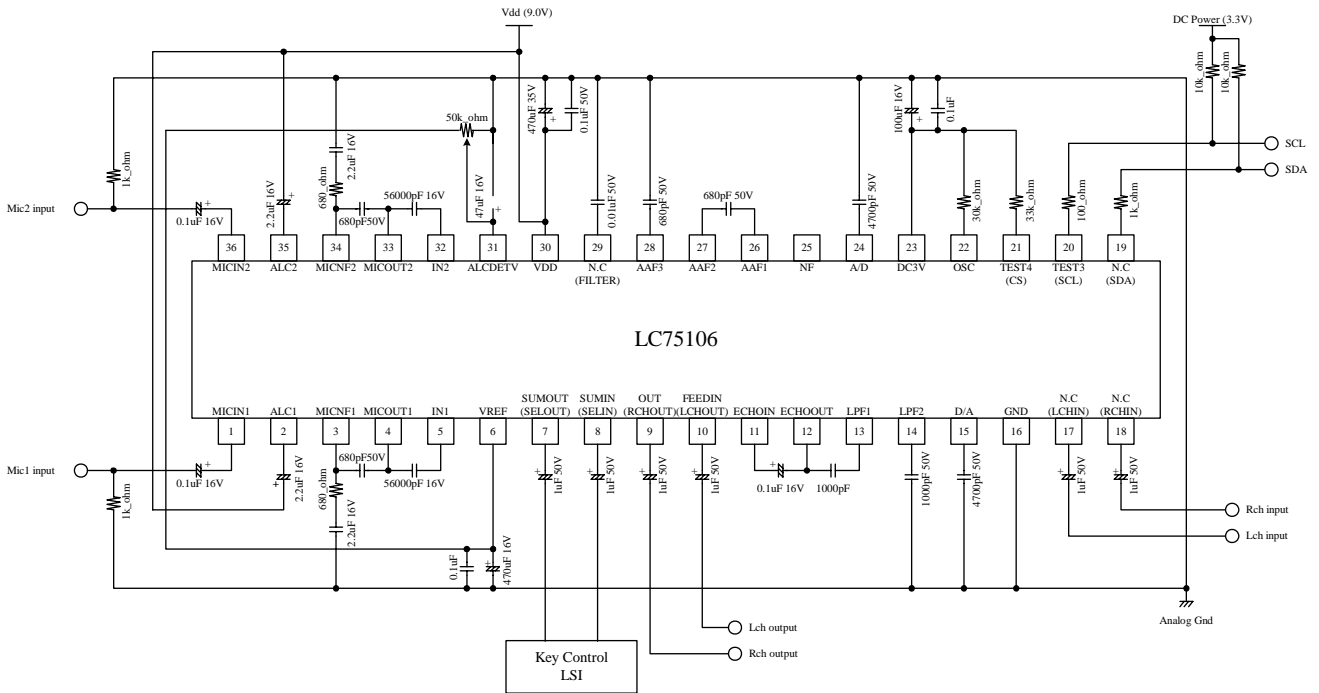

Stereo signal outside connection modes

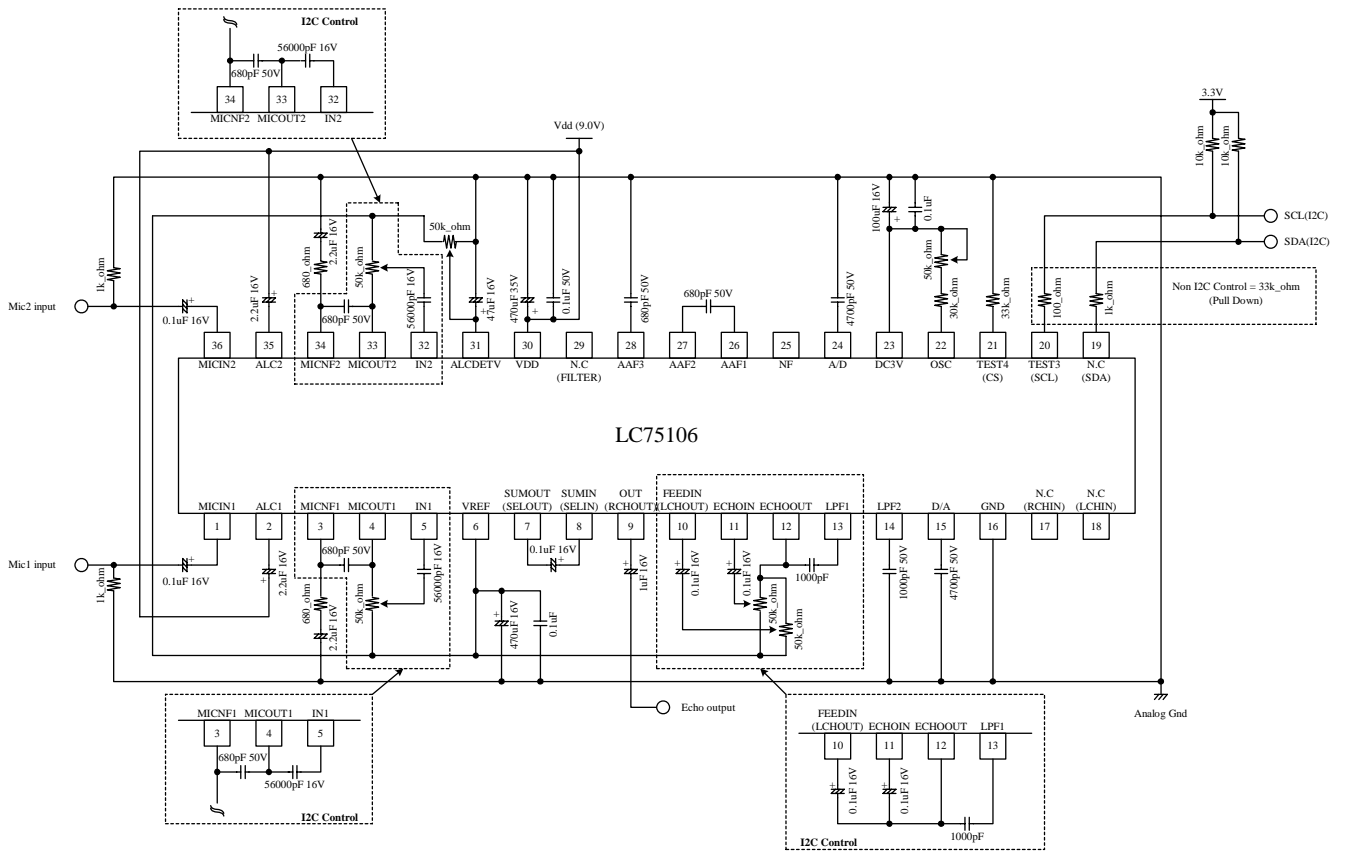

# LC75106V

## Control Data Structure (Serial Data Input)

The setting of LC75106 can be controlled with I<sup>2</sup>C Bus.

All the settings can be controlled by I<sup>2</sup>C Bus at the stereo signal internal connection modes (CS terminal = "H"), and all the volumes except the stereo source control can be set at the stereo signal outside connection modes (CS terminal = "L").

The karaoke system can be made from external resistance by doing I<sup>2</sup>C Bus Line in Pull Up at the stereo signal outside connection modes.

### 1) The explanation of I<sup>2</sup>C Bus

I<sup>2</sup>C Bus (Inter IC Bus) is the bus system which the PHILIPS company developed.

It does controls such as the start, the stop by two control signals of SDA (Serial Data) and SCL (Serial Clock).

The output of each signal is open drain and forms out of wired OR.

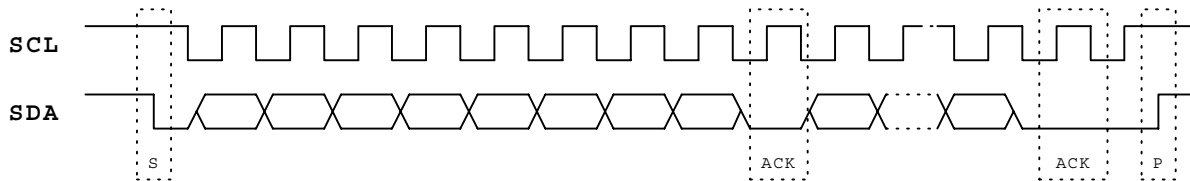

S; Start condition/P; Stop condition/ACK; Acknowledge

Data is transmitted in the MSB first.

1 unit is composed of 8 bits and ACK is put back from the slave to confirm.

Slave IC reads data with rising edge of SCL.

Master IC changes data by falling edge in SCL.

### 2) The control register

Table1 Slave Address

MSB							LSB
0	0	1	1	1	0	0	0

Note; LC75106 is reception exclusive use. It depends and it uses LSB by the "0" fixation.

### • I<sup>2</sup>C data

Function	Sub Address		Data							
	BINARY	HEX	D7	D6	D5	D4	D3	D2	D1	D0
Stereo line select/Mic1 volume	0000 0001	01	LD2	LD1	LD0	KEY	M1D3	M1D2	M1D1	M1D0
Mic2 volume/Test	0000 0010	02	M2D3	M2D2	M2D1	M2D0	TEST3	TEST2	TEST1	TEST0
Delay time/ECHO volume	0000 0011	03	0	DT2	DT1	DT0	0	ED2	ED1	ED0
Feed back volume	0000 0100	04	0	FB2	FB1	FB0	0	0	0	0

# LC75106V

## Control Data Description

No	Control Part/ Data	Description	Related Data																																																																																										
(1)	Line select LD2 LD1 LD0	<p>•The data determines line output.</p> <table border="1" style="width: 100%; border-collapse: collapse; margin-left: 20px;"> <thead> <tr> <th style="width: 10%;">LD2</th> <th style="width: 10%;">LD1</th> <th style="width: 10%;">LD0</th> <th style="width: 70%;"></th> </tr> </thead> <tbody> <tr> <td style="text-align: center;">0</td> <td style="text-align: center;">0</td> <td style="text-align: center;">0</td> <td>Stereo output (Initial setting)</td> </tr> <tr> <td style="text-align: center;">0</td> <td style="text-align: center;">0</td> <td style="text-align: center;">1</td> <td>Lch Mono output</td> </tr> <tr> <td style="text-align: center;">0</td> <td style="text-align: center;">1</td> <td style="text-align: center;">0</td> <td>Rch Mono output</td> </tr> <tr> <td style="text-align: center;">0</td> <td style="text-align: center;">1</td> <td style="text-align: center;">1</td> <td>L+R/2 output</td> </tr> <tr> <td style="text-align: center;">1</td> <td style="text-align: center;">0</td> <td style="text-align: center;">0</td> <td>Vocal cut output</td> </tr> <tr> <td style="text-align: center;">1</td> <td style="text-align: center;">0</td> <td style="text-align: center;">1</td> <td>Reserve</td> </tr> <tr> <td style="text-align: center;">1</td> <td style="text-align: center;">1</td> <td style="text-align: center;">0</td> <td>Reserve</td> </tr> <tr> <td style="text-align: center;">1</td> <td style="text-align: center;">1</td> <td style="text-align: center;">1</td> <td>Reserve</td> </tr> </tbody> </table>	LD2	LD1	LD0		0	0	0	Stereo output (Initial setting)	0	0	1	Lch Mono output	0	1	0	Rch Mono output	0	1	1	L+R/2 output	1	0	0	Vocal cut output	1	0	1	Reserve	1	1	0	Reserve	1	1	1	Reserve	CS="H"																																																						
LD2	LD1	LD0																																																																																											
0	0	0	Stereo output (Initial setting)																																																																																										
0	0	1	Lch Mono output																																																																																										
0	1	0	Rch Mono output																																																																																										
0	1	1	L+R/2 output																																																																																										
1	0	0	Vocal cut output																																																																																										
1	0	1	Reserve																																																																																										
1	1	0	Reserve																																																																																										
1	1	1	Reserve																																																																																										
(2)	External key control switching data key	<p>•This data determines route where external key control is used.</p> <table border="1" style="width: 100%; border-collapse: collapse; margin-left: 20px;"> <thead> <tr> <th style="width: 10%;">KEY</th> <th style="width: 90%;">External key control</th> </tr> </thead> <tbody> <tr> <td style="text-align: center;">0</td> <td>Invalid (Initial setting)</td> </tr> <tr> <td style="text-align: center;">1</td> <td>valid</td> </tr> </tbody> </table>	KEY	External key control	0	Invalid (Initial setting)	1	valid	CS="H"																																																																																				
KEY	External key control																																																																																												
0	Invalid (Initial setting)																																																																																												
1	valid																																																																																												
(3)	Microphone volume gain setting data M1D3 M1D2 M1D1 M1D0 M2D3 M2D2 M2D1 M2D0	<p>•The data determines the gain of MICIN 1/2.</p> <table border="1" style="width: 100%; border-collapse: collapse; margin-left: 20px;"> <thead> <tr> <th style="width: 10%;">M1D3</th> <th style="width: 10%;">M1D2</th> <th style="width: 10%;">M1D1</th> <th style="width: 10%;">M1D0</th> <th style="width: 60%;"></th> </tr> <tr> <th style="width: 10%;">M2D3</th> <th style="width: 10%;">M2D2</th> <th style="width: 10%;">M2D1</th> <th style="width: 10%;">M2D0</th> <th></th> </tr> </thead> <tbody> <tr> <td style="text-align: center;">0</td> <td style="text-align: center;">0</td> <td style="text-align: center;">0</td> <td style="text-align: center;">0</td> <td>0dB (Initial setting)</td> </tr> <tr> <td style="text-align: center;">0</td> <td style="text-align: center;">0</td> <td style="text-align: center;">0</td> <td style="text-align: center;">1</td> <td>-2dB</td> </tr> <tr> <td style="text-align: center;">0</td> <td style="text-align: center;">0</td> <td style="text-align: center;">1</td> <td style="text-align: center;">0</td> <td>-4dB</td> </tr> <tr> <td style="text-align: center;">0</td> <td style="text-align: center;">0</td> <td style="text-align: center;">1</td> <td style="text-align: center;">1</td> <td>-6dB</td> </tr> <tr> <td style="text-align: center;">0</td> <td style="text-align: center;">1</td> <td style="text-align: center;">0</td> <td style="text-align: center;">0</td> <td>-8dB</td> </tr> <tr> <td style="text-align: center;">0</td> <td style="text-align: center;">1</td> <td style="text-align: center;">0</td> <td style="text-align: center;">1</td> <td>-10dB</td> </tr> <tr> <td style="text-align: center;">0</td> <td style="text-align: center;">1</td> <td style="text-align: center;">1</td> <td style="text-align: center;">0</td> <td>-12dB</td> </tr> <tr> <td style="text-align: center;">0</td> <td style="text-align: center;">1</td> <td style="text-align: center;">1</td> <td style="text-align: center;">1</td> <td>-14dB</td> </tr> <tr> <td style="text-align: center;">1</td> <td style="text-align: center;">0</td> <td style="text-align: center;">0</td> <td style="text-align: center;">0</td> <td>-16dB</td> </tr> <tr> <td style="text-align: center;">1</td> <td style="text-align: center;">0</td> <td style="text-align: center;">0</td> <td style="text-align: center;">1</td> <td>-18dB</td> </tr> <tr> <td style="text-align: center;">1</td> <td style="text-align: center;">0</td> <td style="text-align: center;">1</td> <td style="text-align: center;">0</td> <td>-20dB</td> </tr> <tr> <td style="text-align: center;">1</td> <td style="text-align: center;">0</td> <td style="text-align: center;">1</td> <td style="text-align: center;">1</td> <td>-23dB</td> </tr> <tr> <td style="text-align: center;">1</td> <td style="text-align: center;">1</td> <td style="text-align: center;">0</td> <td style="text-align: center;">0</td> <td>-26dB</td> </tr> <tr> <td style="text-align: center;">1</td> <td style="text-align: center;">1</td> <td style="text-align: center;">0</td> <td style="text-align: center;">1</td> <td>-29dB</td> </tr> <tr> <td style="text-align: center;">1</td> <td style="text-align: center;">1</td> <td style="text-align: center;">1</td> <td style="text-align: center;">0</td> <td>-32dB</td> </tr> <tr> <td style="text-align: center;">1</td> <td style="text-align: center;">1</td> <td style="text-align: center;">1</td> <td style="text-align: center;">1</td> <td>-∞</td> </tr> </tbody> </table>	M1D3	M1D2	M1D1	M1D0		M2D3	M2D2	M2D1	M2D0		0	0	0	0	0dB (Initial setting)	0	0	0	1	-2dB	0	0	1	0	-4dB	0	0	1	1	-6dB	0	1	0	0	-8dB	0	1	0	1	-10dB	0	1	1	0	-12dB	0	1	1	1	-14dB	1	0	0	0	-16dB	1	0	0	1	-18dB	1	0	1	0	-20dB	1	0	1	1	-23dB	1	1	0	0	-26dB	1	1	0	1	-29dB	1	1	1	0	-32dB	1	1	1	1	-∞	
M1D3	M1D2	M1D1	M1D0																																																																																										
M2D3	M2D2	M2D1	M2D0																																																																																										
0	0	0	0	0dB (Initial setting)																																																																																									
0	0	0	1	-2dB																																																																																									
0	0	1	0	-4dB																																																																																									
0	0	1	1	-6dB																																																																																									
0	1	0	0	-8dB																																																																																									
0	1	0	1	-10dB																																																																																									
0	1	1	0	-12dB																																																																																									
0	1	1	1	-14dB																																																																																									
1	0	0	0	-16dB																																																																																									
1	0	0	1	-18dB																																																																																									
1	0	1	0	-20dB																																																																																									
1	0	1	1	-23dB																																																																																									
1	1	0	0	-26dB																																																																																									
1	1	0	1	-29dB																																																																																									
1	1	1	0	-32dB																																																																																									
1	1	1	1	-∞																																																																																									
(4)	Delay time setting data DT2 DT1 DT0	<p>•The data determines delay time for echo.</p> <table border="1" style="width: 100%; border-collapse: collapse; margin-left: 20px;"> <thead> <tr> <th style="width: 10%;">DT2</th> <th style="width: 10%;">DT1</th> <th style="width: 10%;">DT0</th> <th style="width: 70%;"></th> </tr> </thead> <tbody> <tr> <td style="text-align: center;">0</td> <td style="text-align: center;">0</td> <td style="text-align: center;">0</td> <td>OFF</td> </tr> <tr> <td style="text-align: center;">0</td> <td style="text-align: center;">0</td> <td style="text-align: center;">1</td> <td>75ms (Initial setting)</td> </tr> <tr> <td style="text-align: center;">0</td> <td style="text-align: center;">1</td> <td style="text-align: center;">0</td> <td>100ms</td> </tr> <tr> <td style="text-align: center;">0</td> <td style="text-align: center;">1</td> <td style="text-align: center;">1</td> <td>125ms</td> </tr> <tr> <td style="text-align: center;">1</td> <td style="text-align: center;">0</td> <td style="text-align: center;">0</td> <td>150ms</td> </tr> <tr> <td style="text-align: center;">1</td> <td style="text-align: center;">0</td> <td style="text-align: center;">1</td> <td>175ms</td> </tr> <tr> <td style="text-align: center;">1</td> <td style="text-align: center;">1</td> <td style="text-align: center;">0</td> <td>200ms</td> </tr> <tr> <td style="text-align: center;">1</td> <td style="text-align: center;">1</td> <td style="text-align: center;">1</td> <td>Reserve</td> </tr> </tbody> </table>	DT2	DT1	DT0		0	0	0	OFF	0	0	1	75ms (Initial setting)	0	1	0	100ms	0	1	1	125ms	1	0	0	150ms	1	0	1	175ms	1	1	0	200ms	1	1	1	Reserve																																																							
DT2	DT1	DT0																																																																																											
0	0	0	OFF																																																																																										
0	0	1	75ms (Initial setting)																																																																																										
0	1	0	100ms																																																																																										
0	1	1	125ms																																																																																										
1	0	0	150ms																																																																																										
1	0	1	175ms																																																																																										
1	1	0	200ms																																																																																										
1	1	1	Reserve																																																																																										

Continued to the next page.

# LC75106V

Continued from the previous page.

No	Control Part/ Data	Description	Related Data																																				
(5)	Echo volume gain setting data ED2 ED1 ED0	<p>•The data determines gain of echo output.</p> <table border="1" style="margin-left: auto; margin-right: auto; border-collapse: collapse;"> <thead> <tr> <th style="width: 10%;">ED2</th> <th style="width: 10%;">ED1</th> <th style="width: 10%;">ED0</th> <th style="width: 70%;"></th> </tr> </thead> <tbody> <tr> <td style="text-align: center;">0</td> <td style="text-align: center;">0</td> <td style="text-align: center;">0</td> <td>0dB (Initial setting)</td> </tr> <tr> <td style="text-align: center;">0</td> <td style="text-align: center;">0</td> <td style="text-align: center;">1</td> <td>-2dB</td> </tr> <tr> <td style="text-align: center;">0</td> <td style="text-align: center;">1</td> <td style="text-align: center;">0</td> <td>-4dB</td> </tr> <tr> <td style="text-align: center;">0</td> <td style="text-align: center;">1</td> <td style="text-align: center;">1</td> <td>-6dB</td> </tr> <tr> <td style="text-align: center;">1</td> <td style="text-align: center;">0</td> <td style="text-align: center;">0</td> <td>-9dB</td> </tr> <tr> <td style="text-align: center;">1</td> <td style="text-align: center;">0</td> <td style="text-align: center;">1</td> <td>-12dB</td> </tr> <tr> <td style="text-align: center;">1</td> <td style="text-align: center;">1</td> <td style="text-align: center;">0</td> <td>-15dB</td> </tr> <tr> <td style="text-align: center;">1</td> <td style="text-align: center;">1</td> <td style="text-align: center;">1</td> <td>-∞</td> </tr> </tbody> </table>	ED2	ED1	ED0		0	0	0	0dB (Initial setting)	0	0	1	-2dB	0	1	0	-4dB	0	1	1	-6dB	1	0	0	-9dB	1	0	1	-12dB	1	1	0	-15dB	1	1	1	-∞	
ED2	ED1	ED0																																					
0	0	0	0dB (Initial setting)																																				
0	0	1	-2dB																																				
0	1	0	-4dB																																				
0	1	1	-6dB																																				
1	0	0	-9dB																																				
1	0	1	-12dB																																				
1	1	0	-15dB																																				
1	1	1	-∞																																				
(6)	Feedback volume gain setting data FB2 FB1 FB0	<p>•The data determines feedback volume for echo.</p> <table border="1" style="margin-left: auto; margin-right: auto; border-collapse: collapse;"> <thead> <tr> <th style="width: 10%;">FB2</th> <th style="width: 10%;">FB1</th> <th style="width: 10%;">FB0</th> <th style="width: 70%;"></th> </tr> </thead> <tbody> <tr> <td style="text-align: center;">0</td> <td style="text-align: center;">0</td> <td style="text-align: center;">0</td> <td>-4dB (Initial setting)</td> </tr> <tr> <td style="text-align: center;">0</td> <td style="text-align: center;">0</td> <td style="text-align: center;">1</td> <td>-6dB</td> </tr> <tr> <td style="text-align: center;">0</td> <td style="text-align: center;">1</td> <td style="text-align: center;">0</td> <td>-9dB</td> </tr> <tr> <td style="text-align: center;">0</td> <td style="text-align: center;">1</td> <td style="text-align: center;">1</td> <td>-12dB</td> </tr> <tr> <td style="text-align: center;">1</td> <td style="text-align: center;">0</td> <td style="text-align: center;">0</td> <td>-∞</td> </tr> <tr> <td style="text-align: center;">1</td> <td style="text-align: center;">0</td> <td style="text-align: center;">1</td> <td>Reserve</td> </tr> <tr> <td style="text-align: center;">1</td> <td style="text-align: center;">1</td> <td style="text-align: center;">0</td> <td>Reserve</td> </tr> <tr> <td style="text-align: center;">1</td> <td style="text-align: center;">1</td> <td style="text-align: center;">1</td> <td>Reserve</td> </tr> </tbody> </table>	FB2	FB1	FB0		0	0	0	-4dB (Initial setting)	0	0	1	-6dB	0	1	0	-9dB	0	1	1	-12dB	1	0	0	-∞	1	0	1	Reserve	1	1	0	Reserve	1	1	1	Reserve	
FB2	FB1	FB0																																					
0	0	0	-4dB (Initial setting)																																				
0	0	1	-6dB																																				
0	1	0	-9dB																																				
0	1	1	-12dB																																				
1	0	0	-∞																																				
1	0	1	Reserve																																				
1	1	0	Reserve																																				
1	1	1	Reserve																																				
(7)	LSI test data TEST3 TEST2 TEST1 TEST0	<p>•Data for LSI testing</p> <p>TEST3 to TEST0 should be set to "0".</p>																																					

# LC75106V

## Control with external parts

LC75106 can adjust the setting with external parts at the stereo signal outside connection modes.

### (1) Delay time setting

The Delay time changes if the CR oscillation frequency with built-in LC75106 is adjusted.

Delay time	external Resistance	OSC Freq	Note
75ms	30kΩ	2.458MHz	
100ms	47kΩ	1.843MHz	
120ms	56kΩ	1.536MHz	
150ms	75kΩ	1.228MHz	
190ms	187kΩ	0.970MHz	

### (2) Mic-Volume/ECHO Volume setting

When Mic Volume and ECHO Volume are set with external parts, it is possible to set it in the ratio of R1 and R2 as shown in the figure below.

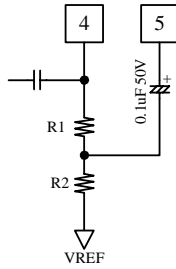

Gain	R1	R2	Note
-2dB	10.284kΩ	39.716kΩ	
-4dB	18.452kΩ	31.548kΩ	
-6dB	24.941kΩ	25.059kΩ	
-8dB	30.095kΩ	19.905kΩ	
-9dB	32.259kΩ	17.741kΩ	
-10dB	34.189kΩ	15.811kΩ	
-12dB	37.441kΩ	12.559kΩ	
-14dB	40.024kΩ	9.976kΩ	
-15dB	41.109kΩ	8.891kΩ	
-16dB	42.076kΩ	7.924kΩ	
-18dB	43.705kΩ	6.295kΩ	
-20dB	45.000kΩ	5.000kΩ	
-23dB	46.460kΩ	3.540kΩ	
-26dB	47.494kΩ	2.506kΩ	
-29dB	48.226kΩ	1.774kΩ	
-32dB	48.744kΩ	1.256kΩ	
-∞dB	50.000kΩ	0	

### (3) Feed Back Volume setting

To prevent the oscillation, the Echo Feed Back signal input terminal has Gain of -4dB.

Therefore, please calculate in consideration of the attenuation of -4dB when you set Volume.

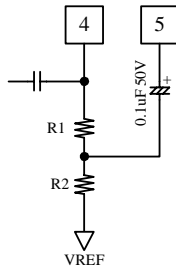

Gain	R1	R2	Note
-4dB	0	50.000kΩ	
-6dB	10.284kΩ	39.716kΩ	
-9dB	18.452kΩ	31.548kΩ	
-12dB	24.941kΩ	25.059kΩ	
-∞dB	50.000kΩ	0	

(4) Mic AMP Gain setting

Mic Amplifier Gain is adjusted according to the resistance value applied to 3pin and 34pin. And low frequency is cut off by connecting condenser.

Mic Amplifier has built-in ALC (Auto Level Control). Output level can be controlled by inputting the standard voltage to 31pin.

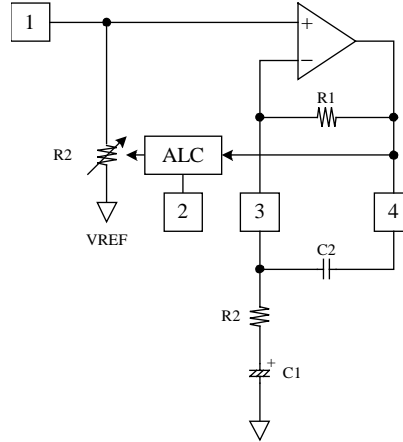

1) Mic AMP Gain setting

- R1 = 56.2kΩ  
[Mic Gain = 38dB]  
R2 = R1/Mic Gain  
= 56.2k/79.4  
≈ 680

2) fc setting

$$f_c = \frac{1}{2\pi R_1 C_1}$$

(5) ALC control voltage setting

1) ALC control voltage setting

When the ALC detecting voltage is input to 31pin, the ALC operation level can be set.

The setting method becomes as follows.

[VDD = 9.0V/1Vrms setting]

$$V_{DD}/2 = 9.0/2 = 4.5$$

$$1V_{rms}/2 = \sqrt{2} * 1 = 1.414V$$

$$VALC \text{ setting voltage} = 4.5 - 1.414 = 3.086V \text{ (DC)}$$

ALC setting voltage can be set to put resistance between the terminal VREF and the terminal GND.

\* The voltage of the terminal VREF depends on the power-supply voltage and changes.

2) ALC attack time/release time setting

The attack time and the release time of ALC can be set with the capacitor between 2pin - VDD and 35pin - VDD.

capacitor	Attack time	Release time	Note
2.2μF	About 60ms	About 6.0s	
1.0μF	About 35ms	About 2.5s	
0.1μF	About 16ms	About 0.25s	

- SANYO Semiconductor Co.,Ltd. assumes no responsibility for equipment failures that result from using products at values that exceed, even momentarily, rated values (such as maximum ratings, operating condition ranges, or other parameters) listed in products specifications of any and all SANYO Semiconductor Co.,Ltd. products described or contained herein.
- Regarding monolithic semiconductors, if you should intend to use this IC continuously under high temperature, high current, high voltage, or drastic temperature change, even if it is used within the range of absolute maximum ratings or operating conditions, there is a possibility of decrease reliability. Please contact us for a confirmation.
- SANYO Semiconductor Co.,Ltd. strives to supply high-quality high-reliability products, however, any and all semiconductor products fail or malfunction with some probability. It is possible that these probabilistic failures or malfunction could give rise to accidents or events that could endanger human lives, trouble that could give rise to smoke or fire, or accidents that could cause damage to other property. When designing equipment, adopt safety measures so that these kinds of accidents or events cannot occur. Such measures include but are not limited to protective circuits and error prevention circuits for safe design, redundant design, and structural design.
- In the event that any or all SANYO Semiconductor Co.,Ltd. products described or contained herein are controlled under any of applicable local export control laws and regulations, such products may require the export license from the authorities concerned in accordance with the above law.
- No part of this publication may be reproduced or transmitted in any form or by any means, electronic or mechanical, including photocopying and recording, or any information storage or retrieval system, or otherwise, without the prior written consent of SANYO Semiconductor Co.,Ltd.
- Any and all information described or contained herein are subject to change without notice due to product/technology improvement, etc. When designing equipment, refer to the "Delivery Specification" for the SANYO Semiconductor Co.,Ltd. product that you intend to use.
- Upon using the technical information or products described herein, neither warranty nor license shall be granted with regard to intellectual property rights or any other rights of SANYO Semiconductor Co.,Ltd. or any third party. SANYO Semiconductor Co.,Ltd. shall not be liable for any claim or suits with regard to a third party's intellectual property rights which has resulted from the use of the technical information and products mentioned above.

This catalog provides information as of November, 2012. Specifications and information herein are subject to change without notice.