



## MPSA05/55

## AMPLIFIER TRANSISTOR

NPN MPSA05

PNP MPSA55

### ■ FEATURES

\* Collector-Emitter Voltage:  $V_{CE0}=60V$

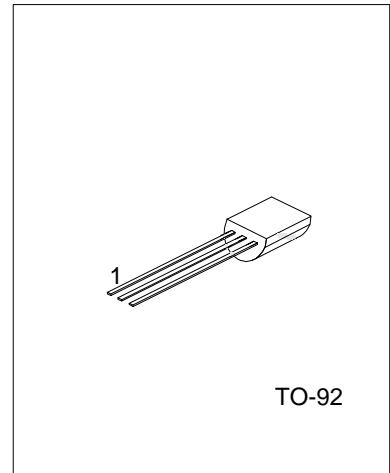

### ■ ORDERING INFORMATION

Ordering Number			Package	Pin Assignment			Packing
Normal	Lead Free	Halogen Free		1	2	3	
MPSA05-T92-B	MPSA05L-T92-B	MPSA05G-T92-B	TO-92	E	B	C	Tape Box
MPSA05-T92-K	MPSA05L-T92-K	MPSA05G-T92-K	TO-92	E	B	C	Bulk
MPSA55-T92-B	MPSA55L-T92-B	MPSA55G-T92-B	TO-92	E	B	C	Tape Box
MPSA55-T92-K	MPSA55L-T92-K	MPSA55G-T92-K	TO-92	E	B	C	Bulk

Note: Pin assignment: E: EMITTER, C: COLLECTOR, B: BASE

<p>MPSA05L-T92-B</p> <p>(1)Packing Type</p> <p>(2)Package Type</p> <p>(3)Lead Free</p>	<p>(1) B: Tape Box, K: Bulk</p> <p>(2) T92: TO-92</p> <p>(3) G: Halogen Free, L: Lead Free, Blank: Pb/Sn</p>
--	--

■ ABSOLUTE MAXIMUM RATING ( $T_A=25^\circ\text{C}$ , unless otherwise specified)

PARAMETER	SYMBOL	RATINGS	UNIT
Collector-base voltage	$V_{CBO}$	60	V
Collector-emitter voltage	$V_{CEO}$	60	V
Emitter-base voltage	$V_{EBO}$	4	V
Collector current - Continuous	$I_C$	500	mA
Total device dissipation, @ $T_A=25^\circ\text{C}$ Derate above $25^\circ\text{C}$	$P_D$	625 5	mW mW/ $^\circ\text{C}$
Total device dissipation, @ $T_C=25^\circ\text{C}$ Derate above $25^\circ\text{C}$	$P_D$	1500 12	mW mW/ $^\circ\text{C}$
Junction Temperature	$T_J$	125	$^\circ\text{C}$
Storage Temperature	$T_{STG}$	-40 ~ +150	$^\circ\text{C}$

Note: 1. Absolute maximum ratings are those values beyond which the device could be permanently damaged.  
Absolute maximum ratings are stress ratings only and functional device operation is not implied.

■ THERMAL DATA

PARAMETER	SYMBOL	RATINGS	UNIT
Thermal resistance, junction to ambient (Note)	$R_{\theta JA}$	200	$^\circ\text{C}/\text{W}$
Thermal resistance, junction to case	$R_{\theta JC}$	83.3	$^\circ\text{C}/\text{W}$

Note:  $R_{\theta JA}$  is measured with the device soldered into a typical printed circuit board.

■ ELECTRICAL CHARACTERISTICS ( $T_a=25^\circ\text{C}$ , unless otherwise specified)

PARAMETER	SYMBOL	TEST CONDITIONS	MIN	TYP	MAX	UNIT
<b>OFF CHARACTERISTICS</b>						
Collector-emitter breakdown voltage (note 1)	$V_{(BR)CEO}$	$I_C=1.0\text{mA}, I_B=0$	60			V
Emitter-base breakdown voltage	$V_{(BR)EBO}$	$I_E=100\mu\text{A}, I_C=0$	4			V
Collector cutoff current	$I_{CES}$	$V_{CE}=60\text{V}, I_B=0$			0.1	$\mu\text{A}$
Collector cutoff current	$I_{CBO}$	$V_{CB}=60\text{V}, I_E=0$			0.1	$\mu\text{A}$
<b>ON CHARACTERISTICS</b>						
DC current gain	$h_{FE}$	$I_C=10\text{mA}, V_{CE}=1\text{V}$ $I_C=100\text{mA}, V_{CE}=1\text{V}$	100 100			
Collector-emitter saturation voltage	$V_{CE(SAT)}$	$I_C=100\text{mA}, I_B=10\text{mA}$			0.25	V
Base-emitter on voltage	$V_{BE(ON)}$	$I_C=100\text{mA}, V_{CE}=1\text{V}$			1.2	V
<b>SMALL-SIGNAL CHARACTERISTICS</b>						
Current gain bandwidth product (note 2)	MPSA05	$f_T$	$I_C=10\text{mA}, V_{CE}=2\text{V}, f=100\text{MHz}$	100		MHz
	MPSA55					

Note 1. Pulse test:  $PW \leq 300\mu\text{s}$ , Duty Cycle  $\leq 2\%$

2.  $f_T$  is defined as the frequency at which  $I_{hfe}$  extrapolates to unity.

■ SWITCHING TIME TEST CIRCUIT

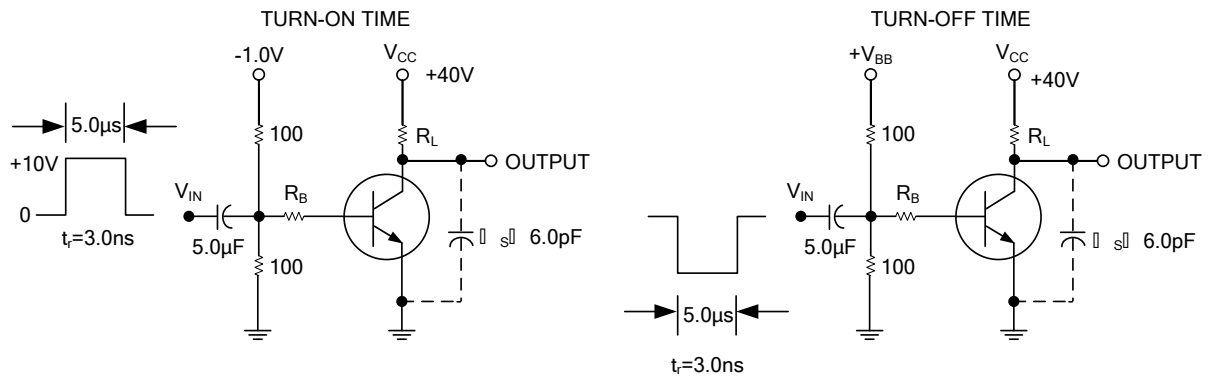

Figure 1. (Note: Total shunt capacitance of test jig and connectors for PNP test circuits, reverse all voltage polarities.)

UTC assumes no responsibility for equipment failures that result from using products at values that exceed, even momentarily, rated values (such as maximum ratings, operating condition ranges, or other parameters) listed in products specifications of any and all UTC products described or contained herein. UTC products are not designed for use in life support appliances, devices or systems where malfunction of these products can be reasonably expected to result in personal injury. Reproduction in whole or in part is prohibited without the prior written consent of the copyright owner. The information presented in this document does not form part of any quotation or contract, is believed to be accurate and reliable and may be changed without notice.