

TRANSISTOR(PNP)

FEATURES

- High breakdown voltage

MARKING: M

MAXIMUM RATINGS (T_A=25°C unless otherwise noted)

Symbol	Parameter	Value	Units
V _{CB0}	Collector-Base Voltage	-55	V
V _{CEO}	Collector-Emitter Voltage	-50	V
V _{EBO}	Emitter-Base Voltage	-5	V
I _C	Collector Current -Continuous	-150	mA
P _C	Collector Power Dissipation	200	mW
T _J	Junction Temperature	150	°C
T _{stg}	Storage Temperature	-55-150	°C

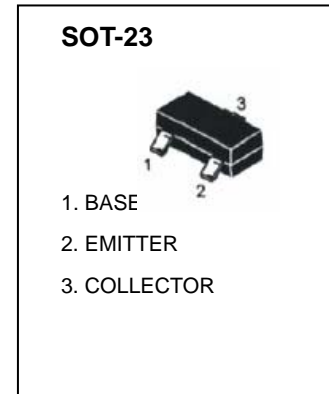

ELECTRICAL CHARACTERISTICS (T_{amb}=25°C unless otherwise specified)

Parameter	Symbol	Test conditions	MIN	TYP	MAX	UNIT
Collector-base breakdown voltage	V _{(BR)CBO}	I _C =-10u A, I _E =0	-55			V
Collector-emitter breakdown voltage	V _{(BR)CEO}	I _C =-1mA, I _B =0	-50			V
Emitter-base breakdown voltage	V _{(BR)EBO}	I _E =-10 u A, I _C =0	-5			V
Collector cut-off current	I _{CBO}	V _{CB} =-35V, I _E =0			-0.1	u A
Emitter cut-off current	I _{EBO}	V _{EB} =-4V, I _C =0			-0.1	u A
DC current gain	h _{FE}	V _{CE} =-6V, I _C =-1mA	200		400	
Collector-emitter saturation voltage	V _{CE(sat)}	I _C =-50mA, I _B =-5mA			-0.5	V
Base -emitter saturation voltage	V _{BE(sat)}	I _C =-50mA, I _B =-5mA			-1.0	V
Transition frequency	f _T	V _{CE} =-6V, I _C =-10mA		180		MHz
Collector output capacitance	C _{ob}	V _{CB} =-6V, I _E =0, f=1MHz		4		pF

Typical Characteristics

