

Optical Pickup Chipset with Photodetector ICs
Supports High-Speed Writing to CD and DVD

CXA2702GA/CXA2716GA/CXA2701GA

Although it has only been a year since Sony released the CXA2676GA and CXA2677GA* for DVD $\times 8$ -speed recording, DVD recording speed has already reached $\times 16$.

Sony's newly-developed CXA2701GA and CXA2702GA/CXA2716GA optical pickup photodetector ICs (PDICs) support this $\times 16$ record speed.

*: See CX-News, Volume 32, for details on the CXA2676GA and CXA2677GA.

CXA2702GA/CXA2716GA

RF/Servo PDICs

- Supports high-speed CD/DVD write operations (CD-R: $\times 52$ -speed, DVD-R: $\times 16$ -speed)
- WPP1 (B+C) and WPP2 (A+D) outputs, which are optimal for DVD address pit detection
- Variable limiter function
- CXA2702GA: Eight-division photodiode
CXA2716GA: Twelve-division photodiode
- 18-pin LGA COB small package

CXA2701GA

Laser Front Monitor PDIC

- Differential output
- Two-channel structure (Vin1, Vin2)
- 12-pin LGA COB small package

■ CXA2702GA/CXA2716GA

The CXA2702GA is a photodetector IC (PDIC) that was developed as the photodetector for optical pickups used in DVD \pm R/RW recording drives. Like the earlier $\times 8$ -speed CXA2677GA, it provides the WPP1 and WPP2 signals that are optimal for address pit signal detection. In increasing the recording speed to $\times 16$, Sony added a $3\times$ gain switching function to WPP1 and WPP2. The new IC thus has an additional 2 bits of control compared to the earlier gain switching system. The CXA2702GA also now provides an input pin that can control the output limiter volt-

age externally so that applications can set the limiter voltage to provide optimal pickup performance. Note that although the CXA2702GA includes a built-in 8-division photodiode that supports the same differential push-pull method as the earlier product (CXA2677GA), Sony has also added to the product lineup the CXA2716GA, which includes a built-in 12-division photodiode that supports the differential astigmatism method. Both the CXA2702GA and CXA2716GA feature the extremely fast main output settling time (for a 1 V amplitude) of 6 ns.

■ CXA2701GA

Like the earlier $\times 8$ -speed CXA2676GA, the CXA2701GA adopts a two-channel structure to allow the CD laser and the DVD laser power levels to be set individually. However, the output was changed to the differential type in this new product. This was because the output at the read power became even smaller due to lowering the gain of the first stage I-V amplifier (transimpedance amplifier) to $1/\sqrt{2}$ to support $\times 16$ -speed laser diodes. Switching to a differential amplifier improves the signal-to-noise ratio by $\sqrt{2}$ and also allows the common mode noise in the transmission system to be cancelled.

■ Support for Lead-Free Mounting

Since the chip on board (COB) package adopted for these ICs has excellent resistance to heat, these ICs support mounting with lead-free solder. They allow two-pass reflow mounting with a peak temperature of 250°C.

Note: Since the thermal resistance is strongly influenced by the usage environment, verify the details of the specifications in advance, or contact your Sony representative for consultation.

V O I C E

Our achievement of $\times 16$ -speed DVD recording required pushing our circuit technologies to the limit to get the utmost performance from Sony's process technologies. The two of us on this development team had to come up with a lot of mutual support and encouragement during this design effort. We are probably not the only ones who are hoping that this achievement marks the end of the competition for ever higher speeds.

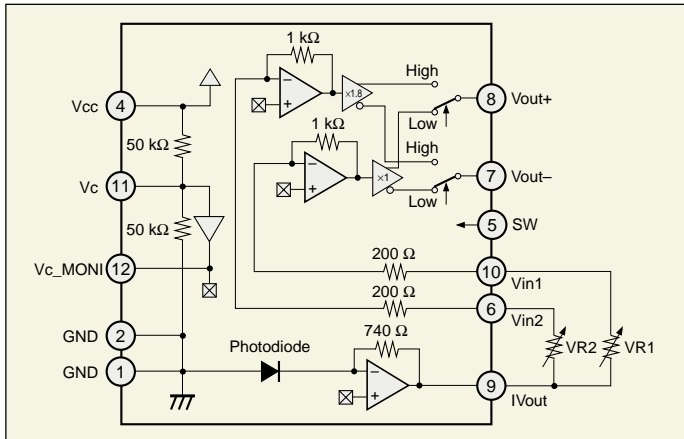

■ Figure 1 CXA2701GA Block Diagram

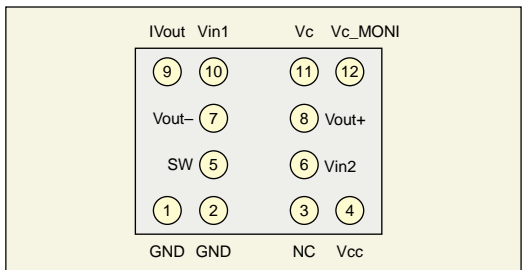

■ Figure 3 CXA2701GA Pin Configuration

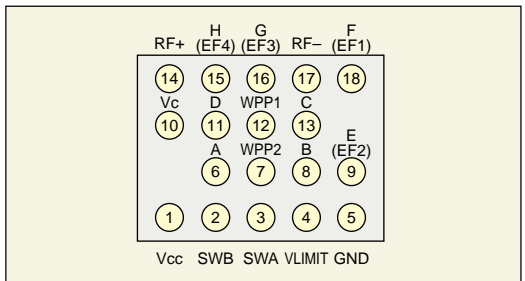

■ Figure 4 CXA2702GA Pin Configuration (Items in parentheses apply to the CXA2716GA.)

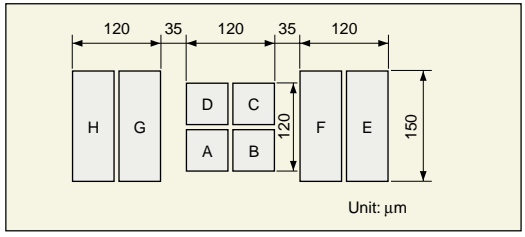

■ Figure 6 CXA2702GA Acceptance Pattern Dimensions

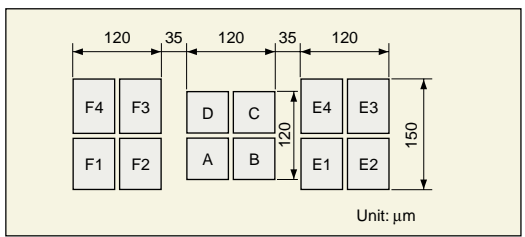

■ Figure 7 CXA2716GA Acceptance Pattern Dimensions

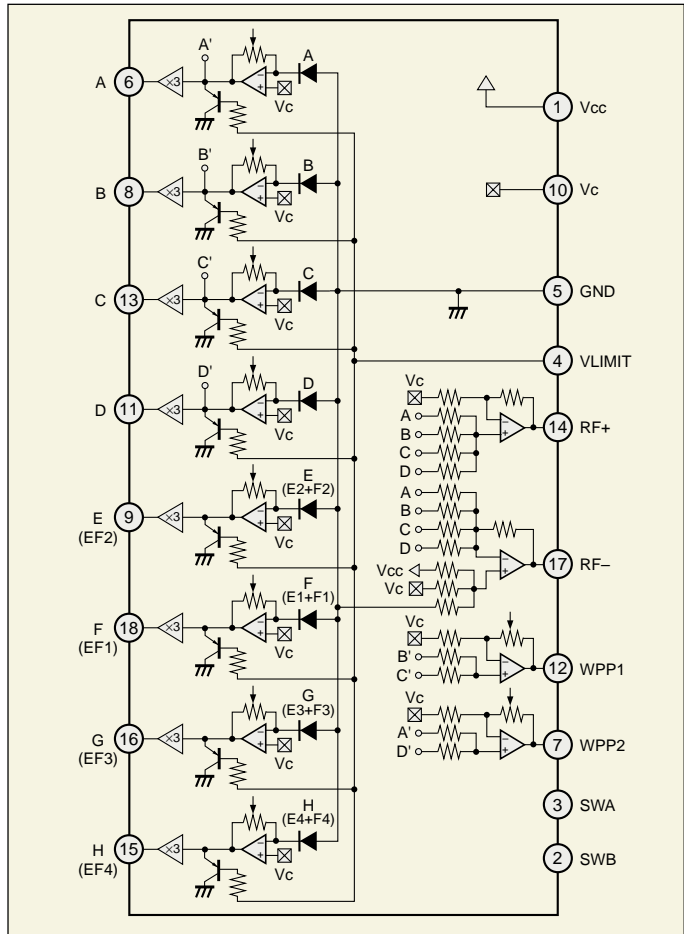

■ Figure 2 CXA2702GA Block Diagram (Items in parentheses apply to the CXA2716GA.)

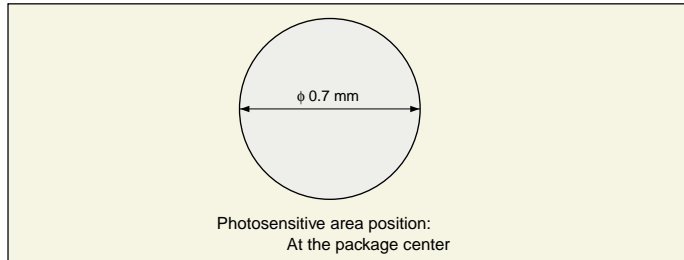

■ Figure 5 CXA2701GA Acceptance Pattern Dimensions

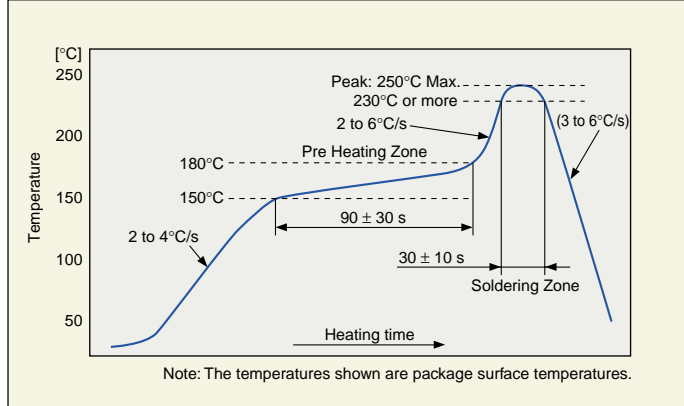

■ Figure 8 Recommended Reflow Soldering Temperature Profile (Lead-free soldering)