

**PRELIMINARY**



# **ISD1720**

**Multi-Message**

**Single-Chip**

**Voice Record & Playback Device**

*Publication Release Date: April 4, 2007  
Revision 0*

## ISD1720



## TABLE OF CONTENTS

1	GENERAL DESCRIPTION .....	3
2	FEATURES.....	4
3	BLOCK DIAGRAM.....	5
4	PINOUT CONFIGURATION.....	6
5	PIN DESCRIPTION .....	7
6	MODES OF OPERATIONS .....	8
	6.1 Standalone (Push-Button) Mode .....	8
	6.2 SPI Mode .....	8
7	TIMING DIAGRAMS .....	8
	7.1 Basic Operation .....	8
	7.2 SPI Operation.....	12
8	ABSOLUTE MAXIMUM RATINGS .....	13
	8.1 Operating Conditions .....	13
9	ELECTRICAL CHARACTERISTICS .....	14
	9.1 DC Parameters .....	14
	9.2 AC Parameters.....	15
10	TYPICAL APPLICATION CIRCUITS.....	16
	10.1 Good Audio Design Practices .....	18
11	PACKAGING .....	19
	11.1 28-Lead 8x13.4mm Plastic Thin Small Outline Package (TSOP) Type 1 - IQC.....	19
	11.2 28-Lead 300-Mil Plastic Small Outline Integrated Circuit (SOIC).....	20
	11.3 28-Lead 600-Mil Plastic Dual Inline Package (PDIP) .....	21
	11.4 Die Information.....	21
12	ORDERING INFORMATION .....	22
13	VERSION HISTORY.....	23

# ISD1720



## 1 GENERAL DESCRIPTION

The Winbond® ISD1720 ChipCorder® is a high quality, fully integrated, single-chip multi-message voice record and playback device ideally suited to a variety of electronic systems. The message duration is user selectable in ranges from 26 seconds to 120 seconds, depending on the specific device. The sampling frequency of each device can also be adjusted from 4 kHz to 12 kHz with an external resistor, giving the user greater flexibility in duration versus recording quality for each application. Operating voltage spans a range from 2.4 V to 5.5 V to ensure that the ISD1720 device are optimized for a wide range of battery or line-powered applications.

The ISD1720 is designed for operation in either standalone or microcontroller (SPI) mode. The device incorporates a proprietary message management system that allows the chip to self-manage address locations for multiple messages. This unique feature provides sophisticated messaging flexibility in a simple push-button environment. The device include an on-chip oscillator (with external resistor control), microphone preamplifier with Automatic Gain Control (AGC), an auxiliary analog input, anti-aliasing filter, Multi-Level Storage (MLS) array, smoothing filter, volume control, Pulse Width Modulation (PWM) Class D speaker driver, and current/voltage output.

The ISD1720 device also support an optional “vAlert” (voiceAlert) feature that can be used as a new message indicator. With vAlert, the device flashes an external LED to indicate that a new message is present. Besides, four special sound effects are reserved for audio confirmation of operations, such as “Start Record”, “Stop Record”, “Erase”, “Forward”, “Global Erase”, and etc.

Recordings are stored into on-chip Flash memory, providing zero-power message storage. This unique single-chip solution is made possible through Winbond’s patented Multi-Level Storage (MLS) technology. Audio data are stored directly in solid-state memory without digital compression, providing superior quality voice and music reproduction.

Voice signals can be fed into the chip through two independent paths: a differential microphone input and a single-ended analog input. For outputs, the ISD1720 provides a Pulse Width Modulation (PWM) Class D speaker driver and a separate analog output simultaneously. The PWM can directly drive a standard 8Ω speaker or typical buzzer, while the separate analog output can be configured as a single-ended current or voltage output to drive an external amplifier.

While in Standalone mode, the ISD1720 device automatically enter into power down mode for power conservation after an operation is completed.

In the SPI mode, the user has full control via the serial interface in operating the device. This includes random access to any location inside the memory array by specifying the start address and end address of operations. SPI mode also allows access to the Analog Path Configuration (APC) register. This register allows flexible configuration of audio paths, inputs, outputs and mixing. The APC default configuration for standalone mode can also be modified by storing the APC data into a non-volatile register (NVCFG) that is loaded at initialization. Utilizing the capabilities of ISD1720 Device, designers have the control and flexibility to implement voice functionality into the high-end products.

Notice: The specifications are subject to change without notice. Please contact Winbond Sales Offices or Representatives to verify current or future specifications. Also refer to the website for any related application notes.

## ISD1720



## 2 FEATURES

- Integrated message management systems for single-chip, push-button applications
  - $\overline{\text{REC}}$  : level-trigger for recording
  - $\overline{\text{PLAY}}$  : edge-trigger for individual message or level-trigger for looping playback sequentially
  - $\overline{\text{ERASE}}$  : edge-triggered erase for first or last message or level-triggered erase for all messages
  - $\overline{\text{FWD}}$  : edge-trigger to advance to the next message or fast message scan during the playback
  - $\overline{\text{VOL}}$  : 8 levels output volume control
  - $\text{RDY}/\overline{\text{INT}}$  : ready or busy status indication
  - $\overline{\text{RESET}}$  : return to the default state
  - Automatic power-down after each operation cycle

- Selectable sampling frequency controlled by an external oscillator resistor

Sampling Frequency	12 kHz	8 kHz	6.4 kHz	5.3 kHz	4 kHz
Rosc	53 k $\Omega$	80 k $\Omega$	100 k $\Omega$	120 k $\Omega$	160 k $\Omega$

- Selectable message duration
  - A wide range selection from 20 secs to 480 secs pending upon sampling frequency chosen

Sample Freq.	12 kHz	8 kHz	6.4 kHz	5.3 kHz	4 kHz
Duration	12 secs	18 secs	22.5 secs	27 secs	36 secs

- Message and operation indicators
  - Four customizable Sound Effects (SEs) for audible indication
  - Optional vAlert (voiceAlert) to indicate the presence of new messages
  - LED: stay on during recording, blink during playback, forward and erase operations
- Dual operating modes
  - *Standalone mode*:
    - Integrated message management techniques
    - Automatic power-down after each operation cycle
  - *SPI mode*:
    - Fully user selectable and controllable options via APC register and various SPI commands
- Two individual input channels
  - MIC+/MIC-: differential microphone inputs with AGC (Automatic Gain Control)
  - Analn: single-ended auxiliary analog input for recording or feed-through
- Dual output channels
  - Differential PWM Class D speaker outputs directly drives an 8  $\Omega$  speaker or a typical buzzer
  - Configurable AUD (current) or AUX (voltage) single-ended output drives external audio amplifier
- ChipCorder standard features
  - High-quality, natural voice and audio reproduction
  - 2.4V to 5.5V operating voltage
  - 100-year message retention (typical)
  - 100,000 record cycles (typical)
- Temperature options:
  - Commercial: 0°C to +50°C (die); 0°C to +70°C (packaged units)
  - Industrial: -40°C to +85°C (packaged units)
- Lead-free packaging types: available in die, PDIP, SOIC and TSOP

# ISD1720



## 3 BLOCK DIAGRAM

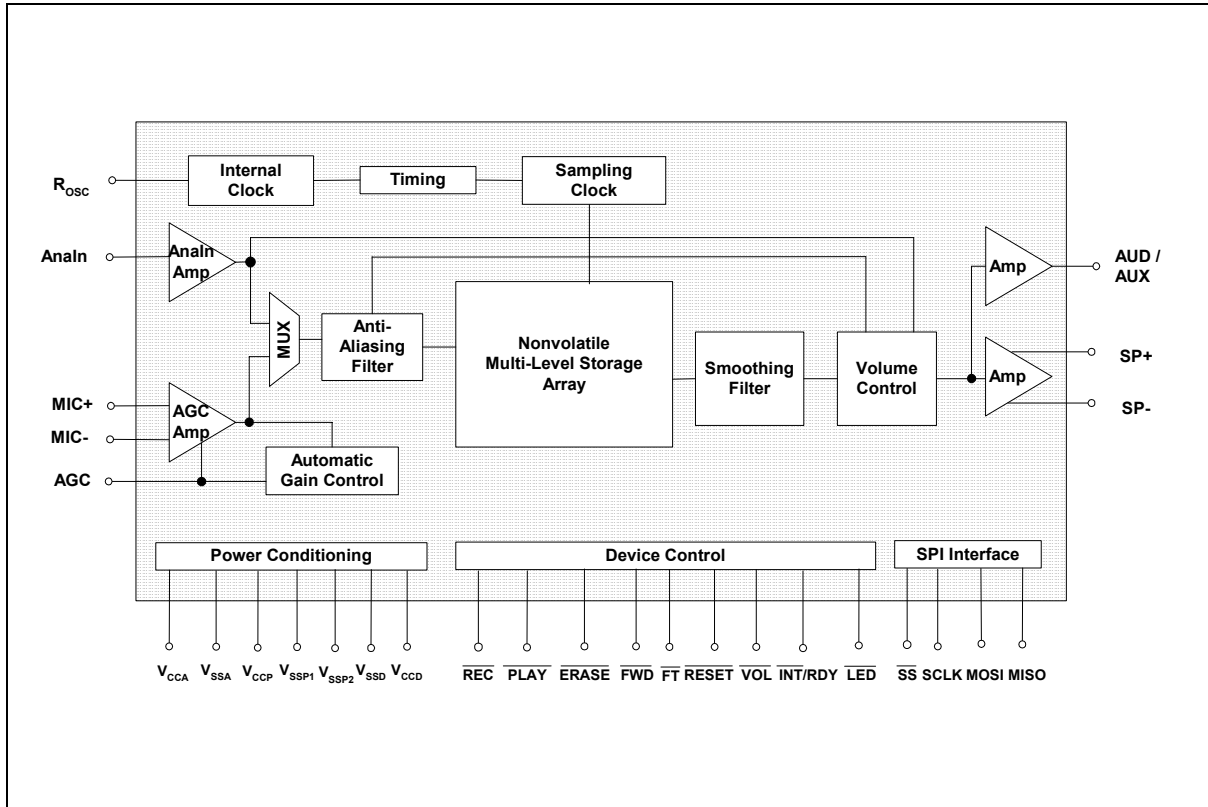

# ISD1720



## 4 PINOUT CONFIGURATION

Refer to Design Guide for details before performing any design or PCB layout.

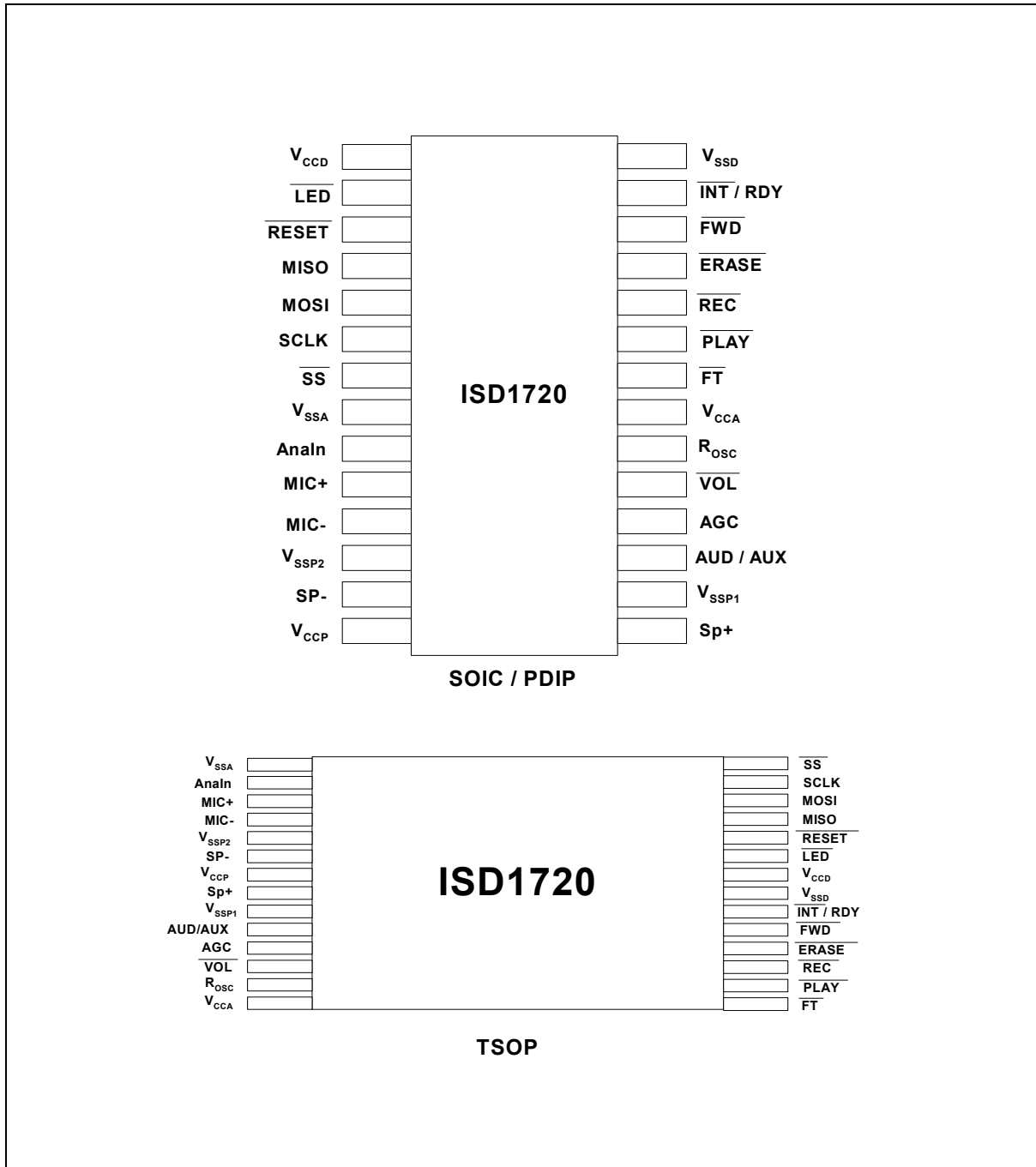

## ISD1720



## 5 PIN DESCRIPTION

Refer to Design Guide for details before performing any design or PCB layout.

PIN NAME	FUNCTIONS
V <sub>CCD</sub>	<b>Digital Power Supply:</b> Power supply for digital circuitry.
$\overline{\text{LED}}$	<b>LED:</b> An LED output.
$\overline{\text{RESET}}$	<b>RESET:</b> When active, the device enters into a known state.
MISO	<b>Master In Slave Out:</b> Data is shifted out on the falling edge of SCLK. When the SPI is inactive ( $\overline{\text{SS}}$ = high), it's tri-state.
MOSI	<b>Master Out Slave In:</b> Data input of the SPI interface when ISD1718 is a slave. Data is latched into the device on the rising edge of SCLK.
SCLK	<b>Serial Clock:</b> Clock of the SPI interface.
$\overline{\text{SS}}$	<b>Slave Select:</b> Selects as a slave device and enables the SPI interface.
V <sub>SSA</sub>	<b>Analog Ground:</b> Ground path for analog circuitry.
Analn	<b>Analn:</b> Auxiliary analog input to the device for recording or feed-through.
MIC+	<b>MIC+:</b> Non-inverting input of the differential microphone signal.
MIC-	<b>MIC-:</b> Inverting input of the differential microphone signal.
V <sub>SSP2</sub>	<b>Ground:</b> Ground path for negative PWM speaker drive.
SP-	<b>SP-:</b> The negative Class D PWM speaker output.
V <sub>CCP</sub>	<b>Power Supply for PWM Speaker Driver:</b> Power for PWM speaker drive.
SP+	<b>SP+:</b> The positive Class D PWM speaker output.
V <sub>SSP1</sub>	<b>Ground:</b> Ground path for positive PWM speaker drive.
AUD/AUX	<b>Auxiliary Output:</b> Either an AUD (current) or AUX (voltage) output.
AGC	<b>Automatic Gain Control (AGC):</b> The AGC adjusts the gain of the microphone preamplifier circuitry.
$\overline{\text{VOL}}$	<b>Volume:</b> This control has 8 levels of volume adjustment.
R <sub>OSC</sub>	<b>Oscillator Resistor:</b> A resistor determines the sample frequency of the device, which sets the duration.
V <sub>CCA</sub>	<b>Analog Power Supply.</b> Power supply for analog circuitry.
$\overline{\text{FT}}$	<b>Feed-through:</b> Enable the feed-through path for Analn signal to the outputs.
$\overline{\text{PLAY}}$	<b>Playback:</b> Plays the recorded message individually, or plays messages sequential in a looping mode.
$\overline{\text{REC}}$	<b>Record:</b> When active, starts recording message.
$\overline{\text{ERASE}}$	<b>Erase:</b> When active, can erase individual message or do global erase.
$\overline{\text{FWD}}$	<b>Forward:</b> Advances to the next message from the current location.
RDY/ $\overline{\text{INT}}$	An open drain output. Can review ready or interrupt status.
V <sub>SSD</sub>	<b>Digital Ground:</b> Ground path for digital circuitry

## ISD1720



## 6 MODES OF OPERATIONS

The ISD1720 Device can operate in either Standalone (Push-Button) or microcontroller (SPI) mode.

### 6.1 STANDALONE (PUSH-BUTTON) MODE

One can utilize the  $\overline{\text{REC}}$ ,  $\overline{\text{PLAY}}$ ,  $\overline{\text{FT}}$ ,  $\overline{\text{FWD}}$ ,  $\overline{\text{ERASE}}$ ,  $\overline{\text{VOL}}$  or  $\overline{\text{RESET}}$  control to initiate a desired operation. As completed, the device automatically enters into the power-down state.

### 6.2 SPI MODE

In SPI mode, control of the device is achieved through the 4-wire serial interface via SPI commands.

For technical details, please refer to the design guide.

## 7 TIMING DIAGRAMS

The following estimated timing diagrams are not in proper scale.

### 7.1 BASIC OPERATION

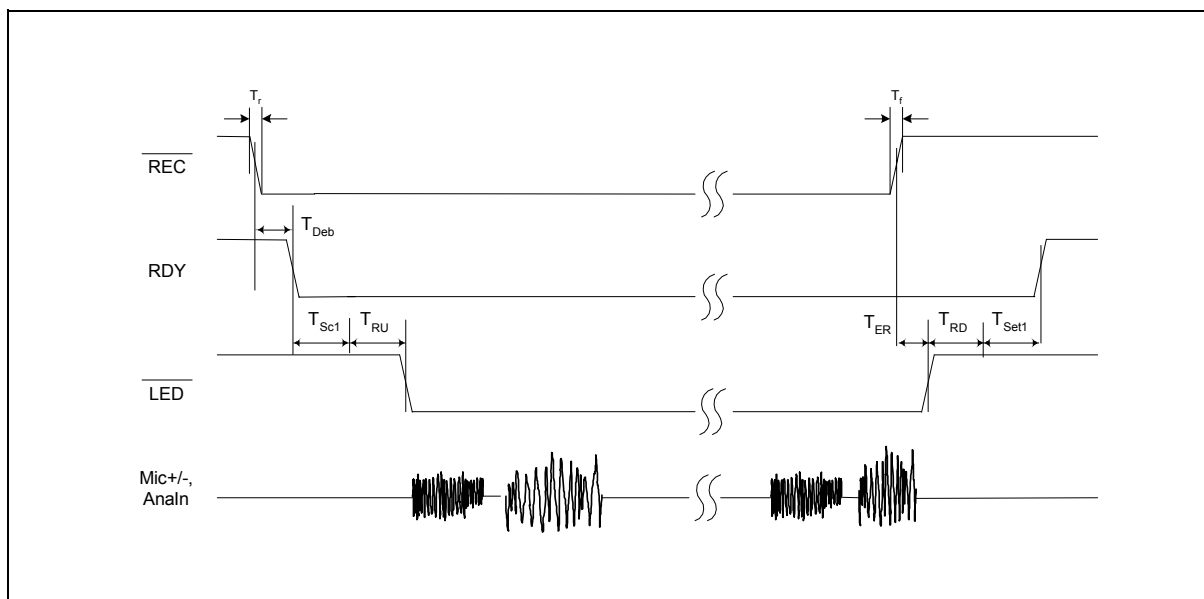

Figure 12.1: Record Operation with No Sound Effect



# ISD1720

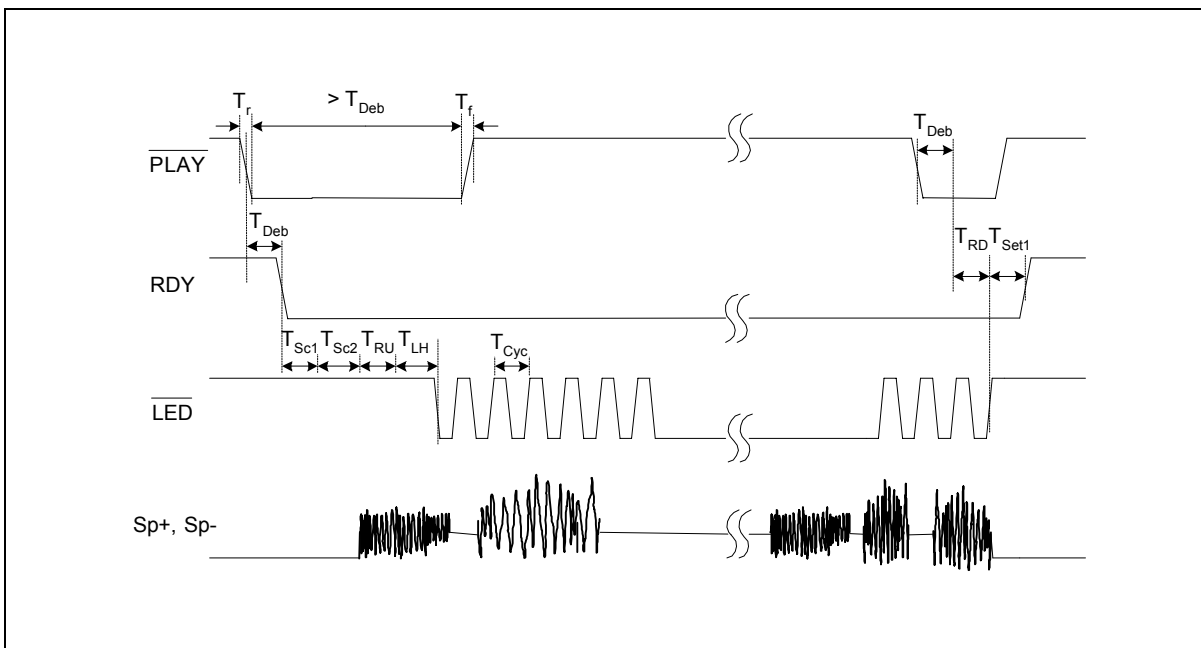

Figure 12.2: Start and Stop Playback Operation

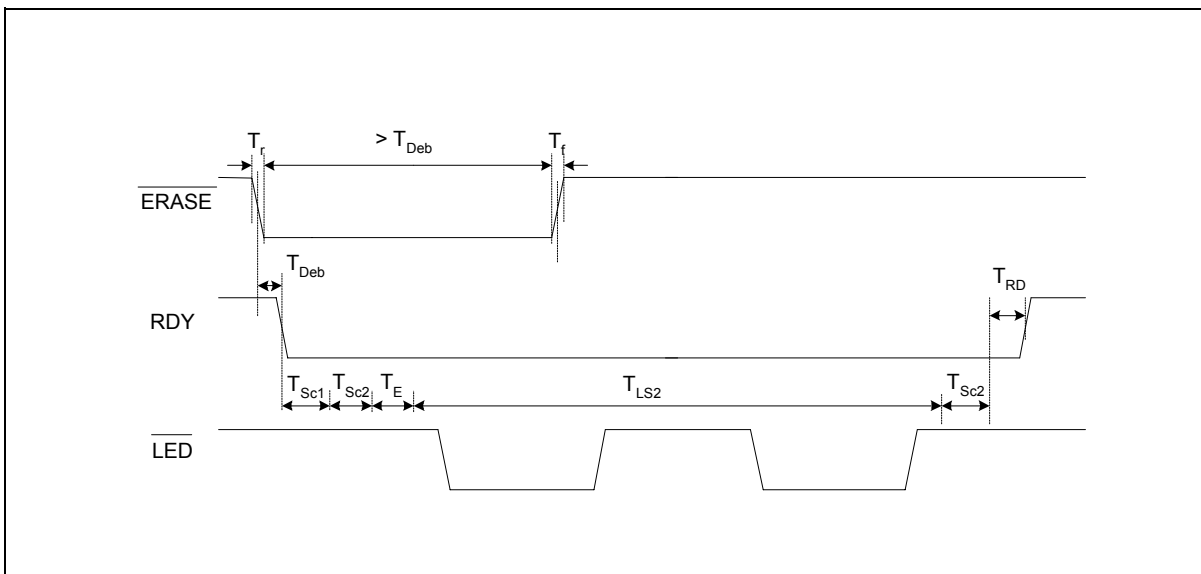

Figure 12.3: Single Erase Operation with No Sound Effect

# ISD1720

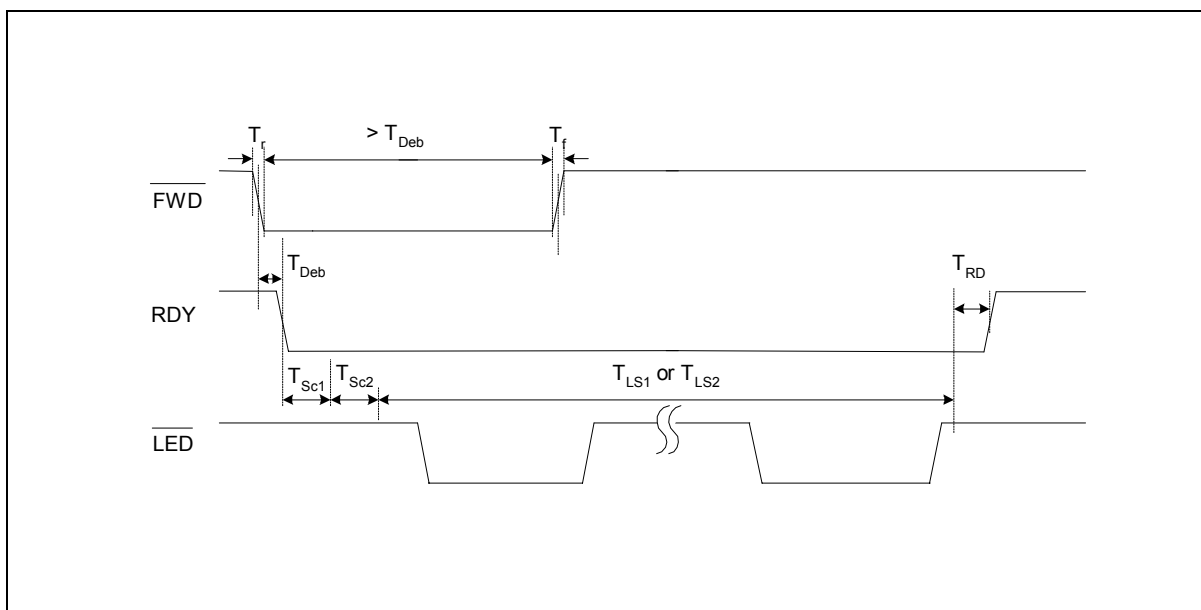

Figure 12.4: Forward Operation with No Sound Effect

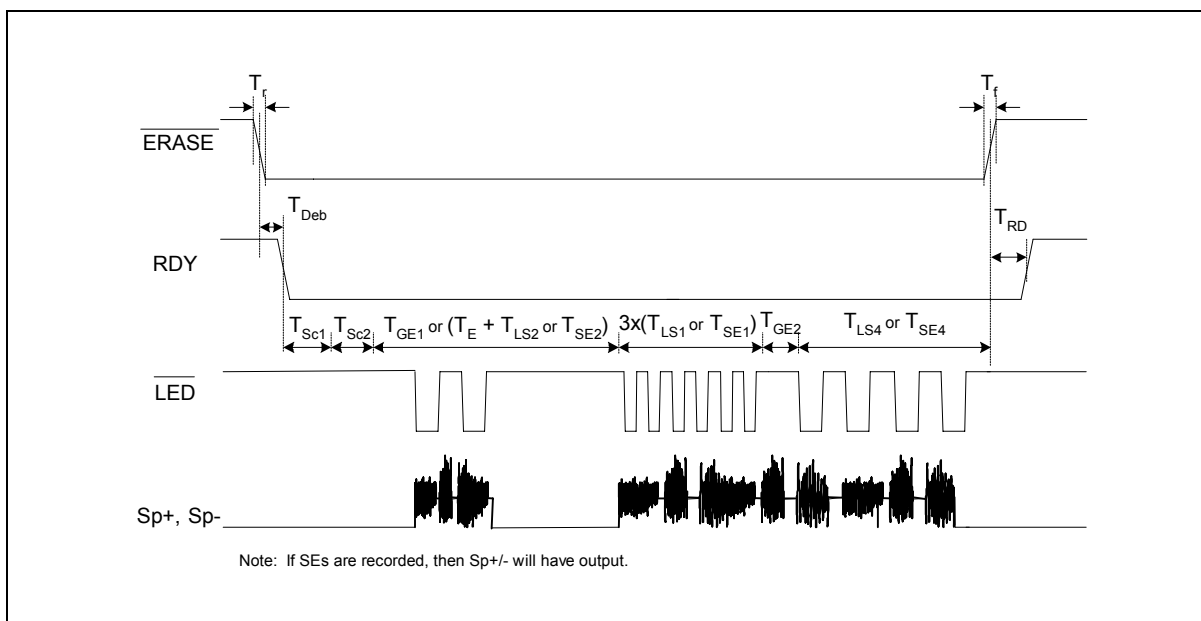

Figure 12.5: Global Erase Operation with or without Sound Effects

# ISD1720

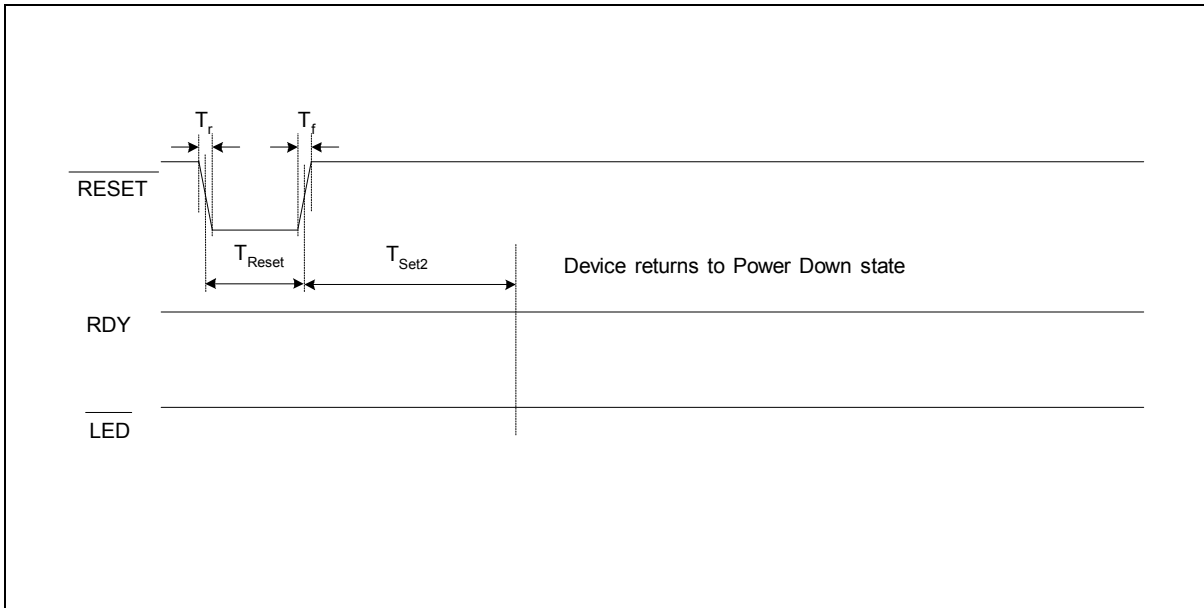

Figure 12.6: Reset Operation

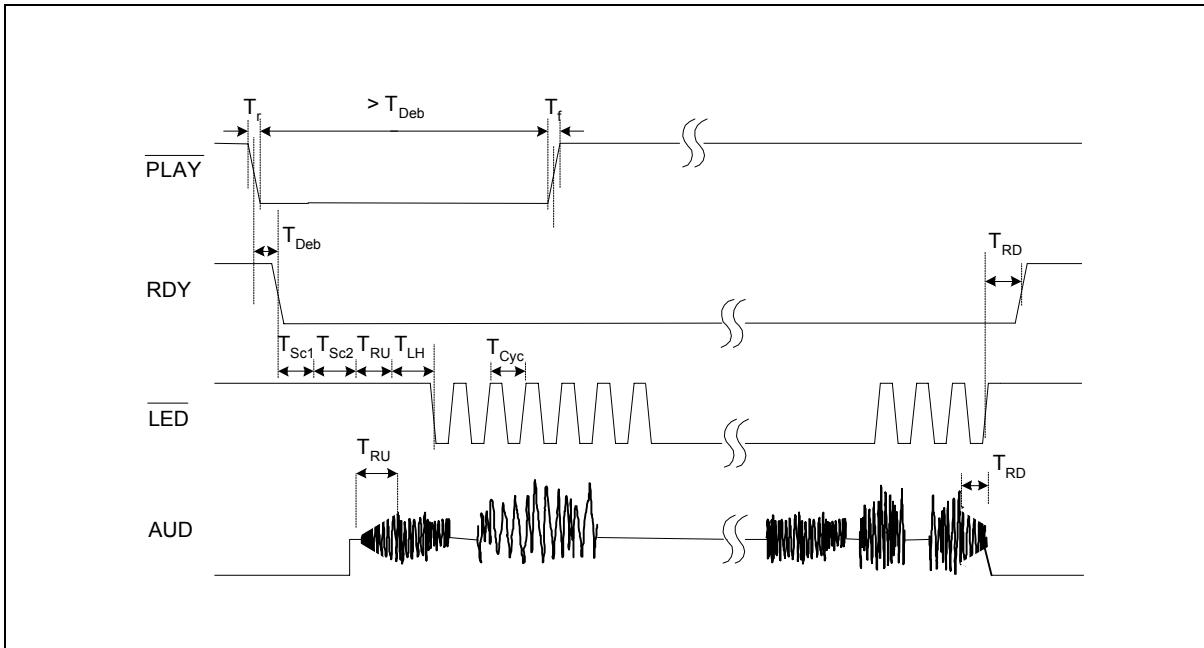

Figure 12.7: Playback Operation with ramp up and ramp down effect at AUD output

## ISD1720



## 7.2 SPI OPERATION

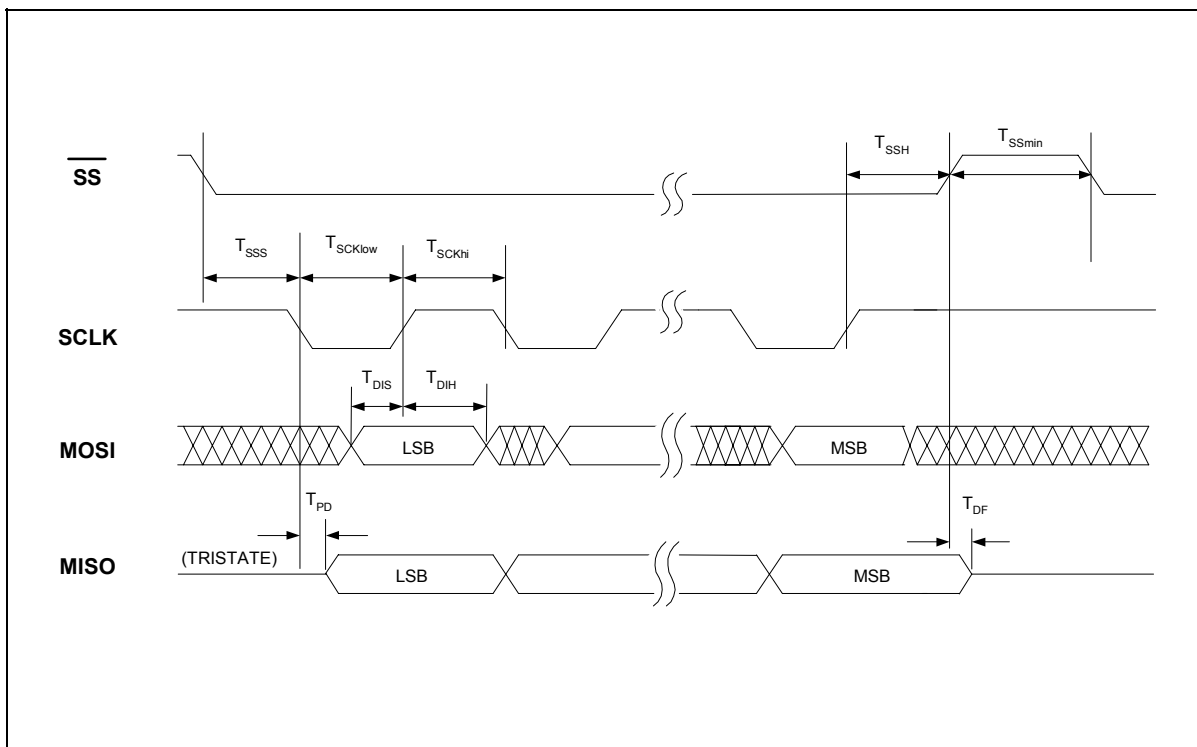

Figure 12.8: SPI Operation

PARAMETER	SYMBOL	MIN	TYP	MAX	UNITS
SS Setup Time	$T_{SSS}$	500			nsec
SS Hold Time	$T_{SSH}$	500			nsec
Data in Setup Time	$T_{DIS}$	200			nsec
Data in Hold Time	$T_{DIH}$	200			nsec
Output Delay	$T_{PD}$			500	nsec
Output Delay to HighZ	$T_{DF}$			500	nsec
SS HIGH	$T_{SSmin}$	1			$\mu$ sec
SCLK High Time	$T_{SCKhi}$	400			nsec
SCLK Low Time	$T_{SCKlow}$	400			nsec
CLK Frequency	$F_0$			1,000	KHz
Power-Up Delay <sup>[1]</sup>	$T_{PUD}$		50		msec

Notes: <sup>[1]</sup> The value shown is based upon 8 kHz sampling frequency. Delay increases proportionally for slower sampling frequency.

## ISD1720



## 8 ABSOLUTE MAXIMUM RATINGS

ABSOLUTE MAXIMUM RATINGS (DIE) <sup>[1]</sup>

CONDITIONS	VALUES
Junction temperature	150°C
Storage temperature range	-65°C to +150°C
Voltage Applied to any pads	(V <sub>SS</sub> - 0.3V) to (V <sub>CC</sub> + 0.3V)
Power supply voltage to ground potential	-0.3V to +7.0V

ABSOLUTE MAXIMUM RATINGS (PACKAGED PARTS) <sup>[1]</sup>

CONDITIONS	VALUES
Junction temperature	150°C
Storage temperature range	-65°C to +150°C
Voltage Applied to any pins	(V <sub>SS</sub> - 0.3V) to (V <sub>CC</sub> + 0.3V)
Voltage applied to any pin (Input current limited to +/-20 mA)	(V <sub>SS</sub> - 1.0V) to (V <sub>CC</sub> + 1.0V)
Power supply voltage to ground potential	-0.3V to +7.0V

<sup>[1]</sup> Stresses above those listed may cause permanent damage to the device. Exposure to the absolute maximum ratings may affect device reliability. Functional operation is not implied at these conditions.

## 8.1 OPERATING CONDITIONS

## OPERATING CONDITIONS (DIE)

CONDITIONS	VALUES
Operating temperature range	0°C to +50°C
Supply voltage (V <sub>CC</sub> ) <sup>[1]</sup>	+2.4 V to +5.5 V
Ground voltage (V <sub>SS</sub> ) <sup>[2]</sup>	0 V
Input voltage (V <sub>CC</sub> ) <sup>[1]</sup>	0 V to 5.5 V
Voltage applied to any pins	(V <sub>SS</sub> - 0.3 V) to (V <sub>CC</sub> + 0.3 V)

## OPERATING CONDITIONS (PACKAGED PARTS)

CONDITIONS	VALUES
Operating temperature range (Case temperature)	-40°C to +85°C
Supply voltage (V <sub>DD</sub> ) <sup>[1]</sup>	+2.4V to +5.5V
Ground voltage (V <sub>SS</sub> ) <sup>[2]</sup>	0V
Input voltage (V <sub>DD</sub> ) <sup>[1]</sup>	0V to 5.5V
Voltage applied to any pins	(V <sub>SS</sub> - 0.3V) to (V <sub>DD</sub> + 0.3V)

<sup>[1]</sup> V<sub>CC</sub> = V<sub>CCA</sub> = V<sub>CDD</sub> = V<sub>CCP</sub>

<sup>[2]</sup> V<sub>SS</sub> = V<sub>SSA</sub> = V<sub>SSD</sub> = V<sub>SSP1</sub> V<sub>SSP2</sub>

## ISD1720



## 9 ELECTRICAL CHARACTERISTICS

## 9.1 DC PARAMETERS

PARAMETER	SYMBOL	MIN	TYP <sup>[1]</sup>	MAX	UNITS	CONDITIONS
Supply Voltage	$V_{DD}$	2.4		5.5	V	
Input Low Voltage	$V_{IL}$	$V_{SS}-0.3$		$0.3 \times V_{DD}$	V	
Input High Voltage	$V_{IH}$	$0.7 \times V_{DD}$		$V_{DD}$	V	
Output Low Voltage	$V_{OL}$	$V_{SS}-0.3$		$0.3 \times V_{DD}$	V	$I_{OL} = 4.0 \text{ mA}^{[2]}$
Output High Voltage	$V_{OH}$	$0.7 \times V_{DD}$		$V_{DD}$	V	$I_{OH} = -1.6 \text{ mA}^{[2]}$
Record Current	$I_{DD\_Record}$		20		mA	$V_{DD} = 5.5 \text{ V}$ , No load, Sampling freq = 12 kHz
Playback Current	$I_{DD\_Playback}$		20		mA	
Erase Current	$I_{DD\_Erase}$		20		mA	
Standby Current	$I_{SB}$		1	10	$\mu\text{A}$	<sup>[3]</sup> <sup>[4]</sup>
Input Leakage Current	$I_{ILPD1}$			$\pm 1$	$\mu\text{A}$	Force $V_{DD}$
Input Current Low	$I_{ILPD2}$	-3		-10	$\mu\text{A}$	Force $V_{SS}$ , others at $V_{CC}$
Preamplifier Input Impedance	$R_{MIC+}, R_{MIC-}$		7		k $\Omega$	Power-up AGC
Analogue Input Impedance	$R_{Analog}$		42		k $\Omega$	When active
MIC Differential Input	$V_{IN1}$	15		300	mV	Peak-to-Peak <sup>[5]</sup>
Analogue Input Voltage	$V_{IN2}$			1	V	Peak-to-Peak
Gain from MIC to SP+/-	$A_{MSP}$	6		40	dB	$V_{IN} = 15 \sim 300 \text{ mV}$ , AGC = $4.7 \mu\text{F}$ , $V_{CC} = 2.4 \text{ V} \sim 5.5 \text{ V}$
Speaker Output Load	$R_{SPK}$	8			$\Omega$	Across both Speaker pins
AUX Output Load	$R_{AUX}$	5			k $\Omega$	When active
Speaker Output Power	$P_{out}$		670		mW	$V_{DD} = 5.5 \text{ V}$ $V_{DD} = 4.4 \text{ V}$ $V_{DD} = 3 \text{ V}$ $V_{DD} = 2.4 \text{ V}$ 1Vp-p, 1 kHz sine wave at Analog. $R_{SPK}$ = 8 $\Omega$ .
			313		mW	
			117		mW	
			49		mW	
Speaker Output Voltage	$V_{OUT1}$		$V_{DD}$		V	$R_{SPK} = 8 \Omega$ (Speaker), Typical buzzer
AUX Output Swing	$V_{OUT2}$			1	V	Peak-to-Peak
AUX Output DC Level	$V_{OUT3}$		1.2		V	When active
AUD	$I_{AUD}$		-3.0		mA	$V_{DD} = 4.5 \text{ V}$ , $R_{EXT} = 390 \Omega$
Volume Output	$A_{Vol}$		0 to -28		dB	8 steps of 4dB each reference to output
Total Harmonic Distortion	THD		1		%	15 mV p-p 1 kHz sine wave, Cmessage weighted

Notes: <sup>[1]</sup> Conditions:  $V_{CC} = 4.5 \text{ V}$ , 8 kHz sampling frequency and  $T_A = 25^\circ\text{C}$ , unless otherwise stated.

<sup>[2]</sup> LED output during Record operation.

<sup>[3]</sup>  $V_{CCA}$ ,  $V_{CCD}$  and  $V_{CCP}$  are connected together.  $V_{SSA}$ ,  $V_{SSP1}$ ,  $V_{SSP2}$  and  $V_{SSD}$  are connected together.

<sup>[4]</sup> **REC**, **PLAY**, **FT**, **FWD**, **ERASE**, **VOL** and **RESET** must be at  $V_{CCD}$ .

<sup>[5]</sup> Balanced input signal applied between MIC+ and MIC- as shown in the applications example. Single-ended MIC+ or MIC- input is recommended no more than 150 mV p-p.

## ISD1720



## 9.2 AC PARAMETERS

CHARACTERISTIC	SYMBOL	MIN	TYP <sup>[1]</sup>	MAX	UNITS	CONDITIONS
Sampling Frequency <sup>[2]</sup>	$F_S$	4		12	kHz	<sup>[2]</sup> <sup>[4]</sup>
Duration <sup>[3]</sup>	$T_{Dur}$		Refer to duration table		sec	<sup>[3]</sup>
Rising Time	$T_r$			100	nsec	
Falling Time	$T_f$			100	nsec	
Debounce Time	$T_{Deb}$	$192/F_S$			msec	<sup>[4]</sup>
Ramp Up Time	$T_{RU}$		$128/F_S$		msec	
Ramp Down Time	$T_{RD}$		$128/F_S$		msec	
Initial Scan Time after power is applied	$T_{Sc1}$			$DRN/8/F_S$	msec	$DRN = \text{device row\#}$ <sup>[4]</sup>
Initial Scan Time from PD state	$T_{Sc2}$			$DRN/16/F_S$	msec	After a PB operation is run <sup>[4]</sup>
End Recording Time	$T_{ER}$			$32/F_S$	msec	<sup>[4]</sup>
LED High Time	$T_{LH}$			$0.5K/F_S$	msec	<sup>[4]</sup>
LED Flash Time for SE1	$T_{LS1}$		$3.5K/F_S$		sec	SE1 not recorded <sup>[5]</sup>
LED Flash Time for SE2	$T_{LS2}$		$7.5K/F_S$		sec	SE2 not recorded <sup>[5]</sup>
LED Flash Time for SE3	$T_{LS3}$		$11.5K/F_S$		sec	SE3 not recorded <sup>[5]</sup>
LED Flash Time for SE4	$T_{LS4}$		$15.5K/F_S$		sec	SE4 not recorded <sup>[5]</sup>
SE1 Recorded Duration	$T_{SE1}$			$4K/F_S$	sec	<sup>[4]</sup> <sup>[5]</sup>
SE2 Recorded Duration	$T_{SE2}$			$4K/F_S$	sec	<sup>[4]</sup> <sup>[5]</sup>
SE3 Recorded Duration	$T_{SE3}$			$4K/F_S$	sec	<sup>[4]</sup> <sup>[5]</sup>
SE4 Recorded Duration	$T_{SE4}$			$4K/F_S$	sec	<sup>[4]</sup> <sup>[5]</sup>
Erase Time	$T_E$		$10MRN/F_S$		sec	$MRN = \text{message row \#}$ <sup>[4]</sup>
Global Erase Wait Time	$T_{GE1}$			$20K/F_S$	sec	<sup>[4]</sup> <sup>[5]</sup>
Global Erase Time	$T_{GE2}$		$34/F_S$		sec	
RESET Pulse	$T_{Reset}$	1			$\mu\text{sec}$	All $F_S$ <sup>[4]</sup>
Settle Time	$T_{Set1}$			$128/F_S$	msec	<sup>[4]</sup>
Settle Time after Reset	$T_{Set2}$			$64/F_S$	msec	<sup>[4]</sup>
LED Error Time	$T_{LErr}$			$27.5K/F_S$	msec	<sup>[4]</sup> <sup>[5]</sup>
LED Cycle frequency	$T_{Cyc}$	1		4	Hz	Pending upon $F_S$

Notes: <sup>[1]</sup> Typical values:  $V_{CC} = 4.5\text{V}$ ,  $F_S = 8\text{kHz}$  and @  $T_A = 25^\circ\text{C}$ , unless otherwise stated.

<sup>[2]</sup> Characterization data shows that sampling frequency resolution is  $\pm 5$  percent across temperature and voltage ranges.

<sup>[3]</sup> Characterization data shows that duration resolution is  $\pm 5$  percent across temperature and voltage ranges.

<sup>[4]</sup>  $V_{CC} = 2.4\text{V} \sim 5.5\text{V}$

<sup>[5]</sup>  $K = 1024$



# ISD1720

## 10 TYPICAL APPLICATION CIRCUITS

The following typical applications examples on ISD1720 Device are for references only. They make no representation or warranty that such applications shall be suitable for the use specified. Each design has to be optimized in its own system for the best performance on voice quality, current consumption, functionalities and etc.

The below notes apply to the following applications examples:

- \* These capacitors may be needed in order to optimize for the best voice quality, which is also dependent upon the layout of the PCB. Depending on system requirements, they can be 10  $\mu\text{F}$ , 4.7  $\mu\text{F}$  or other values. Please refer to the applications notes or consult Winbond for layout advice.
- \*\* It is important to have a separate path for each ground and power back to the related terminals to minimize the noise. Also, the power supplies should be decoupled as close to the device as possible.

### Example #1: Recording using microphone input via push-button controls

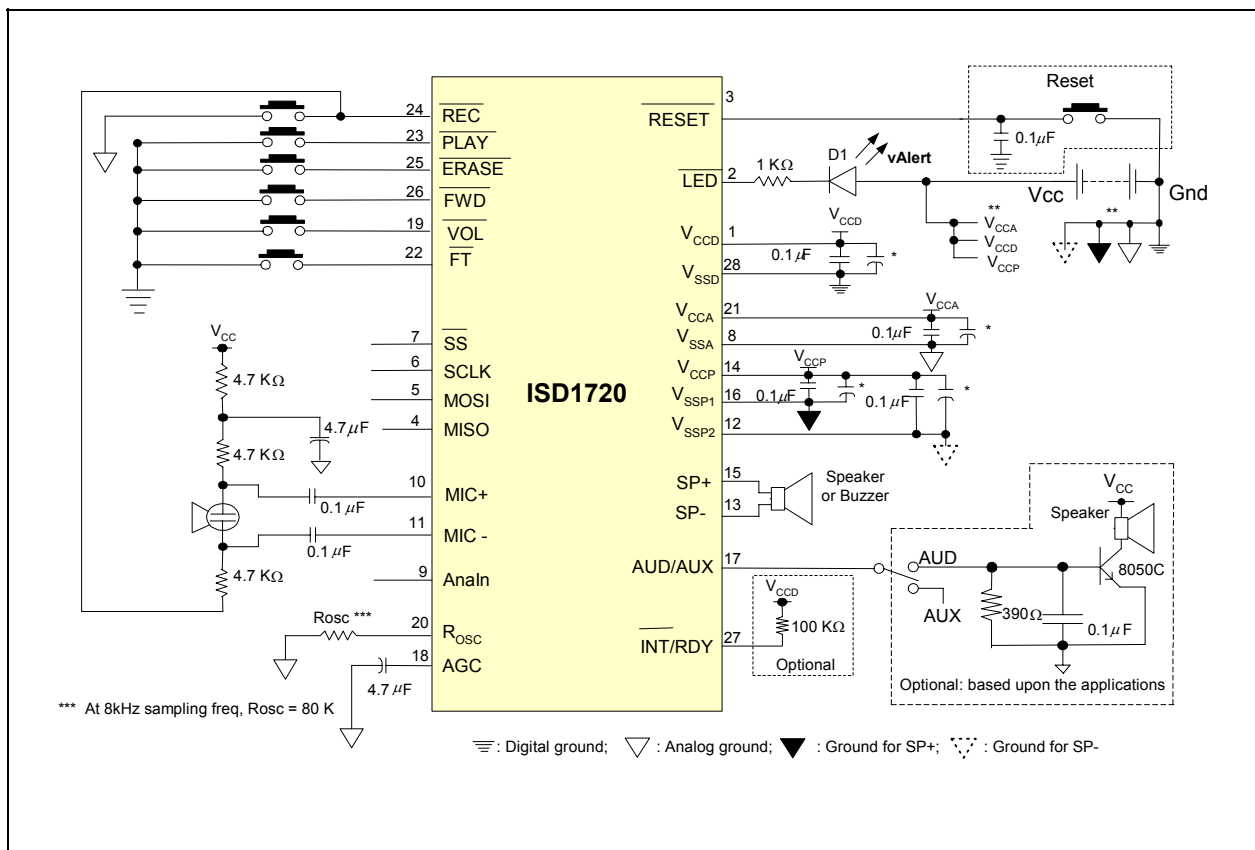



# ISD1720



Example #2: Recording using Analn input via push-button controls

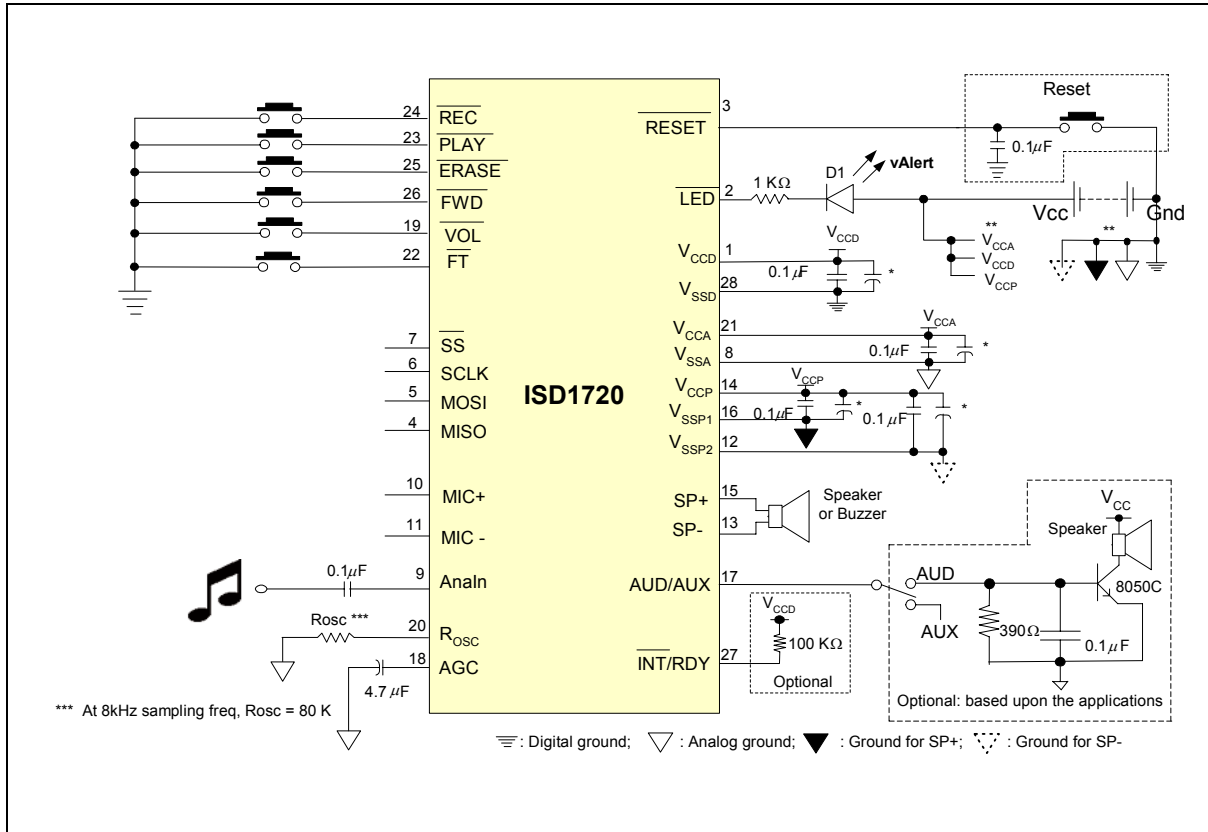

## ISD1720



## Example #3: Connecting the SPI Interface to a microcontroller

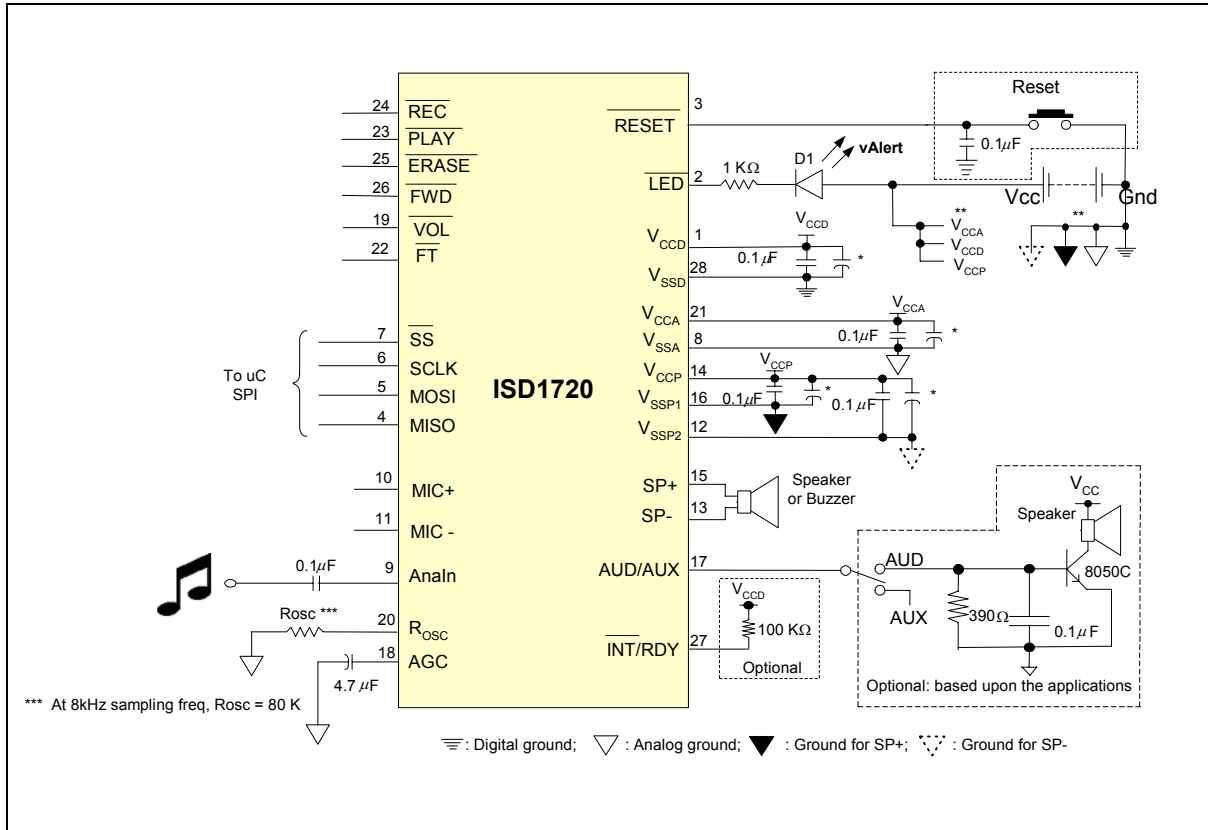

### 10.1 GOOD AUDIO DESIGN PRACTICES

To ensure the highest quality of voice reproduction, it is important to follow good audio design practices in layout and power supply decoupling. See recommendations from below links or other Application Notes in our websites.

Design Considerations for ISD1720 Family

AN-CC1002 Design Considerations for ISD1720 Family.pdf

Good Audio Design Practices

[http://www.winbond-usa.com/products/isd\\_products/chipcorder/applicationinfo/apin11.pdf](http://www.winbond-usa.com/products/isd_products/chipcorder/applicationinfo/apin11.pdf)

Single-Chip Board Layout Diagrams

[http://www.winbond-usa.com/products/isd\\_products/chipcorder/applicationinfo/apin12.pdf](http://www.winbond-usa.com/products/isd_products/chipcorder/applicationinfo/apin12.pdf)

## ISD1720



## 11 PACKAGING

## 11.1 28-LEAD 8x13.4MM PLASTIC THIN SMALL OUTLINE PACKAGE (TSOP) TYPE 1 - IQC

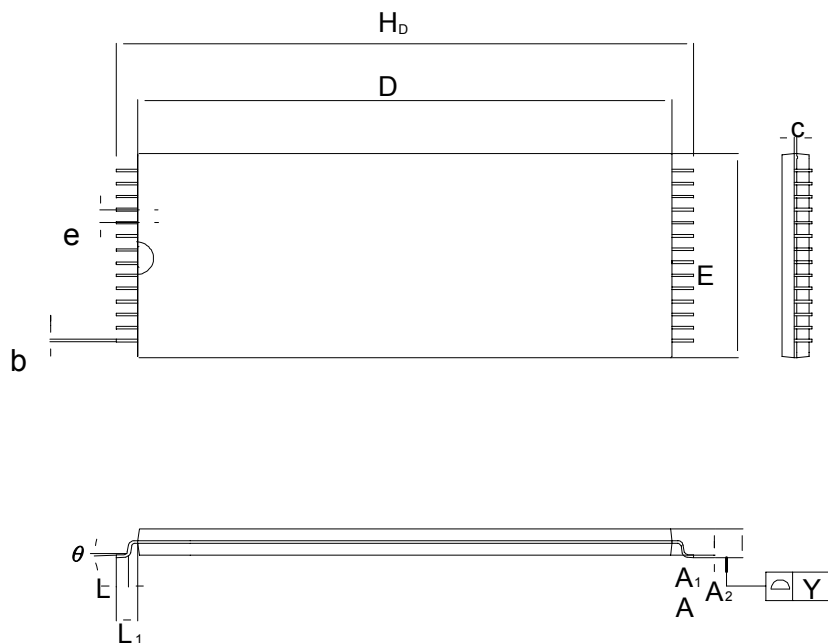

Symbol	Dimension in Inches			Dimension in mm		
	Min.	Nom.	Max.	Min.	Nom.	Max.
A	—	—	0.047	—	—	1.20
A <sub>1</sub>	0.002	—	0.006	0.05	—	0.15
A <sub>2</sub>	0.035	0.040	0.041	0.95	1.00	1.05
b	0.007	0.008	0.011	0.17	0.20	0.27
c	0.004	0.006	0.008	0.10	0.15	0.21
D	0.461	0.465	0.469	11.70	11.80	11.90
E	0.311	0.315	0.319	7.90	8.00	8.10
H <sub>b</sub>	0.520	0.528	0.536	13.20	13.40	13.60
e	—	0.022	—	—	0.55	—
L	0.020	0.024	0.028	0.50	0.60	0.70
L <sub>1</sub>	—	0.031	—	—	0.80	—
Y	0.000	—	0.004	0.00	—	0.10
θ	0	3	5	0	3	5

## ISD1720



## 11.2 28-LEAD 300-MIL PLASTIC SMALL OUTLINE INTEGRATED CIRCUIT (SOIC)

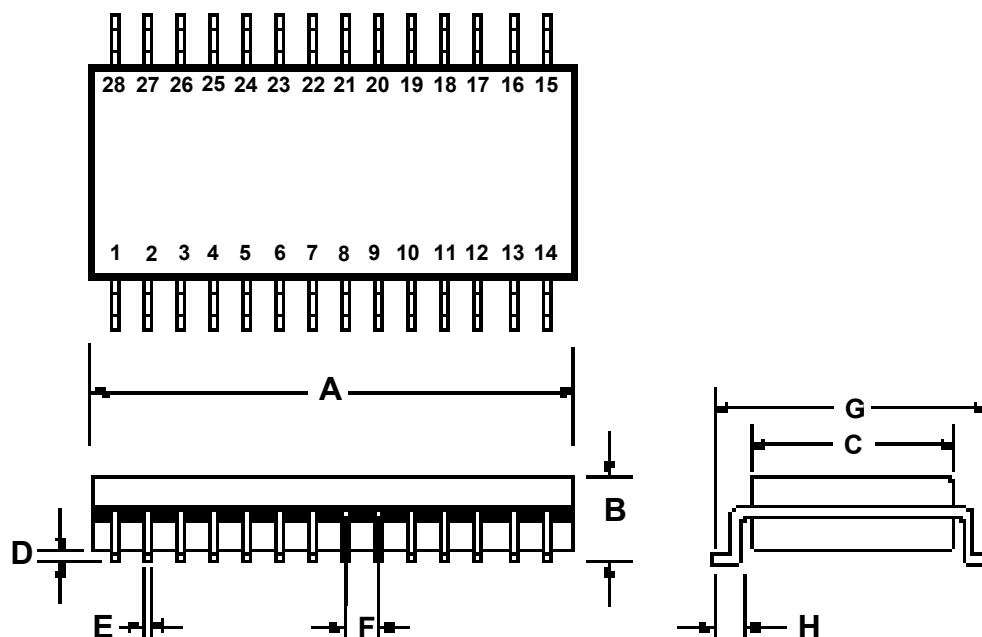

Plastic Small Outline Integrated Circuit (SOIC) Dimensions

	INCHES			MILLIMETERS		
	Min	Nom	Max	Min	Nom	Max
<b>A</b>	0.701	0.706	0.711	17.81	17.93	18.06
<b>B</b>	0.097	0.101	0.104	2.46	2.56	2.64
<b>C</b>	0.292	0.296	0.299	7.42	7.52	7.59
<b>D</b>	0.005	0.009	0.0115	0.127	0.22	0.29
<b>E</b>	0.014	0.016	0.019	0.35	0.41	0.48
<b>F</b>		0.050			1.27	
<b>G</b>	0.400	0.406	0.410	10.16	10.31	10.41
<b>H</b>	0.024	0.032	0.040	0.61	0.81	1.02

**Note:** Lead coplanarity to be within 0.004 inches.

## ISD1720



## 11.3 28-LEAD 600-MIL PLASTIC DUAL INLINE PACKAGE (PDIP)

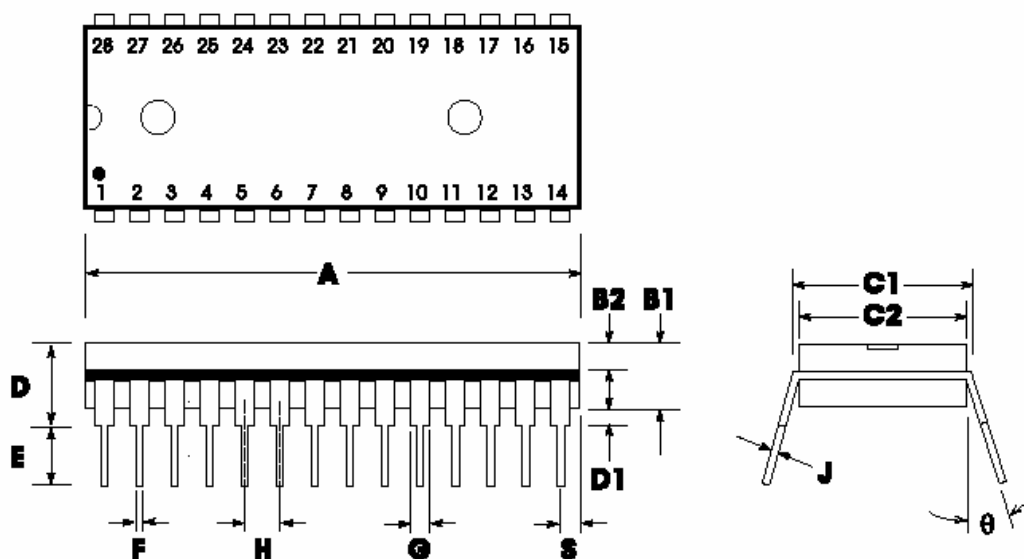

Plastic Dual In-line Package (PDIP) (P) Dimensions

	INCHES			MILLIMETERS		
	Min	Nom	Max	Min	Nom	Max
A	1.445	1.450	1.455	36.70	36.83	36.96
B1		0.150			3.81	
B2	0.065	0.070	0.075	1.65	1.78	1.91
C1	0.600		0.625	15.24		15.88
C2	0.530	0.540	0.550	13.46	13.72	13.97
D			0.19			4.83
D1	0.015			0.38		
E	0.125		0.135	3.18		3.43
F	0.015	0.018	0.022	0.38	0.46	0.56
G	0.055	0.060	0.065	1.40	1.52	1.65
H		0.100			2.54	
J	0.008	0.010	0.012	0.20	0.25	0.30
S	0.070	0.075	0.080	1.78	1.91	2.03
θ	0°		15°	0°		15°

## 11.4 DIE INFORMATION

For die info, please contact the local Winbond Sales Representatives.

Publication Release Date: April 4, 2007  
Revision 0

## ISD1720



## 12 ORDERING INFORMATION

## Product Number Descriptor Key

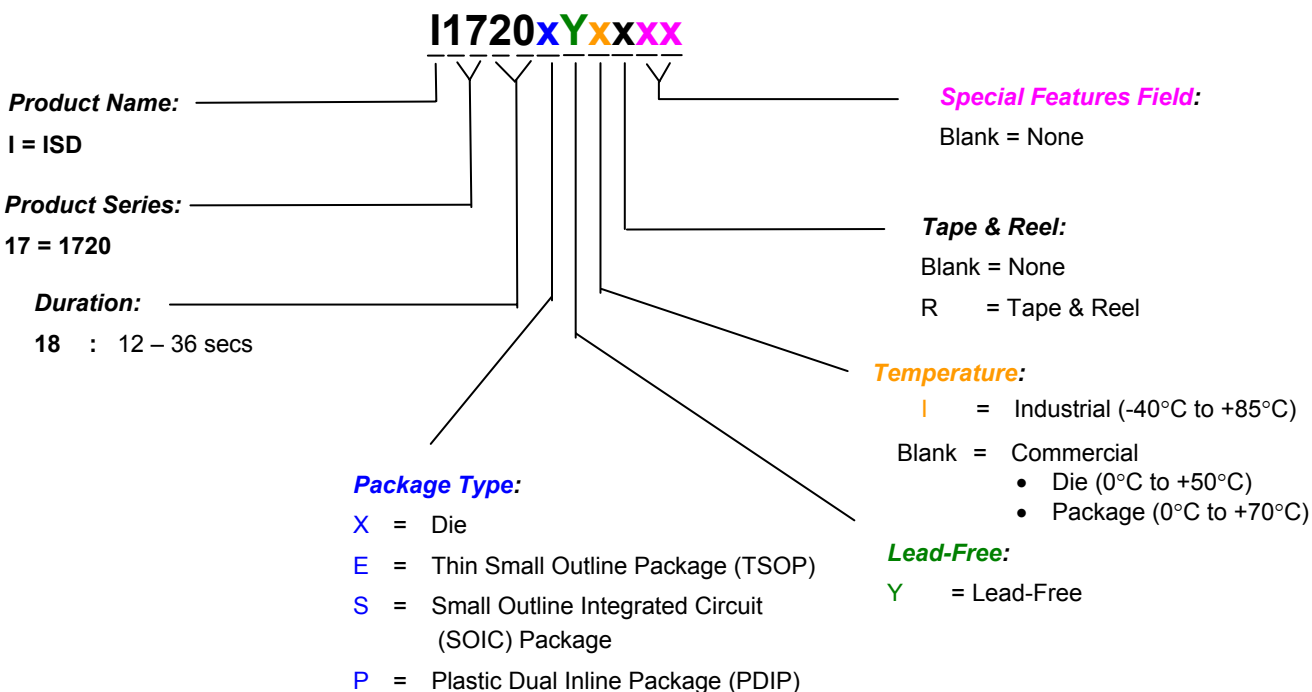

When ordering ISD1720 device, please refer to the above ordering scheme. Contact the local Winbond Sales Representatives for any questions and the availability.

For the latest product information, please contact the Winbond Sales/Rep or access Winbond's worldwide web site at <http://www.winbond-usa.com>

## ISD1720

**13 VERSION HISTORY**

<b>VERSION</b>	<b>DATE</b>	<b>DESCRIPTION</b>
0	Apr 2007	Initial version

## ISD1720



Winbond products are not designed, intended, authorized or warranted for use as components in systems or equipment intended for surgical implantation, atomic energy control instruments, airplane or spaceship instruments, transportation instruments, traffic signal instruments, combustion control instruments, or for other applications intended to support or sustain life. Furthermore, Winbond products are not intended for applications wherein failure of Winbond products could result or lead to a situation wherein personal injury, death or severe property or environmental damage could occur.

Winbond customers using or selling these products for use in such applications do so at their own risk and agree to fully indemnify Winbond for any damages resulting from such improper use or sales.

The contents of this document are provided only as a guide for the applications of Winbond products. Winbond makes no representation or warranties with respect to the accuracy or completeness of the contents of this publication and reserves the right to discontinue or make changes to specifications and product descriptions at any time without notice. No license, whether express or implied, to any intellectual property or other right of Winbond or others is granted by this publication. Except as set forth in Winbond's Standard Terms and Conditions of Sale, Winbond assumes no liability whatsoever and disclaims any express or implied warranty of merchantability, fitness for a particular purpose or infringement of any Intellectual property.

The contents of this document are provided "AS IS", and Winbond assumes no liability whatsoever and disclaims any express or implied warranty of merchantability, fitness for a particular purpose or infringement of any Intellectual property. In no event, shall Winbond be liable for any damages whatsoever (including, without limitation, damages for loss of profits, business interruption, loss of information) arising out of the use of or inability to use the contents of this documents, even if Winbond has been advised of the possibility of such damages.

Application examples and alternative uses of any integrated circuit contained in this publication are for illustration only and Winbond makes no representation or warranty that such applications shall be suitable for the use specified.

The 100-year retention and 100K record cycle projections are based upon accelerated reliability tests, as published in the Winbond Reliability Report, and are neither warranted nor guaranteed by Winbond. This product incorporates SuperFlash®.

This datasheet and any future addendum to this datasheet is(are) the complete and controlling ISD® ChipCorder® product specifications. In the event any inconsistencies exist between the information in this and other product documentation, or in the event that other product documentation contains information in addition to the information in this, the information contained herein supersedes and governs such other information in its entirety. This datasheet is subject to change without notice.

Copyright© 2005, Winbond Electronics Corporation. All rights reserved. ChipCorder® and ISD® are trademarks of Winbond Electronics Corporation. SuperFlash® is the trademark of Silicon Storage Technology, Inc. All other trademarks are properties of their respective owners.

**Headquarters**

No. 4, Creation Rd. III  
Science-Based Industrial Park,  
Hsinchu, Taiwan  
TEL: 886-3-5770066  
FAX: 886-3-5665577  
<http://www.winbond.com.tw/>

**Winbond Electronics Corporation America**

2727 North First Street, San Jose,  
CA 95134, U.S.A.  
TEL: 1-408-9436666  
FAX: 1-408-5441797  
<http://www.winbond-usa.com/>

**Winbond Electronics (Shanghai) Ltd.**

27F, 299 Yan An W. Rd. Shanghai,  
200336 China  
TEL: 86-21-62365999  
FAX: 86-21-62356998

**Taipei Office**

9F, No. 480, Pueiguan Rd.  
Neihu District  
Taipei, 114 Taiwan  
TEL: 886-2-81777168  
FAX: 886-2-87153579

**Winbond Electronics Corporation Japan**

7F Daini-ueno BLDG. 3-7-18  
Shinyokohama Kohokuku,  
Yokohama, 222-0033  
TEL: 81-45-4781881  
FAX: 81-45-4781800

**Winbond Electronics (H.K.) Ltd.**

Unit 9-15, 22F, Millennium City,  
No. 378 Kwun Tong Rd.,  
Kowloon, Hong Kong  
TEL: 852-27513100  
FAX: 852-27552064

Please note that all data and specifications are subject to change without notice.  
All the trademarks of products and companies mentioned in this datasheet belong to their respective owners.