

182-005
Fiber Optic Polishing Tool
 for 181-011 and 181-012 Front Release Termini



182-005 S W

Product Series ———
 Basic Number ———
 Designation Symbol ———

S = Socket Terminus
 P = Pin terminus

W = Wet Polish Supplied
 with V-Grooves
 (Omit for Dry Polish)

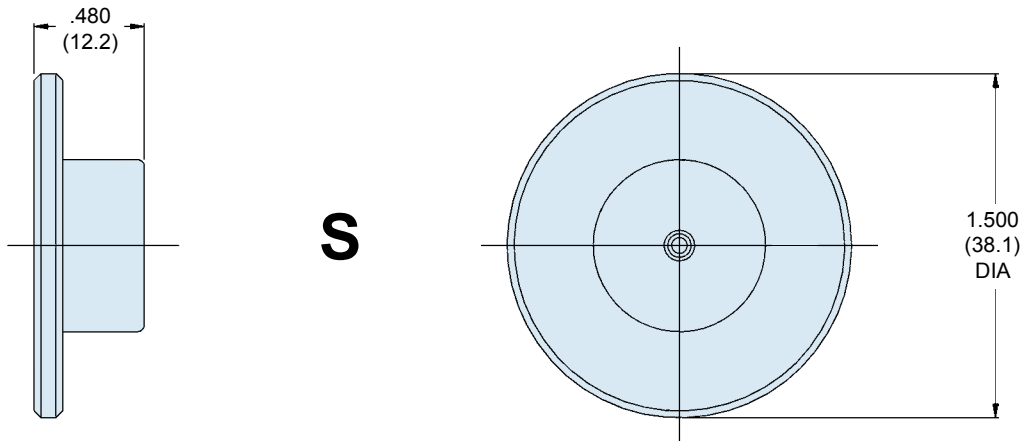
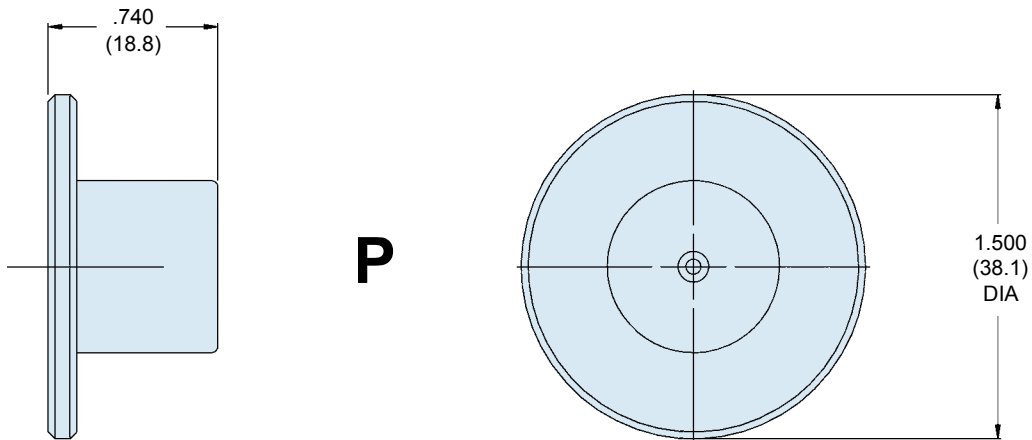

APPLICATION NOTES

1. Assembly packaged in plastic bag and tag identified with manufacturer's name and part number.
2. Assembly marked with "PIN" or "SKT" and part number.
3. Material/Finish: Stainless Steel/Passivated.
4. Metric Dimensions (mm) are indicated in parentheses.