

FCX - C II PRESSURE TRANSMITTER

DATA SHEET

FKP...4

The FCX -C II pressure transmitter accurately measures gauge pressure and transmits proportional 4 to 20mA signal.

The transmitter utilizes the unique micromachined capacitive silicon sensor with state-of-the-art microprocessor technology to provide exceptional performance and functionality.

FEATURES

1. **High accuracy ±0.1%**
0.1% accuracy is a standard feature. Fuji's micro-capacitance silicon sensor assures this accuracy for all elevated or suppressed calibration ranges without additional adjustment.
2. **Minimum environmental influence**
The "Advance Floating Cell" design which protects the pressure sensor against changes in temperature, and overpressure substantially reduces total measurement error in actual field applications.
3. **Fuji/HART® bilingual communications protocol and FOUNDATION™ fieldbus and Profibus™ compatibility**
FCX-C II series transmitter offers bilingual communications to speak both Fuji proprietary protocol and HART®. Any HART® compatible devices can communicate with FCX-C II. Further, by upgrading electronics FOUNDATION™ fieldbus and Profibus™ are also available.
4. **Application flexibility**
Various options that render the FCX - C II suitable for almost any process applications include:
 - Analog indicator at either the electronics side or terminal side
 - Full range of hazardous area approvals
 - Built-in RFI filter and lightning arrester
 - 5-digit LCD meter with engineering unit
5. **Burnout current flexibility (Under Scale: 3.2 to 3.8mA, Over Scale: 20.8 to 21.6mA)**
Burnout signal level is adjustable using Model FXW Hand Held Communicator (HHC) to comply with NAMUR NE43.
6. **Dry calibration without reference pressure**
Thanks to the best combination of unique construction of mechanical parts (Sensor unit) and high performance electronics circuit (Electronics unit), reliability of dry calibration without reference pressure is at equal level as wet calibration.



SPECIFICATIONS

Functional specifications

Service: Liquid, gas, or vapour
Span, range and overrange limit:

Type	Span limit [kPa] {bar}		Range limit [kPa] {bar}	Overrange limit [MPa] {bar}
	Min.	Max.		
FKP□01	8.125 {0.08125}	130 {1.3}	-100 to +130 {-1 to +1.3}	1 {10}
FKP□02	31.25 {0.3125}	500 {5}	-100 to +500 {-1 to +5}	1.5 {15}
FKP□03	187.5 {1.875}	3000 {30}	-100 to +3000 {-1 to +30}	9 {90}
FKP□04	625 {6.25}	10000 {100}	-100 to +10000 {-1 to + 100}	15 {150}

- Lower range limit (vacuum limit) is;
Silicone fill sensor: See Fig. 1
Fluorinated fill sensor: 66kPa abs (500mmHg abs) at below 80°C
- Conversion factors to different units;
1 MPa=10³ KPa=10bar=10.19716kgf/cm²= 145.0377psi
1 KPa=10mbar=101.9716mmH₂O =4.01463inH₂O
- Output signal:** 4 to 20mA DC with digital signal superimposed on the 4 to 20mA signal.

Power supply: Transmitter operates on 10.5V to 45V DC at transmitter terminals.
10.5V to 32V DC for the units with optional arrester.

Load limitations: see figure below

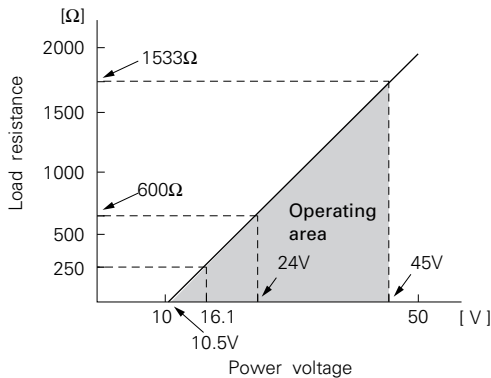

Note: For communication with HHC⁽¹⁾ (Model: FXW), min. of 250 Ω required.

Hazardous locations: (Approval pending)

Authorities	Flameproof
ATEX	Ex II 2 GD EEx d IIC T6 IP66/67 T85°C Tamb = -40°C to +65°C EEx d IIC T5 IP66/67 T100°C Tamb = -40°C to +85°C
Factory Mutual	Class I Div.1 Groups B, C, D T6 Type 4X Class II III Div.1 Groups E, F, G T6 Type 4X Tamb max = +60°C
CSA	Class I Div.1 Groups C, D Class II Div.1 Groups E, F, G Class III Div.1 Note) "Seal Not Required" enclosure is allowed.
IECEX Scheme /SAA	Ex d IIC T5 IP66/67 pending Tamb = -40°C to +85°C Ex d IIC T6 IP66/67 pending Tamb = -40°C to +65°C

Authorities	Intrinsic safety																					
ATEX	Ex II 1 GD EEx ia IIC T5 Tamb = -40°C to +40°C EEx ia IIC T4 Tamb = -40°C to +80°C Entity Parameters: Ui=28V, Ii=93.3mA, Pi=0.66W, Ci=27nF (Without Arrester), Ci=34.2nF (With Arrester), Li=1.134mH																					
Factory Mutual	Class I II III Div.1 Groups A, B, C, D, E, F, G T4 Entity Type 4X <table border="1"> <thead> <tr> <th colspan="2">Model code</th> <th>Tamb</th> </tr> <tr> <th>9th digit</th> <th>13th digit</th> <th></th> </tr> </thead> <tbody> <tr> <td>A,B,D</td> <td>Y,G,N</td> <td>-40°C to +85°C</td> </tr> <tr> <td>L,P,1,2</td> <td>Y,G,N</td> <td>-20°C to +80°C</td> </tr> <tr> <td>Q,S,4,5</td> <td>Y,G,N</td> <td>-20°C to +60°C</td> </tr> <tr> <td>E,F,H</td> <td>Y,G,N</td> <td>-40°C to +60°C</td> </tr> <tr> <td>-</td> <td>A</td> <td>-10°C to +60°C</td> </tr> </tbody> </table> Entity Parameters: Vmax=42.4V, Imax=113mA, Pi=1W, Ci=34.2nF, Li=1.134mH	Model code		Tamb	9th digit	13th digit		A,B,D	Y,G,N	-40°C to +85°C	L,P,1,2	Y,G,N	-20°C to +80°C	Q,S,4,5	Y,G,N	-20°C to +60°C	E,F,H	Y,G,N	-40°C to +60°C	-	A	-10°C to +60°C
Model code		Tamb																				
9th digit	13th digit																					
A,B,D	Y,G,N	-40°C to +85°C																				
L,P,1,2	Y,G,N	-20°C to +80°C																				
Q,S,4,5	Y,G,N	-20°C to +60°C																				
E,F,H	Y,G,N	-40°C to +60°C																				
-	A	-10°C to +60°C																				
CSA	Class I Div.1 Groups A, B, C, D Class II Div.1 Groups E, F, G Class III Div.1 Temp Code T4 Tamb max = +40°C Temp Code T3C Tamb max = +85°C Entity Parameters: Vmax=28V, Imax=93mA, Ci=27nF (Without Arrester), Ci=34.2nF (With Arrester), Li=1.4mH																					
IECEX Scheme /SAA	Ex ia IIC T4 IP66/67 Tamb = -40°C to +70°C Ex ia IIC T5 IP66/67 Tamb = -40°C to +50°C Entity Parameter: Ui=28V, Ii=93.3mA, Pi=0.66W, Ci=0.033μF, Li=1.034mH																					

Authorities	Type n Nonincendive																				
ATEX	Ex II 3 GD EEx nL IIC T5 Tamb = -40°C to +40°C EEx nL IIC T4 Tamb = -40°C to +80°C Specific Parameters: Model without arrester: Ui=42.4V, Ii=113mA, Pi=1W, Ci=27nF, Li=1.134mH Model with arrester: Ui=32V, Ii=113mA, Pi=1W, Ci=34.2nF, Li=1.134mH EEx nAL IIC T5 Tamb = -40°C to +40°C EEx nAL IIC T4 Tamb = -40°C to +80°C Specific Parameters: Model without arrester: Umax=42.4V, Imax=113mA, Pmax=1W, Model with arrester: Umax=32V, Imax=113mA, Pmax=1W																				
Factory Mutual	Class I II III Div.2 Groups A, B, C, D, F, G T4 Entity Type 4X <table border="1"> <thead> <tr> <th colspan="2">Model code</th> <th rowspan="2">Tamb</th> </tr> <tr> <th>9th digit</th> <th>13th digit</th> </tr> </thead> <tbody> <tr> <td>A,B,D</td> <td>Y,G,N</td> <td>-40°C to +85°C</td> </tr> <tr> <td>L,P,1,2</td> <td>Y,G,N</td> <td>-20°C to +80°C</td> </tr> <tr> <td>Q,S,4,5</td> <td>Y,G,N</td> <td>-20°C to +60°C</td> </tr> <tr> <td>E,F,H</td> <td>Y,G,N</td> <td>-40°C to +60°C</td> </tr> <tr> <td>-</td> <td>A</td> <td>-10°C to +60°C</td> </tr> </tbody> </table>	Model code		Tamb	9th digit	13th digit	A,B,D	Y,G,N	-40°C to +85°C	L,P,1,2	Y,G,N	-20°C to +80°C	Q,S,4,5	Y,G,N	-20°C to +60°C	E,F,H	Y,G,N	-40°C to +60°C	-	A	-10°C to +60°C
Model code		Tamb																			
9th digit	13th digit																				
A,B,D	Y,G,N	-40°C to +85°C																			
L,P,1,2	Y,G,N	-20°C to +80°C																			
Q,S,4,5	Y,G,N	-20°C to +60°C																			
E,F,H	Y,G,N	-40°C to +60°C																			
-	A	-10°C to +60°C																			
CSA	Class I Div.2 Groups A, B, C, D Class II Div.2 Groups E, F, G Class III Div.2 Temp Code T4 Tamb max = +40°C Temp Code T3C Tamb max = +85°C Entity Parameters: Vmax=28V, Ci=27nF (Without Arrester), Ci=34.2nF (With Arrester), Li=1.4mH																				
IECEx Scheme /SAA	-																				

Zero/span adjustment:

Zero and span are adjustable from the HHC⁽¹⁾. Zero and span are also adjustable externally from the adjustment screw (span adjustment not available with 9th digit code "L, P, Q, S").

Damping:

Adjustable from HHC or local adjustment unit with LCD display.

The time constant is adjustable between 0.12 to 32 seconds.

Zero elevation/suppression:

Zero can be elevated or suppressed within the specified range limit of each sensor model.

Normal/reverse action:

Selectable from HHC⁽¹⁾.

Indication:

Analog indicator or 5-digit LCD meter, as specified.

Burnout direction: Selectable from HHC⁽¹⁾

If self-diagnostic detect transmitter failure, the analog signal will be driven to either "Output Hold", "Output Overscale" or "Output Underscale" modes.

"Output Hold":

Output signal is hold as the value just before failure happens.

"Output Overscale":

Adjustable within the range 20.8mA to 21.6mA from HHC⁽¹⁾

"Output Underscale":

Adjustable within the range 3.2mA to 3.8mA from HHC

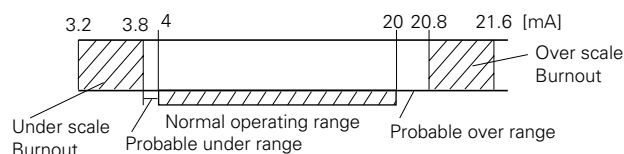

(Note) (1) HHC: Hand Held Communicator

Loop-check output:

Transmitter can be configured to provide constant signal 3.8mA through 21.6mA by HHC.

Temperature limit:

Ambient: -40 to +85°C
 (-20 to +80°C for LCD indicator)
 (-40 to +60°C for arrester option)
 (-10 to +60°C for fluorinated oil fill transmitter)
 For explosionproof units (flameproof or intrinsic safety), ambient temperature must be within the limits specified by each standard.

Process: -40 to +100°C for silicone fill sensor
 -20 to +80°C for fluorinated oil fill sensor

Storage: -40 to +90°C

Humidity limit:

0 to 100% RH

Communication:

With HHC⁽¹⁾ (Model FXW, consult Data Sheet No. EDS8-47), following information can be remotely displayed or reconfigured.

Note: HHC's version must be more than 6.0 (or FXW □□□□1-□3), for FCX-C II.

Items	Display	Set
Tag No.	✓	✓
Model No.	✓	✓
Serial No.	✓	—
Engineering unit	✓	✓
Range limit	✓	—
Measuring range	✓	✓
Damping	✓	✓
Output mode	✓	—
Burnout direction	✓	✓
Calibration	✓	✓
Output adjust	—	✓
Data	✓	—
Self diagnoses	✓	—
Printer	—	—
External switch lock	✓	✓
Transmitter display	✓	✓
Linearize	✓	✓
Rerange	✓	✓

(Note) (1) HHC: Hand Held Communicator

Performance specifications

- Accuracy rating:** (including linearity, hysteresis, and repeatability)
 For spans greater than 1/10 of URL:
 $\pm 0.1\%$ of span
 For spans below 1/10 of URL (Model FKP only):
 $\pm (0.05 + 0.05 \frac{0.1 \times \text{URL}}{\text{span}}) \% \text{ of span}$
- Stability:** $\pm 0.1\%$ of upper range limit (URL) for 6 months
- Temperature effect:**
 Effects per 55°C change between the limits of -40°C and +85°C
 Zero shift :
 $\pm (0.1 \frac{\text{URL}}{\text{span}}) \% / 28^\circ\text{C}$
 Total effect:
 $\pm (0.075 + 0.1 \frac{\text{URL}}{\text{span}}) \% / 28^\circ\text{C}$
- Overrange effect:** Zero shift, 0.3% of URL for any overrange to maximum limit
- Supply voltage effect:**
 Less than 0.05% fo calibrated span per 10V
- RFI effect:** Less than 0.2% of URL for the frequencies of 20 to 1000MHz and field strength 30 V/m when electronics covers on.
 (Classification: 2-abc: 0.2% span per SAMA PMC 33.1)
- Update period:** 120 msec
- Step response:** Time constant: 0.2s
 Dead time: about 0.2s
 (without electrical damping)
- Mounting position effect:**
 Zero shift, less than 0.1kPa {1mbar} for a 10° tilt in any plane.
 No effect on span. This error can be corrected by adjusting zero.
 (Double the effect for fluorinated fill sensors)
- Dielectric strength:**
 500V AC, 50/60Hz 1 min., between circuit and earth
- Insulation resistance:**
 More than 100MΩ at 500V DC
- Turn-on time:** 4 sec.
- Internal resistance for external field indicator:**
 12Ω or less.

Physical specifications

- Electrical connections:**
 G1/2, 1/2-14 NPT, Pg13.5, or M20×1.5 conduit, as specified.
- Process connections:**
 1/2-14NPT, Rc1/2, Rc1/4 or 1/4-18NPT, as specified.
- Process-wetted parts material:**
- | Material code (7th digit in Code symbols) | Process cover | Diaphragm | Wetted sensor body |
|---|---------------------|----------------------|---------------------|
| V | 316 stainless steel | 316L stainless steel | 316 stainless steel |
- Non-wetted parts material:**
 Electronics housing: Low copper die-cast aluminum alloy (standard), finished with epoxy/polyurethane double coating.
 Fill fluid: Silicone oil (standard) or fluorinated oil (Daifloil)
 Mounting bracket: 304 stainless steel
- Environmental protection:**
 IEC IP67 and NEMA 6/6P
- Mounting:**
 On 60.5mm (JIS 50A or 2B) pipe using mounting bracket, direct wall mounting, or direct process mounting.
- Mass{weight}:**
 Transmitter approximately 1.9kg without options.
 Add; 0.5kg for mounting bracket
 0.8kg for indicator option

Optional features

- Indicator:** A plug-in turnable analog indicator (1.5% accuracy) can be housed in the electronics compartment or in the terminal box of the housing.
An optional 5digits LCD meter with engineering unit is also available.
- Local adjustment unit with LCD display:** An optional 5-digit LCD meter with Zero/ Span adjustment function, loop-check function and damping adjustment function, is available.
- Arrester:** A built-in arrester protects the electronics from lightning surges.
Lightning surge immunity:
4kV (1.2 x 50 μs)
- Oxygen service:** Special cleaning procedures are followed throughout the process to maintain all process wetted parts oil-free.
The fill fluid is fluorinated oil.
- Degreasing:** Process-wetted parts are cleaned, but the fill fluid is standard silicone oil. Not for use for oxygen or chlorine measurement.
- NACE specification:** Metallic materials for all pressure boundary parts comply with NACE MR-01-75.
- Optional tag plate:** An extra stainless steel tag with customer tag data is wired to the transmitter.

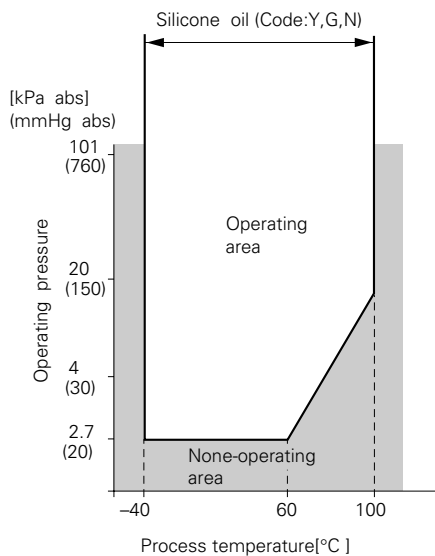

Fig. 1 Relation between process temperature and operating pressure

ACCESSORIES

- Hand-held communicator:** (Model FXW, refer to Data Sheet No. EDS8-47)
- Z/S board:** Parts No.=ZZPFCX4-A070
When Z/S board is mounted on the FCX-C II amplifier unit, external adjustment screw will be available for zero and span adjustment.

The product conforms to the requirements of the Electromagnetic compatibility Directive 94/9/EC as detailed within the technical construction file number TN513035. The applicable standards used to demonstrate compliance are :

**EMI (Emission) EN61326 : 1997
Class A (standard for Industrial Location)**

Frequency range MHz	Limits	Reference standard
30 to 230	40dB (μV/m) quasi peak, measured at 10m distance	CISPR16-1 and CISPR16-2
230 to 1000	47dB (μV/m) quasi peak, measured at 10m distance	

**EMI (Immunity) EN61326: 1997
Annex A (standard for Industrial Location)**

Phenomenon	Test value	Basic standard	Performance criteria
Electrostatic discharge	4kV (Contact) 8kV (Air)	IEC61000-4-2	B
Electromagnetic field	80 to 1000MHz 10V/m 80%AM (1kHz)	IEC61000-4-3	A
Rated power frequency magnetic field	30A/m 50Hz	IEC61000-4-8	A
Burst	2kV 5kHz	IEC61000-4-4	B
Surge	1.2μs/50μs 1kV (Line to line) 2kV (Line to ground)	IEC61000-4-5	B
Conducted RF	0.15 to 80MHz 3V 80%AM (1kHz)	IEC61000-4-6	A

Note) Definition of performance criteria

A: During testing, normal performance within the specification limits.

B: During testing, temporary degradation, or loss of function or performance which is self-recovering.

CODE SYMBOLS

Digit	Description	Note	1	2	3	4	5	6	7	8	9	10	11	12	13	14	15	← Digit No. of code			
4	<Connections> Process conn. _____ 1/2-14NPT	Conduit conn. G1/2 1/2-14NPT Pg 13.5 M20 x 1.5	F	K	P	0				4								0			
6	 FKP kPa {bar} 8.125 ... 130 {0.08125 ... 1.3} 31.25 ... 500 {0.3125 ... 5} 187.5 ... 3000 {1.875 ... 30} 625 ... 10000 {6.25 ... 100}						1	2	3	4											
7	<Material> Process cover Diaphragm Wetted cell body 316 stainless steel 316L stainless steel 316 stainless steel								V												
9	<Indicator and arrester> Indicator Arrester None None } Analog, 0 to 100% linear scale None } Z/S board Analog, custom scale None } attached. ----- None Yes } Analog, 0 to 100% linear scale Yes } Analog, custom scale Yes } ----- Digital, 0 to 100% linear scale None } Digital, custom scale None } Digital, 0 to 100% linear scale Yes } Digital, custom scale Yes } ----- Digital, 0 to 100% (Local adjustment unit with LCD display) None } Digital, Custom scale None } (Local adjustment unit with LCD display) None } Digital, 0 to 100% (Local adjustment unit with LCD display) Yes } Digital, Custom scale Yes }											A	B	D	E	F	H	L	P	Q	S
10	<Approvals for hazardous locations> None (for ordinary locations) ----- FM, Flameproof (or explosionproof) (Available for 4th code "T") CSA Flameproof (or explosionproof) (Available for 4th digit code "T") ATEX, Flameproof IECEx Scheme/SAA, Flameproof (Approval pending) ----- FM, Intrinsic safety and nonincendive CSA Intrinsic safety and nonincendive ATEX, Intrinsic safety ATEX, Type n IECEx Scheme/SAA, Intrinsic safety											A	D	E	X	R	H	J	K	P	T
11	<Mounting bracket> None Yes (stainless steel)												A	C							
12	<Optional specification> Stainless tag None Yes													Y	B						
13	<Special application and fill fluid> Treatment Filled liquid None (standard) Silicon oil Degreasing Silicon oil Oxygen service Fluorinated oil NACE specification Silicon oil														Y	G	A	N			
14	<Process adaptor> None (1/2 -14NPT) Rc1/4 Rc1/2 1/4-18NPT																				Y A B C

OUTLINE DIAGRAM (Unit:mm)

FASTENER
(IN CASE OF 10TH DIGIT CODE "X")

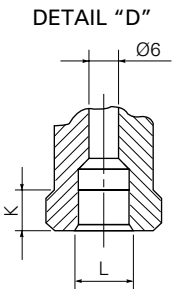
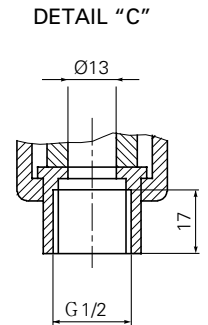
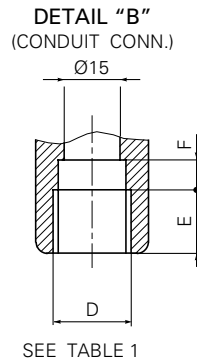
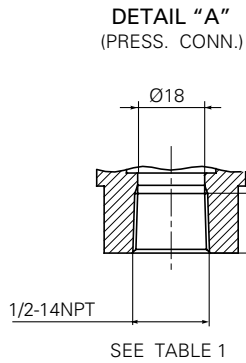
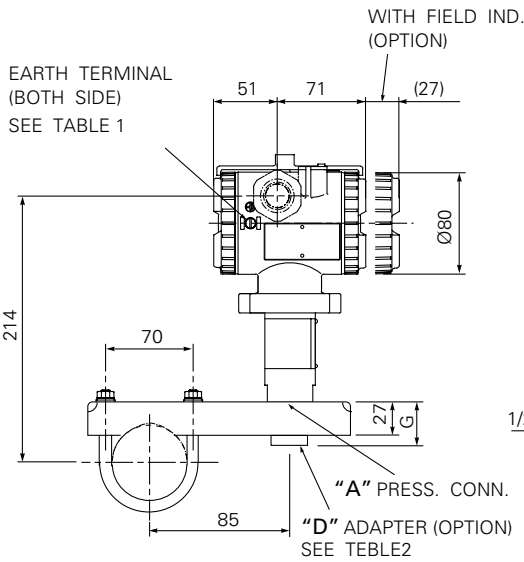
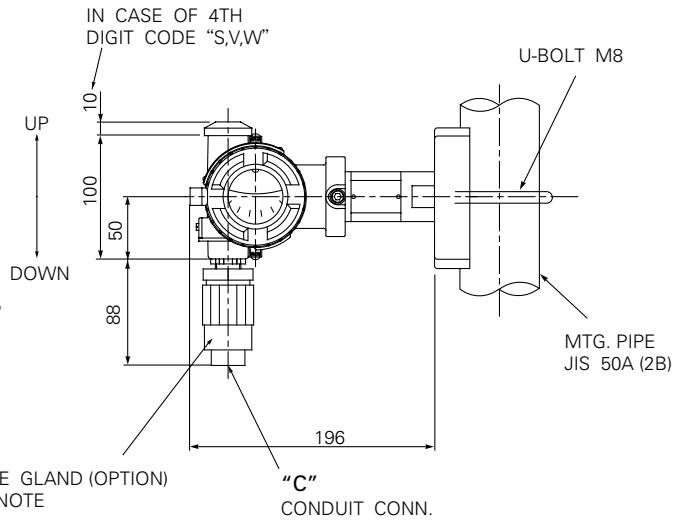
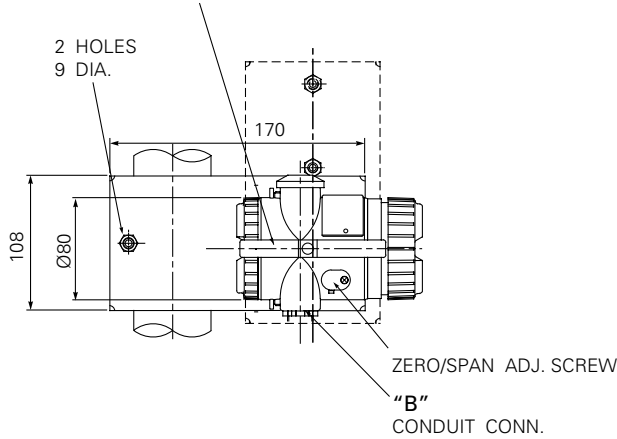

4TH DIGIT CODE	CONDUIT CONN.			EARTH TERMINAL
	D	E	F	
S	G1/2	17	8	M4
T	1/2-14NPT	16	5	M4
V	Pg13.5	8	4.5	M4
W	M20x1.5	16	5	M4

TABLE 1

CONN.	ADAPTER				
	L	G	H	J	K
Rc1/2	44	31	27	16	
NPT1/4 Rc1/4	14	25	22	8	

TABLE 2

HEXAGON SOCKET HEAD
CAP SCREW M4

NOTE) CABLE GLAND IS SUPPLIED IN CASE OF FLAMEPROOF PACKING TYPE.
Ø11 CABLE IS SUITABLE.

CONNECTION DIAGRAMS

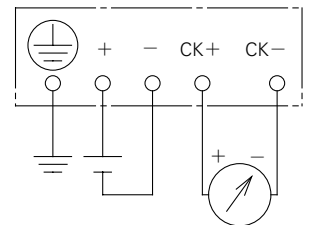

⚠ Caution on Safety

*Before using this product, be sure to read its instruction manual in advance.

Fuji Electric Systems Co., Ltd.

Head Office

Gate City Ohsaki, East Tower, 11-2, Osaki 1-chome,
Shinagawa-ku, Tokyo 141-0032, Japan

<http://www.fesys.co.jp/eng>

Instrumentation Div.

International Sales Dept.

No.1, Fuji-machi, Hino-city, Tokyo, 191-8502 Japan

Phone: 81-42-585-6201, 6202 Fax: 81-42-585-6187

<http://www.fic-net.jp/eng>

Information in this catalog is subject to change without notice.

Printed in Japan