

MAS6011B

Solar Cell Energy Harvesting System Manager

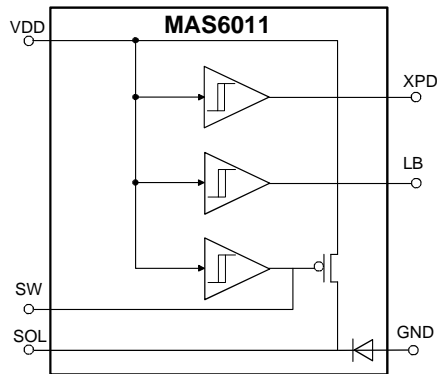

- Ultra Low Power, 110nA
- Low Battery Indicator
- Precise Power Up/Down
- Battery Overcharging Protection

DESCRIPTION

The MAS6011 solar cell system manager monitors the supply voltage and charging of a battery-powered system containing a small solar cell. The current consumption of this IC is extremely low, 110 nA, which means the system can charge from very low light conditions and also stay in power down mode for years and still operate directly from the battery before recharging.

To be able to charge a battery also in condition with very limited light, a large solar cell is usually used. This can on the other hand easily destroy the battery due to over voltage during strong sun light. MAS6011 solves this dilemma and will give secure

protection of a secondary 3V battery over a big range of light strengths (Ix).

Three output signals indicate the state of the system. Power Down (XPD) indicates whether the supply voltage is high enough to power up and run the system. Low Battery (LB) is used to signal the condition when the battery capacity is low and when to move to power saving mode. The third signal, SOL, is used for battery charging control. When the battery is full it bypasses the charging current by an internal shunt switch to avoid overcharging. The SW pin can also be used to control an external shunt switch for higher currents.

FEATURES

- Ultra Low Current Consumption, typ 110nA
- Low Supply Voltage Operation, min 2.0V
- Battery Overcharging Protection
- Power On Indicator and secure Power ON after shut down
- Deep discharge protection of battery during shut down mode
- Precise Shut Down and precise Low Battery warning threshold levels
- Suitable for rechargeable 3V Lithium Vanadium Pentoxide (VL-type) batteries

APPLICATIONS

- Solar Powered Watch
- Solar Powered Wireless Sensor
- Solar Powered Devices with Back-Up
- GPS Modules
- Time Code Receiver modules
- Electronic locks
- Energy Harvesting

FUNCTIONAL DESCRIPTION

The solar manager generates three main signals: XPD (Power Down), LB (Low Battery) and SOL (Solar Charging). The fourth SW signal is for controlling an optional external PMOS transistor.

These signals are produced by three comparators which have hysteresis build in. Each comparator compares the supply voltage (VDD) to the internal switching levels. The current consumption of the comparators is extremely low. The electrical parameters are described more detailed in the Electrical Characteristics chapter.

The XPD signal can be used to power down the whole system whenever the supply voltage level has dropped too low (see application figure 4). When the supply voltage is too low the XPD goes low to power down the solar powered system. When the supply voltage is high enough the XPD goes high controlling power up condition.

For a low power system (max current consumption 1mA) the XPD pin output can be used as a system supply voltage (see application figure 5) to keep the systems current consumption to a minimum.

The LB signal indicates that the battery is low but not empty. It can be used to control the system into a power saving mode. In power on (XPD=high) LB goes high when supply voltage level is too low and LB goes low when supply voltage level is high enough. In power down (XPD=low) the LB is low.

SOL is used for controlling the charging of the rechargeable battery. Normally the internal PMOS switch between VDD and the SOL pin is non-

conductive but when the power supply voltage rises too much this switch is switched on to shunt the solar cell charging current and to prevent battery overcharging. The maximum shunt current capability of the internal PMOS switch is typically 28 mA. If a larger shunt current is needed an external PMOS transistor can be used controlled by the SW pin (see application figure 6).

In operation without an external Schottky diode between the pins SOL and GND, the voltage at pin SOL is clamped to about 700 mV below GND by an internal diode-connected NPN transistor.

MAS6011 does not have any control pin. After the power supply is connected the device is ready to be used.

The XPD, LB and SOL/SW switching levels have been designed for usage with VL-type rechargeable lithium vanadium pentoxide batteries. Those batteries are compact, high energy secondary batteries that have nearly twice the energy of conventional button-shaped Ni-Cd batteries. The self discharge rate is less than 2% a year which makes them very useful as a power source in systems that might be stored for a long time without re-charging.

Figure 1 illustrates the MAS6011 functions and shows the comparator switching levels for both battery charging (rising VDD) and discharging (falling VDD) conditions.

FUNCTIONAL DESCRIPTION

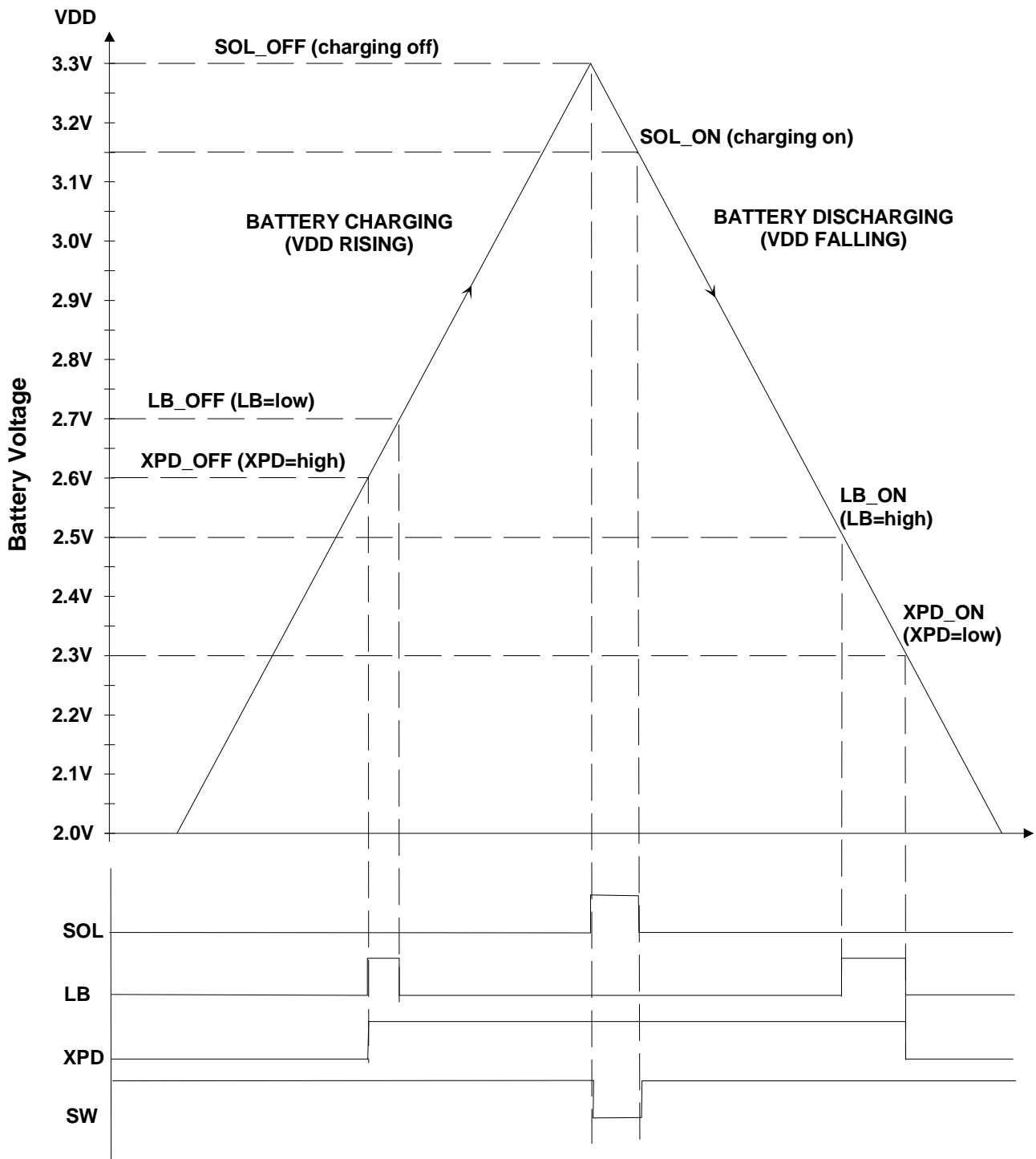

Figure 1. MAS6011 functions

ABSOLUTE MAXIMUM RATINGS

All voltages with respect to ground.

Parameter	Symbol	Conditions	Min	Max	Unit
Supply Voltage	VDD		-0.3	5.5	V
Voltage range for all pins			-0.3	VDD+0.3	V
Operating temperature	T _A		-40	+85	°C
Storage Temperature	T _S		-50	+125	°C

Stresses beyond those listed may cause permanent damage to the device. The device may not operate under these conditions, but it will not be destroyed.

This is a CMOS device and therefore it should be handled carefully to avoid any damage by electrostatic voltages (ESD). The most sensitive pin for the ESD is the SOL pin.

ELECTRICAL CHARACTERISTICS: MAS6011BA1 (3V BATTERY, MCU VDD_{min} ≤ 2.1V)

 Operating Conditions: T_A = -40°C to +85°C, typical values at T_A = +27°C, unless otherwise specified.

Parameter	Symbol	Conditions	Min	Typ	Max	Unit
Supply voltage	VDD		2.0	3.0	3.6	V
Current consumption	I _{DD}	VDD=2V VDD=3V VDD=3.5V	30 50 60	85 110 130	160 200 230	nA
XPD switching level	XPD_OFF XPD_ON	Power Down Off (XPD high) Power Down On (XPD low)	2.40 2.10	2.60 2.30	2.80 2.50	V
XPD hysteresis	V _{XPD(H)}		180	300	600	mV
XPD output voltage	V _{XPD(OUT)}	VDD = 2.1 V, I _{XPD} = -1mA		2.0		V
LB switching level	LB_OFF LB_ON	Low Battery Off (LB low) Low Battery On (LB high)	2.55 2.35	2.70 2.50	2.85 2.65	V
LB hysteresis	V _{LB(H)}		100	200	400	mV
LB output voltage	V _{LB(OUT)}	LB high, I _{LB} = -50 μA LB low, I _{LB} = +50 μA	VDD-0.05		0.05	V
SOL switching level	SOL_OFF SOL_ON	Solar Charging Off Solar Charging On	3.02 2.90	3.30 3.15	3.55 3.40	V
SOL hysteresis	V _{SOL(H)}		50	150	300	mV
SOL sink current	I _{SOL}	VDD = 3.6 V, SOL = 0 V, SOL switch On	19	28	43	mA
SOL leakage current		VDD = 2.9 V	-50		50	nA
LB_OFF – XPD_OFF	V _{LB_XPD_OFF}		10	100	200	mV
LB_ON – XPD_ON	V _{LB_XPD_ON}		100	200	300	mV
SOL_OFF – LB_OFF	V _{SOL_LB_OFF}		200	600	800	mV
SOL_ON – LB_ON	V _{SOL_LB_ON}		350	650	949	mV

TBD = To be defined

ELECTRICAL CHARACTERISTICS: MAS6011BA1 (3V BATTERY, MCU VDD_{min} ≤ 2.1V)

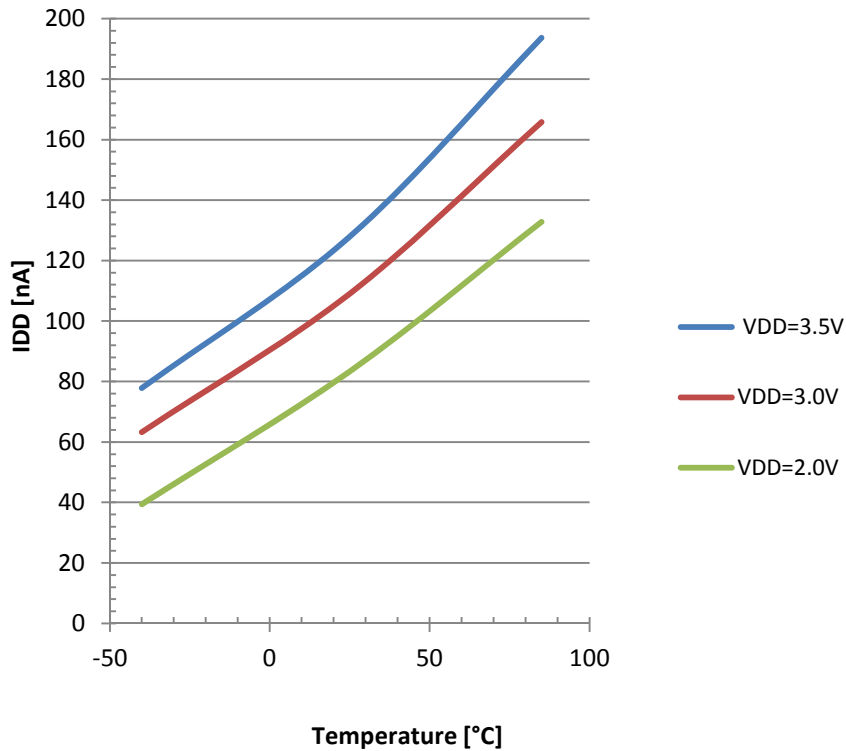

Figure 2. Typical temperature dependency of IDD

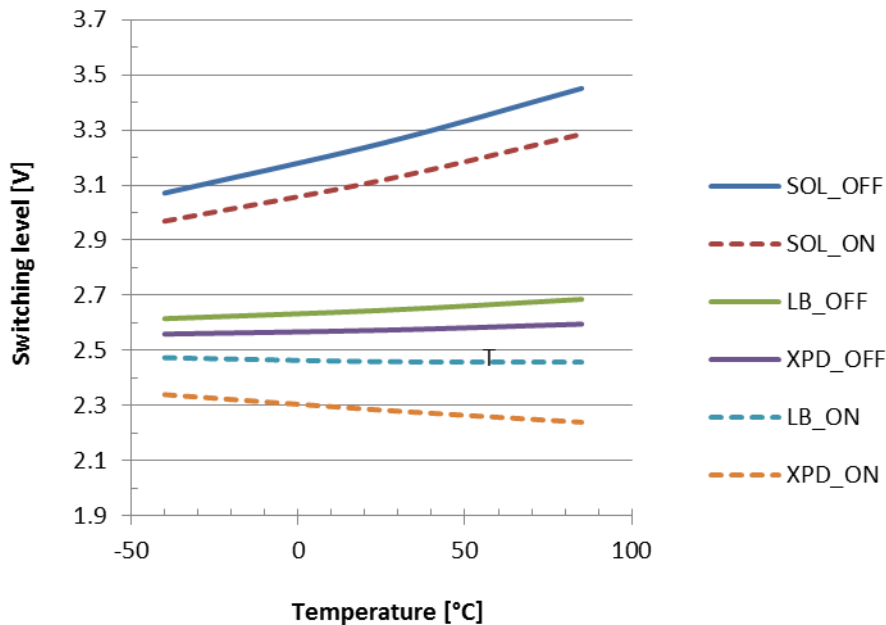

Figure 3. Typical temperature dependency of comparator switching levels

TYPICAL APPLICATION

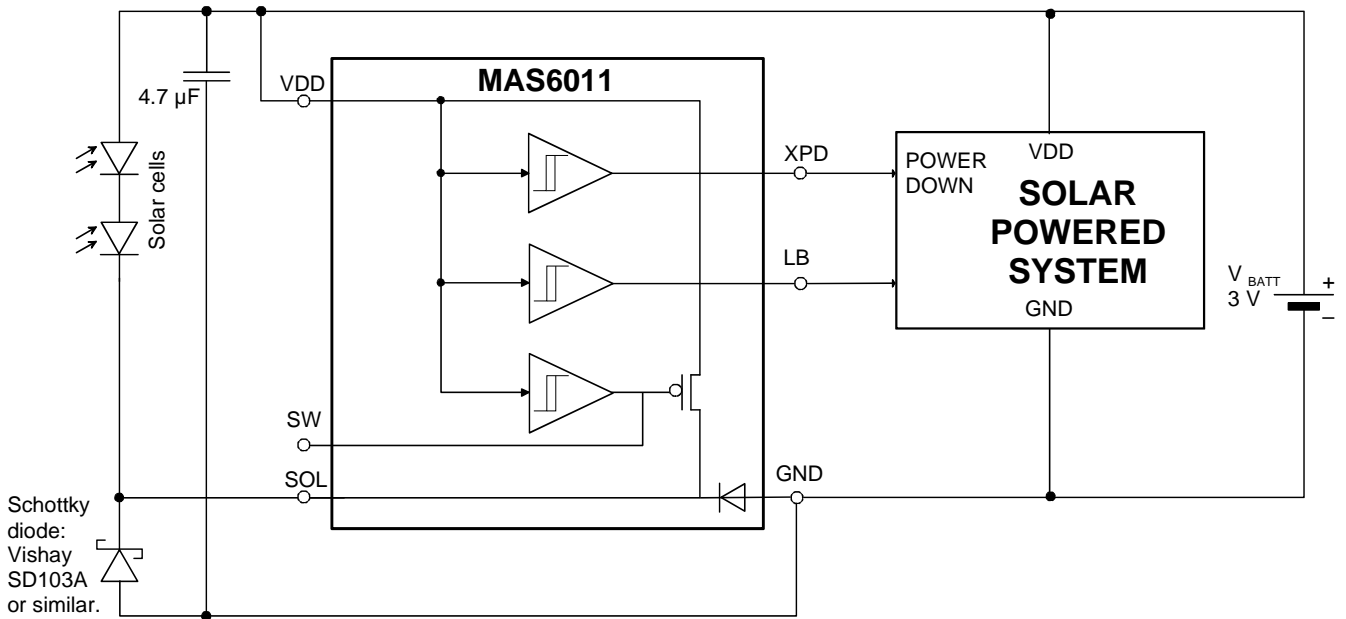

Figure 4. Typical application circuit of MAS6011BA1 – XPD for power down control of solar powered system

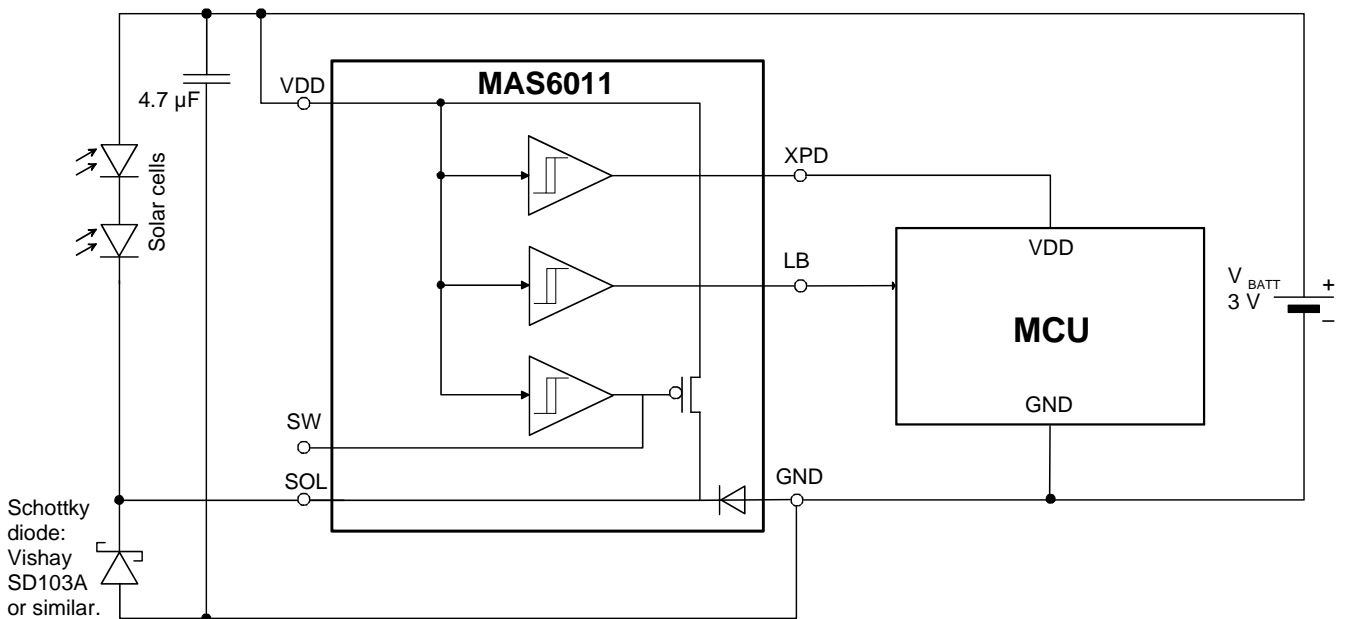

Figure 5. Typical application circuit of MAS6011BA1 – XPD as supply voltage for a low power microcontroller

TYPICAL APPLICATION

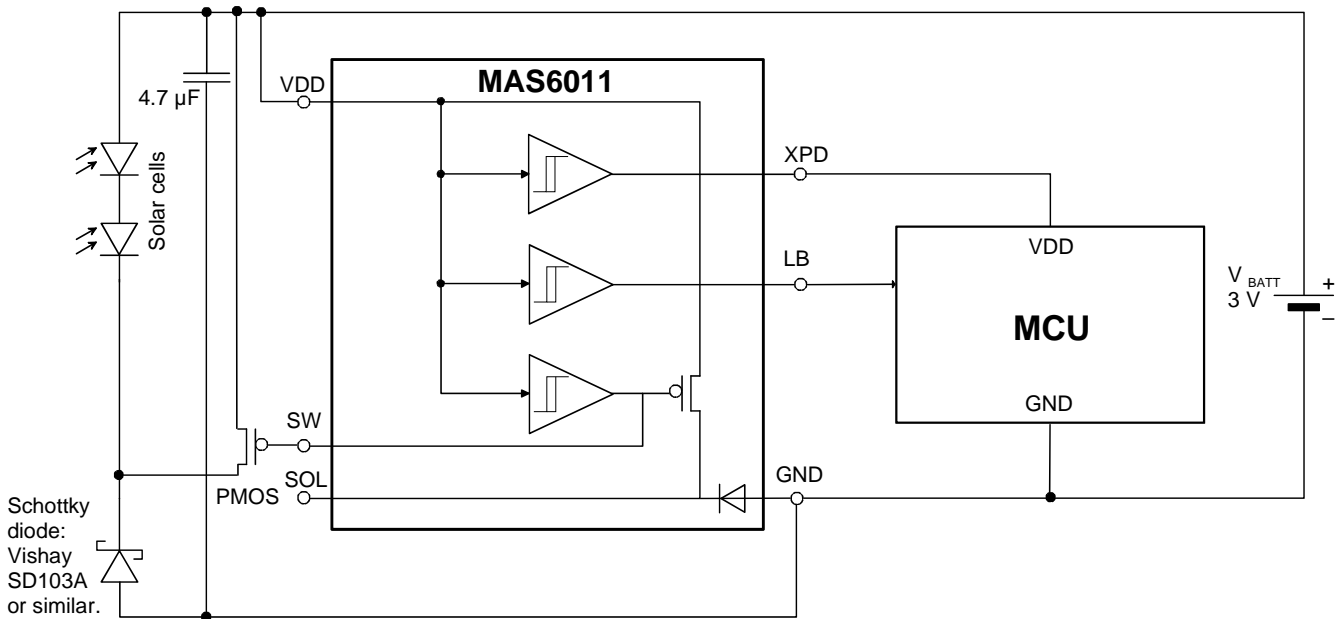

Figure 6. Typical application circuit of MAS6011BA1 – external PMOS transistor shunt for solar current

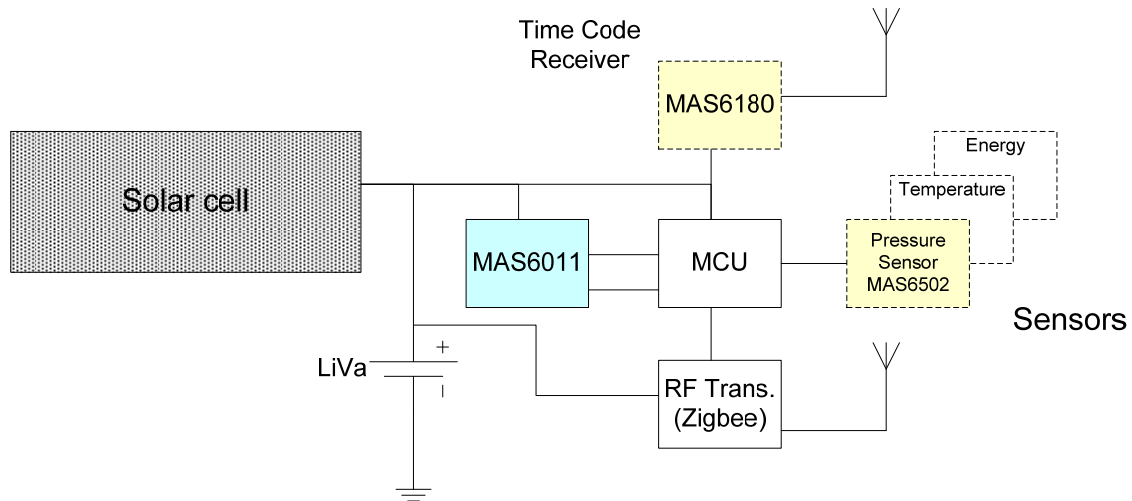

Figure 7. Typical application – Wireless sensor system with Time Code Reception

The system in figure 7 shows a wireless module that can receive both the AM long wave Time Code Signal as well as measuring different physical parameters via several sensors. The information is transmitted via a low power RF transmitter to a receiver indoors. By placing the module where the Time Code signal is strong good reception can be accomplished also in buildings normally blocking this signal. The low power consumption of the MAS6011 together with the energy harvesting solar cell enables this system to operate without the need for battery replacement.

MAS6011BA1 IN QFN 3x3 PACKAGE

QFN 3x3 6ld

GND SW XPD
6 5 4

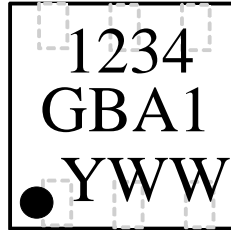

1 2 3
SOL VDD LB

Top Marking Information: 1234 = Product Number, BA1 = Version Number
G = Lead Free, RoHS Compliant Package, YWW = Year Week

QFN 3x3 PIN DESCRIPTION

Pin Name	Pin	Type	Function
SOL	1	AO	Solar Charging Output
VDD	2	P	Positive Power Supply
LB	3	DO	Low Battery Output
XPD	4	DO	Power Down Output
SW	5	DO	External Switch Control Output
GND	6	G	Power Supply Ground

NC = Not Connected, P = Power, G = Ground, DO = Digital Output, AO = Analog Output

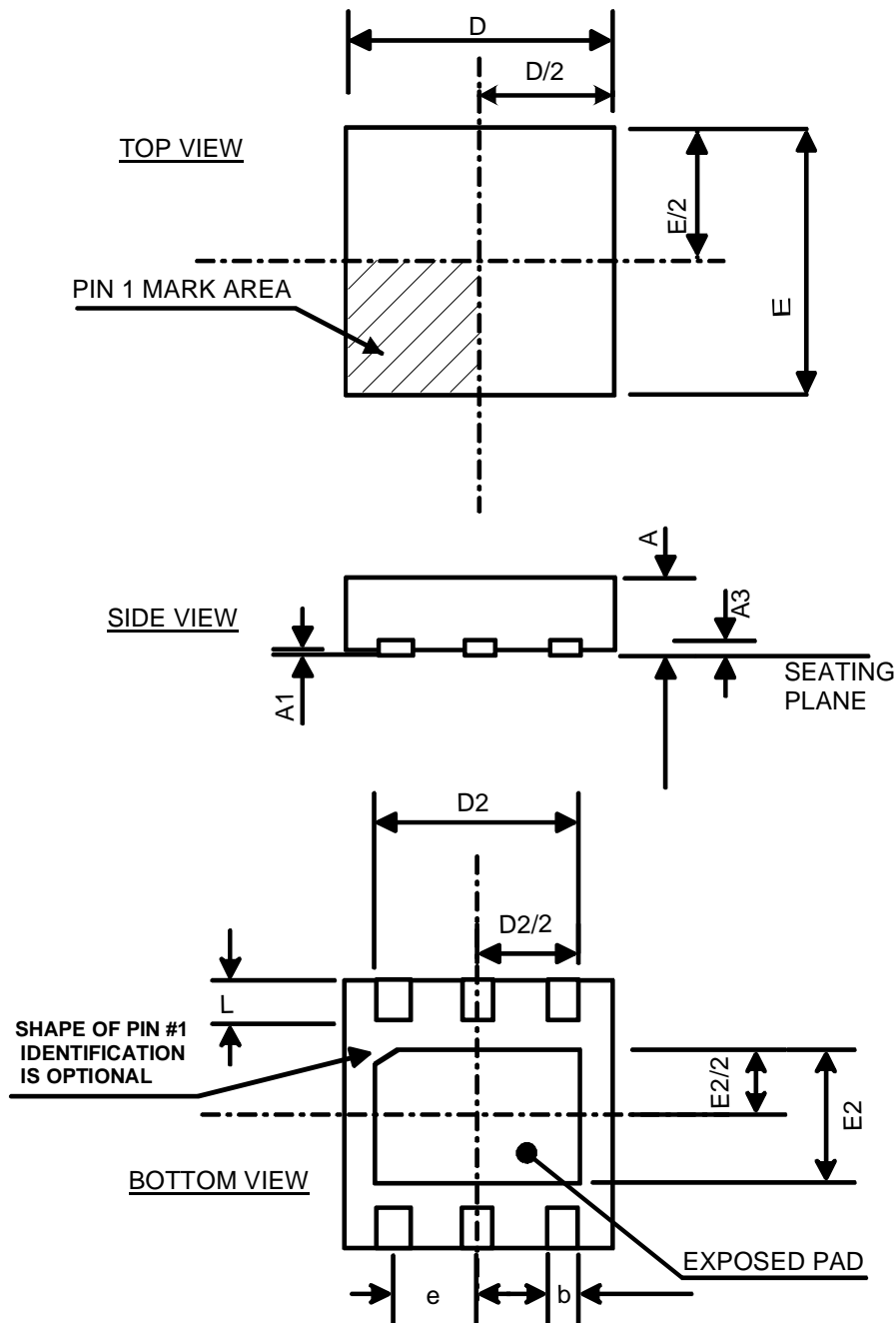
PACKAGE (QFN 3X3x0.75 6ld) OUTLINE

Symbol	Min	Nom	Max	Unit
PACKAGE DIMENSIONS				
A	0.70	0.75	0.80	mm
A1	0.0	0.02	0.05	mm
A3	0.178	0.203	0.228	mm
b	0.350	0.400	0.450	mm
D		3.00 BSC		mm
D2 (Exposed pad)	2.25	2.3	2.35	mm
E		3.00 BSC		mm
E2 (Exposed pad)	1.45	1.5	1.55	mm
e		0.95 BSC		mm
L	0.425	0.475	0.525	mm

Dimensions do not include mold or interlead flash, protrusions or gate burrs.

ORDERING INFORMATION

Product Code	Product	Package	Comments
MAS6011BA1WA305	Solar Cell System Manager (for 3 V rechargeable battery)	400 µm thick dies on tray	
MAS6011BA1Q1306	Solar Cell System Manager (for 3 V rechargeable battery)	QFN 3x3x0.75mm Pb-free RoHS compliant	Tape and Reel

LOCAL DISTRIBUTOR

--

MICRO ANALOG SYSTEMS OY CONTACTS

Micro Analog Systems Oy Kutomotie 16 FI-00380 Helsinki, FINLAND	Tel. +358 10 835 1100 Fax +358 10 835 1109 http://www.mas-oy.com
---	--