



# CY7C401/CY7C403 CY7C402/CY7C404

## 64 x 4 Cascadable FIFO 64 x 5 Cascadable FIFO

### Features

- 64 x 4 (CY7C401 and CY7C403)  
64 x 5 (CY7C402 and CY7C404)  
High-speed first-in first-out memory (FIFO)
- Processed with high-speed CMOS for optimum speed/power
- 25-MHz data rates
- 50-ns bubble-through time—25 MHz
- Expandable in word width and/or length
- 5-volt power supply  $\pm 10\%$  tolerance, both commercial and military
- Independent asynchronous inputs and outputs
- TTL-compatible interface
- Output enable function available on CY7C403 and CY7C404
- Capable of withstanding greater than 2001V electrostatic discharge

- Pin compatible with MMI 67401A/67402A

### Functional Description

The CY7C401 and CY7C403 are asynchronous first-in first-out memories (FIFOs) organized as 64 four-bit words. The CY7C402 and CY7C404 are similar FIFOs organized as 64 five-bit words. Both the CY7C403 and CY7C404 have an output enable (OE) function.

The devices accept 4- or 5-bit words at the data input (DI<sub>0</sub> – DI<sub>n</sub>) under the control of the shift in (SI) input. The stored words stack up at the output (DO<sub>0</sub> – DO<sub>n</sub>) in the order they were entered. A read command on the shift out (SO) input causes the next to last word to move to the output and all data shifts down once in the stack. The input ready (IR) signal acts as a flag to indicate when the input is ready to accept new data (HIGH), to indicate when the FIFO is full (LOW), and to provide a signal for cas-

cading. The output ready (OR) signal is a flag to indicate the output contains valid data (HIGH), to indicate the FIFO is empty (LOW), and to provide a signal for cascading.

Parallel expansion for wider words is accomplished by logically ANDING the IR and OR signals to form composite signals.

Serial expansion is accomplished by tying the data inputs of one device to the data outputs of the previous device. The IR pin of the receiving device is connected to the SO pin of the sending device, and the OR pin of the sending device is connected to the SI pin of the receiving device.

Reading and writing operations are completely asynchronous, allowing the FIFO to be used as a buffer between two digital machines of widely differing operating frequencies. The 25-MHz operation makes these FIFOs ideal for high-speed communication and controller applications.

5

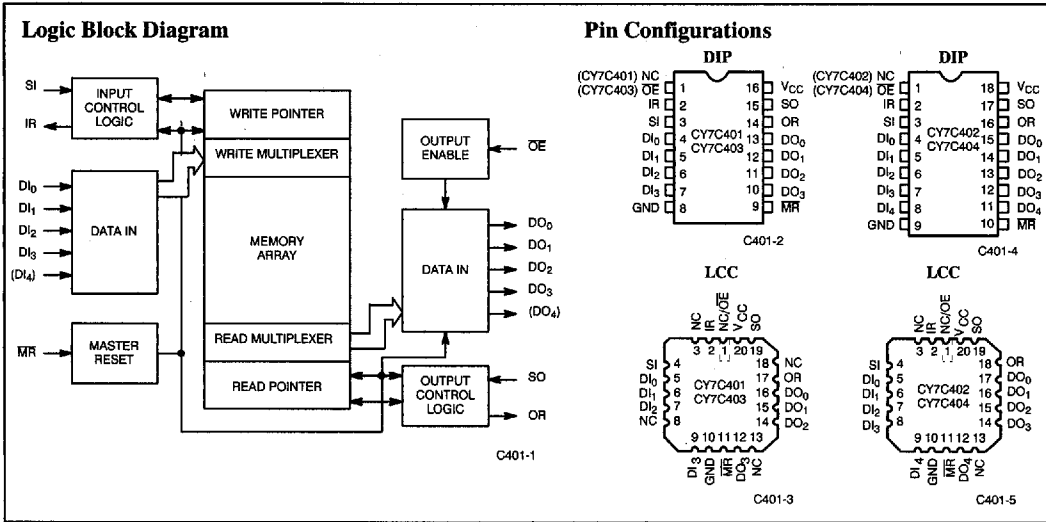

### Selection Guide

	7C401/2-5	7C40X-10	7C40X-15	7C40X-25
Operating Frequency (MHz)	5	10	15	25
Maximum Operating Current (mA)	Commercial	75	75	75
	Military		90	90



**Maximum Ratings**

(Above which the useful life may be impaired. For user guidelines, not tested.)

Storage Temperature .....	-65°C to +150°C
Ambient Temperature with Power Applied .....	-55°C to +125°C
Supply Voltage to Ground Potential .....	-0.5V to +7.0V
DC Voltage Applied to Outputs in High Z State .....	-0.5V to +7.0V
DC Input Voltage .....	-3.0V to +7.0V
Power Dissipation .....	1.0W
Output Current, into Outputs (LOW) .....	20 mA

Static Discharge Voltage .....	>2001V (per MIL-STD-883, Method 3015)
Latch-Up Current .....	>200 mA

**Operating Range**

Range	Ambient Temperature	V <sub>CC</sub>
Commercial	0°C to +70°C	5V ±10%
Military <sup>[1]</sup>	-55°C to +125°C	5V ±10%

**Electrical Characteristics Over the Operating Range (Unless Otherwise Noted)<sup>[2]</sup>**

Parameter	Description	Test Conditions	7C40X-10, 15, 25		Unit
			Min.	Max.	
V <sub>OH</sub>	Output HIGH Voltage	V <sub>CC</sub> = Min., I <sub>OH</sub> = -4.0 mA	2.4		V
V <sub>OL</sub>	Output LOW Voltage	V <sub>CC</sub> = Min., I <sub>OL</sub> = 8.0 mA		0.4	V
V <sub>IH</sub>	Input HIGH Voltage		2.0	6.0	V
V <sub>IL</sub>	Input LOW Voltage		-3.0	0.8	V
I <sub>IX</sub>	Input Leakage Current	GND ≤ V <sub>I</sub> ≤ V <sub>CC</sub>	-10	+10	μA
V <sub>CD</sub> <sup>[3]</sup>	Input Diode Clamp Voltage <sup>[3]</sup>				
I <sub>OZ</sub>	Output Leakage Current	GND ≤ V <sub>OUT</sub> ≤ V <sub>CC</sub> , V <sub>CC</sub> = 5.5V Output Disabled (CY7C403 and CY7C404)	-50	+50	μA
I <sub>OS</sub>	Output Short Circuit Current <sup>[4]</sup>	V <sub>CC</sub> = Max., V <sub>OUT</sub> = GND		-90	mA
I <sub>CC</sub>	Power Supply Current	V <sub>CC</sub> = Max., I <sub>OUT</sub> = 0 mA	Commercial	75	mA
			Military	90	mA

**Capacitance<sup>[5]</sup>**

Parameter	Description	Test Conditions	Max.	Unit
C <sub>IN</sub>	Input Capacitance	T <sub>A</sub> = 25°C, f = 1 MHz, V <sub>CC</sub> = 4.5V	5	pF
C <sub>OUT</sub>	Output Capacitance		7	pF

**AC Test Loads and Waveforms**

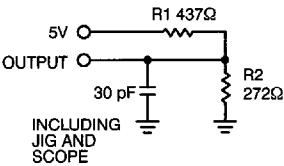

(a) Normal Load

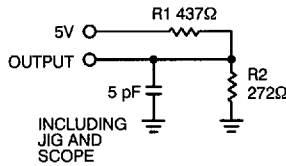

(b) High-Z Load

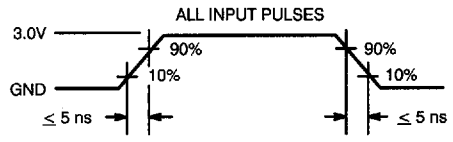

C401-7

Equivalent to: THÉVENIN EQUIVALENT

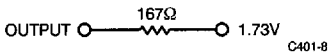

C401-8

**Notes:**

1. T<sub>A</sub> is the "instant on" case temperature.
2. See the last page of this specification for Group A subgroup testing information.
3. The CMOS process does not provide a clamp diode. However, the FIFO is insensitive to -3V dc input levels and -5V undershoot pulses of less than 10 ns (measured at 50% output).
4. For test purposes, not more than one output at a time should be shorted. Short circuit test duration should not exceed 30 seconds.
5. Tested initially and after any design or process changes that may affect these parameters.

**Switching Characteristics Over the Operating Range<sup>[2, 6]</sup>**

Parameter	Description	Test Conditions	7C401-5 7C402-5		7C40X-10		7C40X-15		7C40X-25 <sup>[7]</sup>		Unit
			Min.	Max.	Min.	Max.	Min.	Max.	Min.	Max.	
f <sub>O</sub>	Operating Frequency	Note 8		5		10		15		25	MHz
t <sub>PHSI</sub>	SI HIGH Time		20		20		20		11		ns
t <sub>PLSI</sub>	SO LOW Time		45		30		25		20		ns
t <sub>SSI</sub>	Data Set-Up to SI	Note 9	0		0		0		0		ns
t <sub>HSI</sub>	Data Hold from SI	Note 9	60		40		30		20		ns
t <sub>DLR</sub>	Delay, SI HIGH to IR LOW			75		40		35		21/22	ns
t <sub>DHIR</sub>	Delay, SI LOW to IR HIGH			75		45		40		28/30	ns
t <sub>PHSO</sub>	SO HIGH Time		20		20		20		11		ns
t <sub>PLSO</sub>	SO LOW Time		45		25		25		20		ns
t <sub>DLOR</sub>	Delay, SO HIGH to OR LOW			75		40		35		19/21	ns
t <sub>DHOR</sub>	Delay, SO LOW to OR HIGH			80		55		40		34/37	ns
t <sub>SOR</sub>	Data Set-Up to OR HIGH		0		0		0		0		ns
t <sub>HSO</sub>	Data Hold from SO LOW		5		5		5		5		ns
t <sub>BT</sub>	Bubble-Through Time			200	10	95	10	65	10	50/60	ns
t <sub>SIR</sub>	Data Set-Up to IR	Note 10	5		5		5		5		ns
t <sub>HIR</sub>	Data Hold from IR	Note 10	30		30		30		20		ns
t <sub>PIR</sub>	Input Ready Pulse HIGH		20		20		20		15		ns
t <sub>POR</sub>	Output Ready Pulse HIGH		20		20		20		15		ns
t <sub>PMR</sub>	MR Pulse Width		40		30		25		25		ns
t <sub>DSI</sub>	MR HIGH to SI HIGH		40		35		25		10		ns
t <sub>DOR</sub>	MR LOW to OR LOW			85		40		35		35	ns
t <sub>DIR</sub>	MR LOW to IR HIGH			85		40		35		35	ns
t <sub>LZMR</sub>	MR LOW to Output LOW	Note 11		50		40		35		25	ns
t <sub>OOE</sub>	Output Valid from OE LOW			—		35		30		20	ns
t <sub>HZOE</sub>	Output High Z from OE HIGH	Note 12		—		30		25		15	ns

**Notes:**

- Test conditions assume signal transition time of 5 ns or less, timing reference levels of 1.5V and output loading of the specified I<sub>OL</sub>/I<sub>OH</sub> and 30-pF load capacitance, as in part (a) of AC Test Loads and Waveforms.
- Commercial/Military
- 1/f<sub>O</sub> > t<sub>PHSI</sub> + t<sub>DHIR</sub>, 1/f<sub>O</sub> > t<sub>PHSO</sub> + t<sub>DHOR</sub>
- t<sub>SSI</sub> and t<sub>HSI</sub> apply when memory is not full.

- t<sub>SIR</sub> and t<sub>HIR</sub> apply when memory is full, SI is high and minimum bubble-through (t<sub>BT</sub>) conditions exist.
- All data outputs will be at LOW level after reset goes HIGH until data is entered into the FIFO.
- High-Z transitions are referenced to the steady-state V<sub>OH</sub> - 500 mV and V<sub>OL</sub> + 500 mV levels on the output. t<sub>HZOE</sub> is tested with 5-pF load capacitance as in part (b) of AC Test Loads and Waveforms.

## Operational Description

### Concept

Unlike traditional FIFOs, these devices are designed using a dual-port memory, read and write pointer, and control logic. The read and write pointers are incremented by the SO and SI respectively. The availability of an empty space to shift in data is indicated by the IR signal, while the presence of data at the output is indicated by the OR signal. The conventional concept of bubble-through is absent. Instead, the delay for input data to appear at the output is the time required to move a pointer and propagate an OR signal. The output enable ( $\overline{OE}$ ) signal provides the capability to OR tie multiple FIFOs together on a common bus.

### Resetting the FIFO

Upon power-up, the FIFO must be reset with a master reset (MR) signal. This causes the FIFO to enter an empty condition signified by the OR signal being LOW at the same time the IR signal is HIGH. In this condition, the data outputs ( $DO_0 - DO_n$ ) will be in a LOW state.

### Shifting Data In

Data is shifted in on the rising edge of the SI signal. This loads input data into the first word location of the FIFO. On the falling edge of the SI signal, the write pointer is moved to the next word position and the IR signal goes HIGH, indicating the readiness to accept new data. If the FIFO is full, the IR will remain LOW until a word of data is shifted out.

### Shifting Data Out

Data is shifted out of the FIFO on the falling edge of the SO signal. This causes the internal read pointer to be advanced to the next word location. If data is present, valid data will appear on the outputs and the OR signal will go HIGH. If data is not present, the OR signal will stay LOW indicating the FIFO is empty. Upon the rising edge of SO, the OR signal goes LOW. The data outputs of the FIFO should be sampled with edge-sensitive type D flip-flops (or equivalent), using the SO signal as the clock input to the flip-flop.

### Bubble-Through

Two bubble-through conditions exist. The first is when the device is empty. After a word is shifted into an empty device, the data propagates to the output. After a delay, the OR flag goes HIGH, indicating valid data at the output.

The second bubble-through condition occurs when the device is full. Shifting data out creates an empty location that propagates to the input. After a delay, the IR flag goes HIGH. If the SI signal is HIGH at this time, data on the input will be shifted in.

### Possible Minimum Pulse Width Violation at the Boundary Conditions

If the handshaking signals IR and OR are not properly used to generate the SI and SO signals, it is possible to violate the minimum (effective) SI and SO positive pulse widths at the full and empty boundaries.

When this violation occurs, the operation of the FIFO is unpredictable. It must then be reset, and all data is lost.

### Application of the 7C403-25/7C404-25 at 25 MHz

Application of the CY7C403 or CY7C404 Cypress CMOS FIFOs requires knowledge of characteristics that are not easily specified in a datasheet, but which are necessary for reliable operation under all conditions, so we will specify them here.

When an empty FIFO is filled with initial information at maximum "shift in" SI frequency, followed by immediate shifting out of the data also at maximum "shift out" SO frequency, the designer must

be aware of a window of time which follows the initial rising edge of the OR signal, during which time the SO signal is not recognized. This condition exists only at high-speed operation where more than one SO may be generated inside the prohibited window. This condition does not inhibit the operation of the FIFO at full-frequency operation, but rather delays the full 25-MHz operation until after the window has passed.

There are several implementation techniques for managing the window so that all SO signals are recognized:

1. The first involves delaying SO operation such that it does not occur in the critical window. This can be accomplished by causing a fixed delay of 40 ns "initiated by the SI signal only when the FIFO is empty" to inhibit or gate the SO activity. However, this requires that the SO operation be at least temporarily synchronized with the input SI operation. In synchronous applications this may well be possible and a valid solution.
2. Another solution not uncommon in synchronous applications is to only begin shifting data out of the FIFO when it is more than half full. This is a common method of FIFO application, as earlier FIFOs could not be operated at maximum frequency when near full or empty. Although Cypress FIFOs do not have this limitation, any system designed in this manner will not encounter the window condition described above.
3. The window may also be managed by not allowing the first SO signal to occur until the window in question has passed. This can be accomplished by delaying the SO 40 ns from the rising edge of the initial OR signal. This however involves the requirement that this only occurs on the first occurrence of data being loaded into the FIFO from an empty condition and therefore requires the knowledge of IR and SI conditions as well as SO.
4. Handshaking with the OR signal is a third method of avoiding the window in question. With this technique the rising edge of SO, or the fact that SO signal is HIGH, will cause the OR signal to go LOW. The SO signal is not taken LOW again, advancing the internal pointer to the next data, until the OR signal goes LOW. This ensures that the SO pulse that is initiated in the window will be automatically extended long enough to be recognized.
5. There remains the decision as to what signal will be used to latch the data from the output of the FIFO into the receiving source. The leading edge of the SO signal is most appropriate because data is guaranteed to be stable prior to and after the SO leading edge for each FIFO. This is a solution for any number of FIFOs in parallel.

Any of the above solutions will ensure the correct operation of a Cypress FIFO at 25 MHz. The specific implementation is left to the designer and is dependent on the specific application needs.

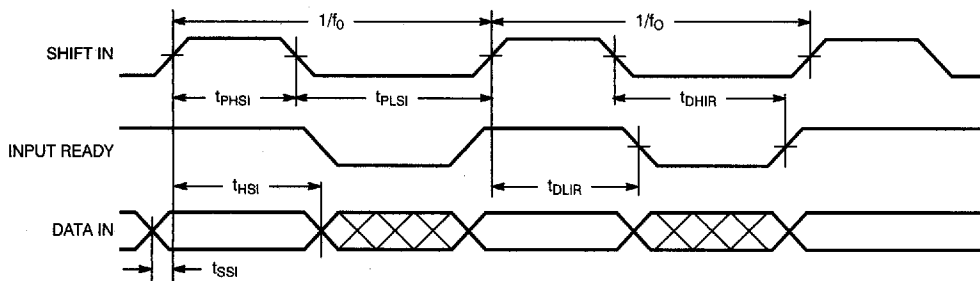
**Switching Waveforms**
**Data In Timing Diagram**

C401-9

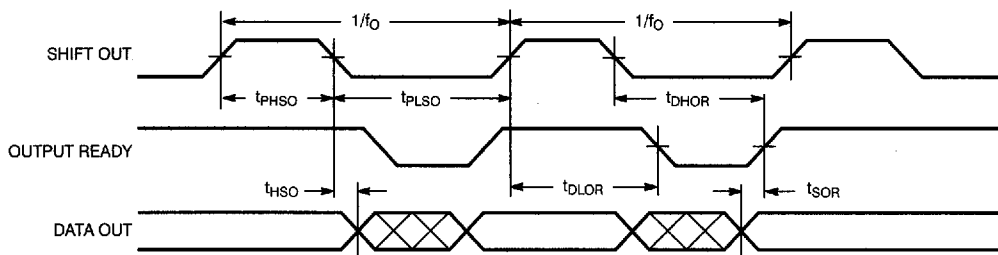
**Data Out Timing Diagram**

C401-10

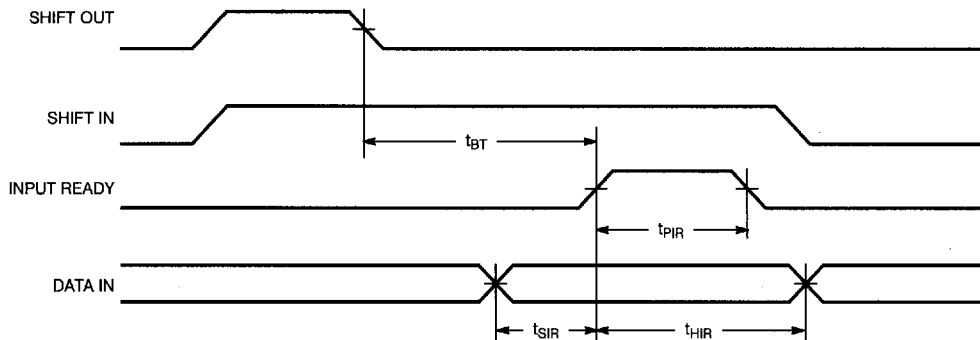
**Bubble Through, Data Out To Data In Diagram**

C401-11

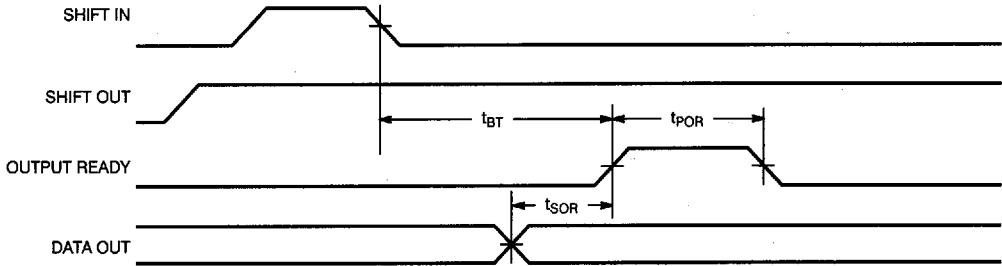
**Switching Waveforms (continued)**
**Bubble Through, Data In To Data Out Diagram**

C401-12

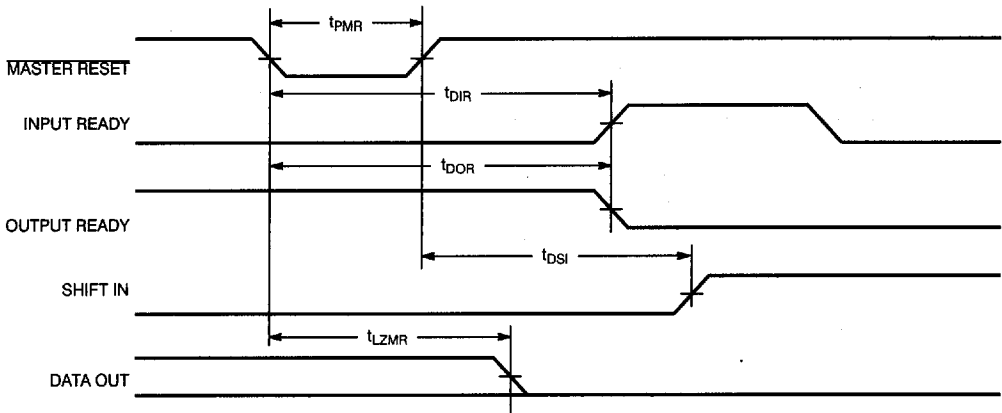
**Master Reset Timing Diagram**

C401-13

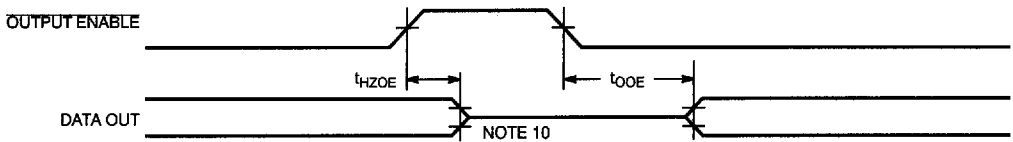
**Output Enable Timing Diagram**

C401-14

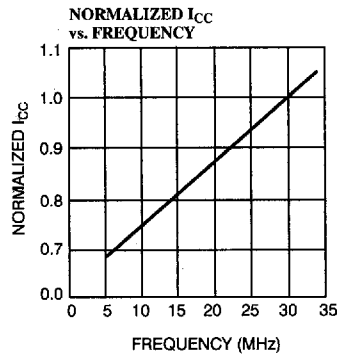
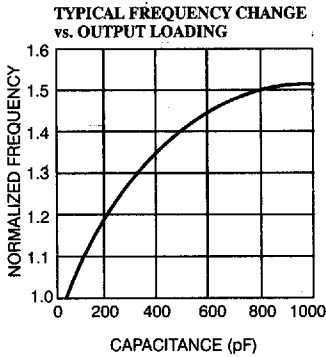
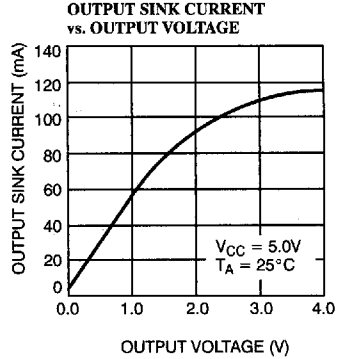
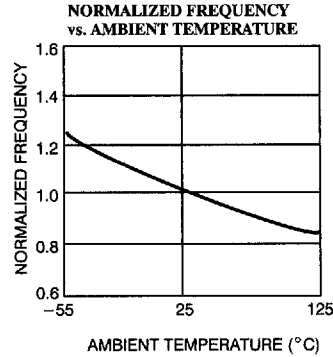
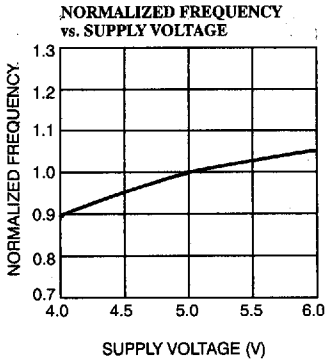
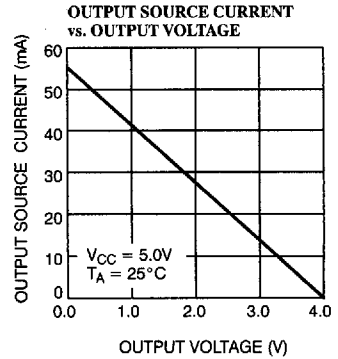
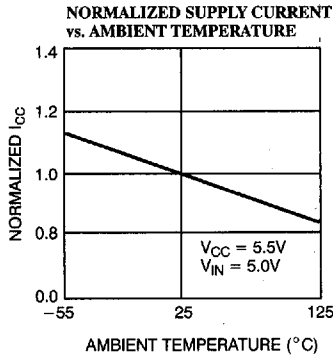
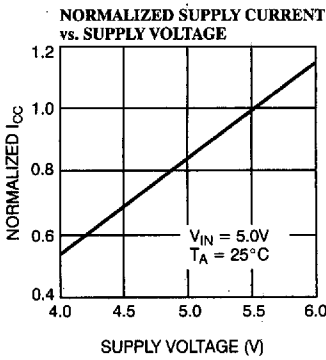
**Typical DC and AC Characteristics**

C401-15





**Ordering Information**

Speed	Ordering Code	Package Name	Package Type	Operating Range
5	CY7C401-5PC	P1	16-Lead (300-Mil) Molded DIP	Commercial
10	CY7C401-10DC	D2	16-Lead (300-Mil) CerDIP	Commercial
	CY7C401-10PC	P1	16-Lead (300-Mil) Molded DIP	
	CY7C401-10DMB	D2	16-Lead (300-Mil) CerDIP	Military
	CY7C401-10LMB	L61	20-Pin Square Leadless Chip Carrier	
15	CY7C401-15DC	D2	16-Lead (300-Mil) CerDIP	Commercial
	CY7C401-15PC	P1	16-Lead (300-Mil) Molded DIP	
	CY7C401-15DMB	D2	16-Lead (300-Mil) CerDIP	Military
	CY7C401-15LMB	L61	20-Pin Square Leadless Chip Carrier	
25	CY7C401-25DC	D2	16-Lead (300-Mil) CerDIP	Commercial
	CY7C401-25PC	P1	16-Lead (300-Mil) Molded DIP	
	CY7C401-25DMB	D2	16-Lead (300-Mil) CerDIP	Military
	CY7C401-25LMB	L61	20-Pin Square Leadless Chip Carrier	

Speed (MHz)	Ordering Code	Package Name	Package Type	Operating Range
5	CY7C402-5PC	P3	18-Lead (300-Mil) Molded DIP	Commercial
10	CY7C402-10DC	D4	18-Lead (300-Mil) CerDIP	Commercial
	CY7C402-10PC	P3	20-Pin Square Leadless Chip Carrier	
	CY7C402-10DMB	D4	18-Lead (300-Mil) CerDIP	Military
	CY7C402-10LMB	L61	20-Pin Square Leadless Chip Carrier	
15	CY7C402-15DC	D4	18-Lead (300-Mil) CerDIP	Commercial
	CY7C402-15PC	P3	18-Lead (300-Mil) Molded DIP	
	CY7C402-15DMB	D4	18-Lead (300-Mil) CerDIP	Military
	CY7C402-15LMB	L61	20-Pin Square Leadless Chip Carrier	
25	CY7C402-25DC	D4	18-Lead (300-Mil) CerDIP	Commercial
	CY7C402-25PC	P3	18-Lead (300-Mil) Molded DIP	
	CY7C402-25DMB	D4	18-Lead (300-Mil) CerDIP	Military
	CY7C402-25LMB	L61	20-Pin Square Leadless Chip Carrier	



**Ordering Information** (continued)

Speed (MHz)	Ordering Code	Package Name	Package Type	Operating Range
10	CY7C403-10DC	D2	16-Lead (300-Mil) CerDIP	Commercial
	CY7C403-10PC	P1	16-Lead (300-Mil) Molded DIP	
	CY7C403-10DMB	D2	16-Lead (300-Mil) CerDIP	Military
	CY7C403-10LMB	L61	20-Pin Square Leadless Chip Carrier	
15	CY7C403-15DC	D2	16-Lead (300-Mil) CerDIP	Commercial
	CY7C403-15PC	P1	16-Lead (300-Mil) Molded DIP	
	CY7C403-15DMB	D2	16-Lead (300-Mil) CerDIP	Military
	CY7C403-15LMB	L61	20-Pin Square Leadless Chip Carrier	
25	CY7C403-25DC	D2	16-Lead (300-Mil) CerDIP	Commercial
	CY7C403-25PC	P1	16-Lead (300-Mil) Molded DIP	
	CY7C403-25DMB	D2	16-Lead (300-Mil) CerDIP	Military
	CY7C403-25LMB	L61	20-Pin Square Leadless Chip Carrier	

Speed (MHz)	Ordering Code	Package Name	Package Type	Operating Range
10	CY7C404-10DC	D4	18-Lead (300-Mil) CerDIP	Commercial
	CY7C404-10PC	P3	18-Lead (300-Mil) Molded DIP	
	CY7C404-10DMB	D4	18-Lead (300-Mil) CerDIP	Military
	CY7C404-10LMB	L61	20-Pin Square Leadless Chip Carrier	
15	CY7C404-15DC	D4	18-Lead (300-Mil) CerDIP	Commercial
	CY7C404-15PC	P3	18-Lead (300-Mil) Molded DIP	
	CY7C404-15DMB	D4	18-Lead (300-Mil) CerDIP	Military
	CY7C404-15LMB	L61	20-Pin Square Leadless Chip Carrier	
25	CY7C404-25DC	D4	18-Lead (300-Mil) CerDIP	Commercial
	CY7C404-25PC	P3	18-Lead (300-Mil) Molded DIP	
	CY7C404-25DMB	D4	18-Lead (300-Mil) CerDIP	Military
	CY7C404-25LMB	L61	20-Pin Square Leadless Chip Carrier	



**MILITARY SPECIFICATIONS**  
**Group A Subgroup Testing**

**DC Characteristics**

Parameters	Subgroups
V <sub>OH</sub>	1, 2, 3
V <sub>OL</sub>	1, 2, 3
V <sub>IH</sub>	1, 2, 3
V <sub>IL Max.</sub>	1, 2, 3
I <sub>IX</sub>	1, 2, 3
I <sub>OZ</sub>	1, 2, 3
I <sub>OS</sub>	1, 2, 3
I <sub>CC</sub>	1, 2, 3

**Switching Characteristics**

Parameters	Subgroups
f <sub>O</sub>	7, 8, 9, 10, 11
t <sub>PHSI</sub>	7, 8, 9, 10, 11
t <sub>PLSI</sub>	7, 8, 9, 10, 11
t <sub>SSI</sub>	7, 8, 9, 10, 11
t <sub>HSI</sub>	7, 8, 9, 10, 11
t <sub>DLIR</sub>	7, 8, 9, 10, 11
t <sub>DHIR</sub>	7, 8, 9, 10, 11
t <sub>PHSO</sub>	7, 8, 9, 10, 11
t <sub>PLSO</sub>	7, 8, 9, 10, 11
t <sub>DLOR</sub>	7, 8, 9, 10, 11
t <sub>DHOR</sub>	7, 8, 9, 10, 11
t <sub>SOR</sub>	7, 8, 9, 10, 11
t <sub>HSO</sub>	7, 8, 9, 10, 11
t <sub>BT</sub>	7, 8, 9, 10, 11
t <sub>SIR</sub>	7, 8, 9, 10, 11
t <sub>HIR</sub>	7, 8, 9, 10, 11
t <sub>PIR</sub>	7, 8, 9, 10, 11
t <sub>POR</sub>	7, 8, 9, 10, 11
t <sub>PMR</sub>	7, 8, 9, 10, 11
t <sub>DSI</sub>	7, 8, 9, 10, 11
t <sub>DOR</sub>	7, 8, 9, 10, 11
t <sub>DIR</sub>	7, 8, 9, 10, 11
t <sub>LZMR</sub>	7, 8, 9, 10, 11
t <sub>OOE</sub>	7, 8, 9, 10, 11
t <sub>HZOE</sub>	7, 8, 9, 10, 11

Document #: 38-00040-H