

Model(型號): **ROTARY POTENTIOMETER-----R08M1MH0[x]**

► Download PDF file

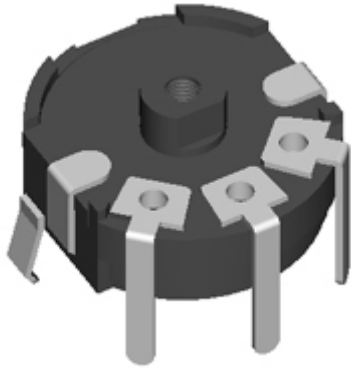

Features:(特點):

Small size,high dependability
thanks to its structure eliminating openings.
Excellent operational feeling

Applications(作用):

Suitable for various control applications
with general consumer electronics products,
automotive installation equipment and devices,
industrial machines ,etc

Dimensions(規格圖):

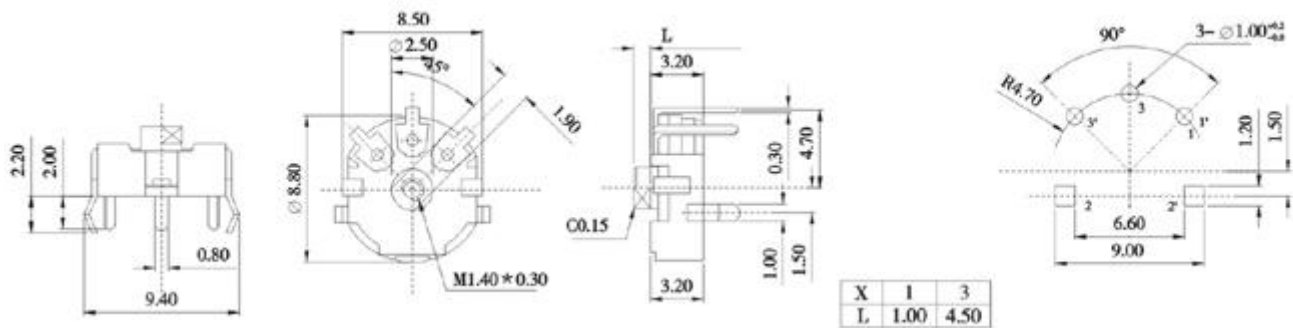

Specifications(規格)

Electrical Characteristics [電氣性能]

Total resistance [全阻抗值]	5KΩ - 1MΩ
Total resistance tolerance [全阻抗值容許差]	±30%
Ratings power(w) [額定功率]	0.03W
Resistance taper [阻抗變化特性]	A,B,C,,D
Sliding noise [滑動雜音]	100mV Max.
Gang error [連動誤差]	-40dB~0dB ±3dB Max.
Max. operating voltage [最高使用電壓]	AC 50V

Mechanical Characteristics [機械性能]

Operation torque [回轉力矩]	10~100gf . cm
Rotation stopper strength [止動強度]	1Kgf . cm Min.
Total rotational angle [回轉角度]	200 ±10°

Endurance Characteristics [耐久性能]

Rotational life [回轉壽命]	More than10,000 cycles
--------------------------	------------------------