

# **F1E21**

# **Databook**

Confidential / Preliminary Documentation

Revision 1.0

Copyright© 2006 F1BT Corp.

# List of Contents

- 1 General
  - 1.1 Overview
  - 1.2 Features
  - 1.3 Application
  - 1.4 Pinout Diagram & Outline Size
  - 1.5 Device Terminal Descriptions
  - 1.6 Package Dimensions
  
- 2 Characteristics
  - 2.1 Electrical Characteristics
  - 2.2 Radio Characteristics
  
- 3 Terminal Description
  - 3.1 UART
    - 3.1.1 UART Setting
    - 3.1.2 UART Bypass Mode
  - 3.2 USB
  - 3.3 I<sup>2</sup>C
  - 3.4 Audio PCM interface
    - 3.4.1 PCM Configuration
  
- 4 Boot Interface configures
  
- 5 Application Schematic
  
- 6 Revision History

# 1. General

## 1.1 overview

This specification covers Bluetooth module (class-2) which complies with Bluetooth specification version 2.0 + EDR and integrates RF & Baseband controller in small package. This Module has deployed CSR's BC04-External chipset.

All detailed specification including pinouts and electrical specification may be changed without notice.

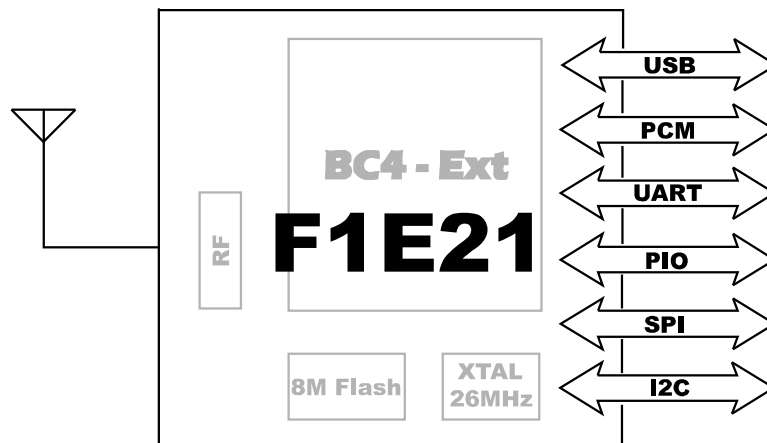

## Overview F1E21

## 1.2 Features

- Fully Qualified Bluetooth v2.0 + EDR
- Enhanced Data Rate (EDR) compliant with v2.0.E.2 of specification for both 2Mbps and 3Mbps modulation modes
- Full-speed Bluetooth Operation with Full Piconet Support
- Scatternet Support
- Low Power Consumption
- Support for 802.11 Co-existence
- RoHS Compliant
- USB and Dual UART Ports
- Competitive Size (11mm x 11mm x 1.56mm : QFN 36Pin)

## 1.3 Application

- Notebook PC, Desktop PC
- PDA
- Cordless headset
- Digital camera & printer
- GPS,POS, Barcode Reader
- Domestic and industrial applications
- Access Point
- Serial Adapter

## 1.4 Pinout Diagram & Outline Size

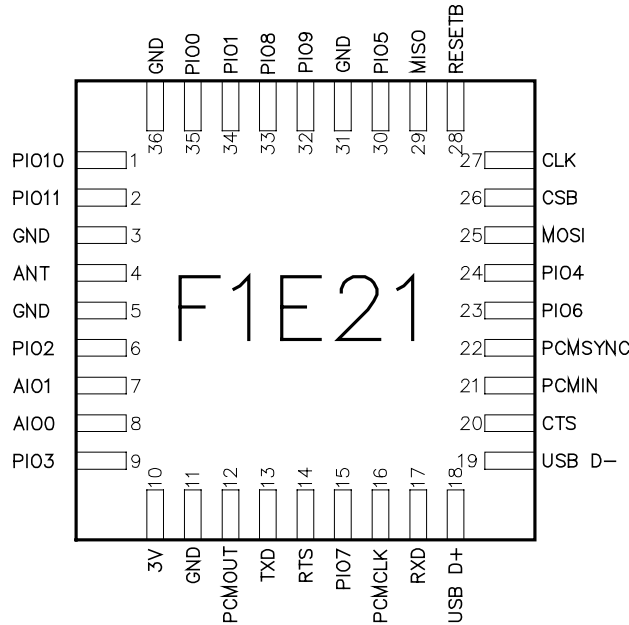

**F1E21 Pinout Diagram**

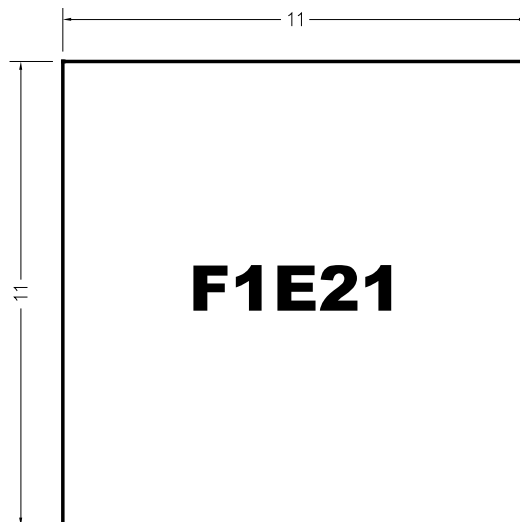

**F1E21 Size**

## 1.5 Device Terminal Functions

	<b>PIN</b>	<b>Name</b>	<b>Description</b>
PCM	PCM OUT	12	Synchronous data output
	PCM IN	21	Synchronous data input
	PCM CLK	16	Synchronous data clock
	PCM SYNC	22	Synchronous data sync
UART	TXD	13	UART data output, active low
	RXD	17	UART data input, active low (idle status high)
	CTS	20	
	RTS	14	
USB	USB -	19	USB -
	USB +	18	USB + with selectable internal 1.5k pull-up resistor
PIO & AIO	PIO0	35	Programmable input/output line  PIO 4,5,6,7 Can be used UART bypass mode  PIO 6,7,8 Can be used to form I2C interface
	PIO1	34	
	PIO2	6	
	PIO3	9	
	PIO4	24	
	PIO5	30	
	PIO6	23	
	PIO7	15	
	PIO8	33	
	PIO9	32	
	PIO10	1	
	PIO11	2	
	AIO0	8	
	AIO1	7	
SPI	SPI MOSI	25	Serial Peripheral Interface data input
	SPI CLK	27	Serial Peripheral Interface clock
	SPI MISO	29	Serial Peripheral Interface data output
	SPI CSB	26	Chip Select for Synchronous SPI active low
Other Pins	ANT	4	RF Connection to Antenna
	GND	3,5,11,31,36	Ground
	3V	10	Main supply input voltage.
	RESETB	28	Reset if low. Input debounced so must be low for >5ms to cause a reset

## 1.6 Module Dimension

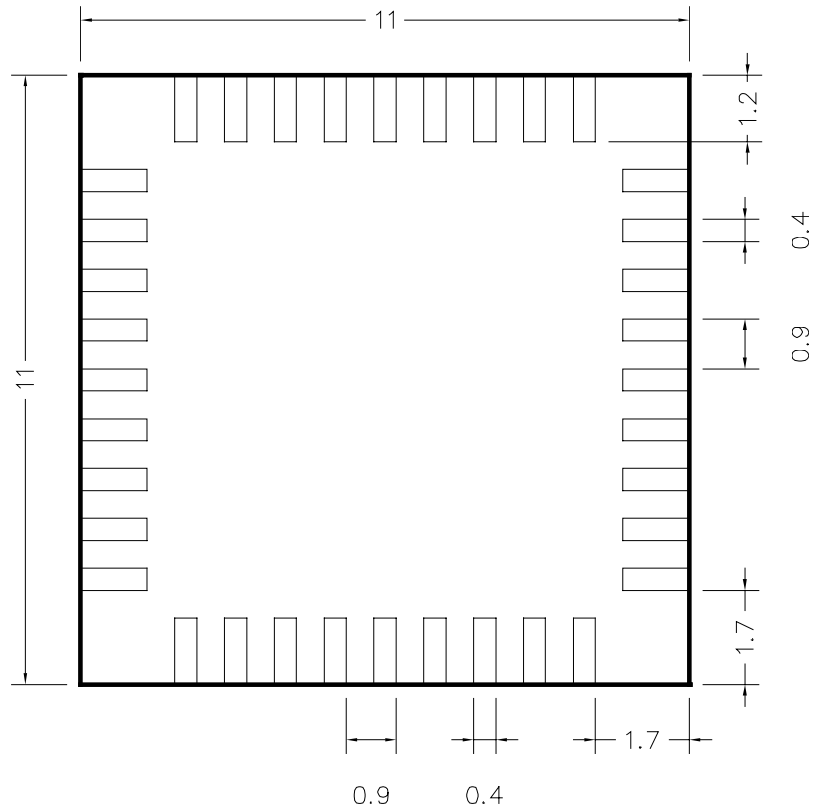

## 2. Characteristics

### 2.1 Electrical Characteristics

Absolute Maximum Ratings		
Rating	Minimum	Maximum
Storage temperature	-40°C	85°C
Supply voltage : VCC	-0.4V	3.7V
Other terminal voltages	VSS-0.4V	VCC+0.4V

Recommended Operating Conditions		
Operating Condition	Minimum	Maximum
Operating temperature range	-30°C	70°C
Supply voltage : VCC	1.7V	3.6V



## 2.2 RF Characteristics

### Transmitter

Specification	Condition	Min	Typ	Max	Unit
Output transmit power	Normal	-6	1	4	dBm
Transmit power density	Normal			4	dBm
Transmit power control	Normal	2		8	dBm
Frequency Range	Normal	2400		2483.5	MHz
20dB bandwidth for modulated carrier	Normal		850	1000	KHz
Adjacent channel transmit power	±2MHz ±3MHz ±4MHz			-20 -40 -40	dBm
Modulation Characteristics	f1avg f2max f2avg / f1avg	140 115		175 80	KHz KHz %
Initial carrier frequency tolerance	Normal	-20		20	KHz
Carrier frequency Drift	One slot packet(DH1) Three slot packet(DH3) Five slot packet(DH5)	-25 -40 -40		25 40 40	KHz

### Transceiver

Specification	Condition	Min	Typ	Max	Unit
Adjacent channel transmit power	30MHz ~ 1GHz 1GHz ~12.75GHz 1.8GHz ~5.1GHz 5.1GHz ~5.3GHz			-36 -30 -47 -47	dBm

### Receiver

Specification	Condition	Min	Typ	Max	Unit
Sensitivity level (0.1% BER)	Single slot packets	-70	-80		dBm
Transmit power density	Multi slot packet	-70	-80		dBm
C/I performance	co-channel 1MHz (Adjacent channel) 2MHz (2nd Adjacent channel) 3MHz (3rd Adjacent channel)			11 0 -30 -40	dB
Blocking performance	30MHz ~ 2000MHz 2000MHz ~ 2400MHz 2500MHz ~ 3000MHz 3000MHz ~ 12.75GHz	-10 -27 -27 -10			dBm
Intermodulation performance	n=5	-39			dBm
Maximum input level		-20	-10		dBm

## 3. Terminal Description

### 3.1 UART

Four signals are used to implement the UART function.

UART\_TXD and UART\_RXD transfer data between the two devices.

#### 3.1.1 UART Setting

User can change data format the following selection using PSKEY.

However, host shall communicate with default setting UART connection initiated at first time.

$$\text{Baud Rate} = (\text{PSKEY\_UART\_BAUD\_RATE}) / 0.004096$$

Parameter	Possible value
Baud Rate	9600 ~ 3M Baud
Flow Control	None
Parity	None, Odd or Even
Number of Stop Bits	1 or 2
Bits per channel	8

#### 3.1.2 UART Bypass Mode

In order to apply the UART bypass mode, a BCCMD command will be issued to F1E21 upon this , it will switch the bypass to PIO4,5,6,7 as shown in figure. When the bypass mode has been invoked, module enters the deep sleep state indefinitely

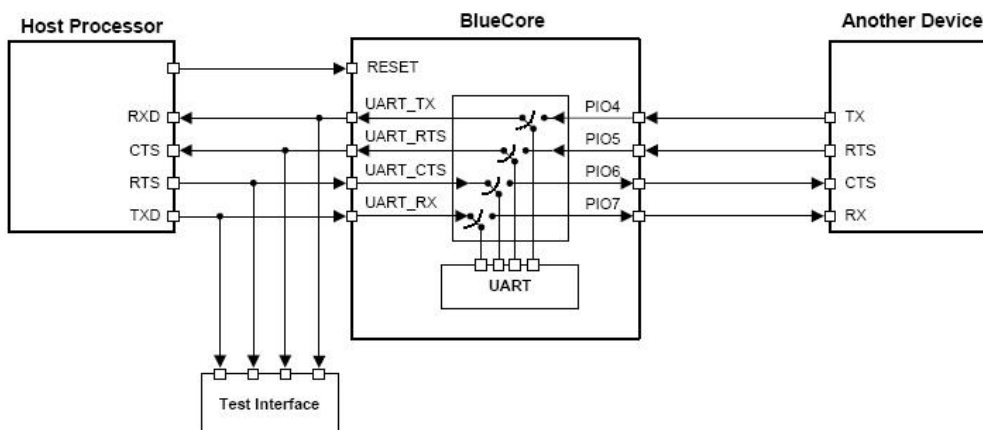

## 3.2 USB

BlueCore4 - External devices contain a full speed (12Mbits/s) USB interface that is capable of driving a USB cable directly. No external USB transceiver is required. The device operates as a USB peripheral, responding to requests from a master host controller such as a PC. Both the OHCI and the UHCI standards are supported. The set of USB endpoints implemented can behave as specified in the USB section of the Bluetooth specification v1.2 or alternatively can appear as a set of endpoints appropriate to USB audio devices such as speakers.

As USB is a Master/slave oriented system (in common with other USB peripherals), BlueCore3-Multimedia External only supports USB slave operation.

## 3.3 I<sup>2</sup>C

PIO[8:6] can be used to form an interface. The interface is driven by “bit banging” these PIO pins using software. Therefore it is suited only to relatively slow functions such as driving a dot matrix liquid crystal display (LCD).

Note. PIO[7:6] dual functions, UART bypass and EEPROM support, therefore devices using an EEPROM connect support UART bypass mode. PIO Lines need to be pulled-up through 2.2K

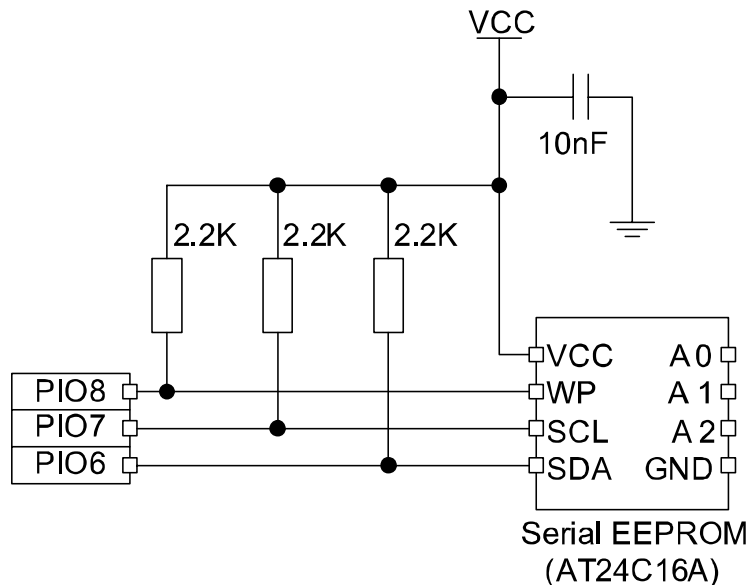

## 3.4 PCM

Pulse Code Modulation (PCM) is a standard method used to digitize audio (particularly voice) patterns for transmission over digital communication channels. Through its PCM interface, this module has hardware support for continual transmission and reception of PCM data, so reducing processor overhead for wireless headset applications. This module offers a bi-directional digital audio interface that route directly into the baseband lauer of the on-chip firmware. It dose not pass through the HCI protocol layer.

Hardware allows the data to be sent to and received from a SCO connection. This module interfaces directly to PCM audio devices including the following:

- Qualcomm MSM 3000 series and MSM 5000 series CDMA baseband devices
- OKI MSM7705 for channel A-law and u-law CODEC
- Motorola MC145481 8-bit A-law and u-law CODEC
- Motorola MC145483 13-bit linear CODEC
- STW 5093 and 5094 14-bit linear CODECs

### 3.4.1 PCM Configuration

The PCM configuration is set using two PS keys, PSKEY\_PCM\_CONFIG32 and PSKEY\_PCM\_LOW\_JITTER\_CONFIG. The default for long frame sync and interface master generating 256KHz PCM\_CLK with no tri-state of PCM\_OUT.

Parameter	Possible value
Mode	Slave, Master
Clock rate	Master Mode : 128, 256, 512KHz Slave Mode : up to 2048KHz
Sync formats	Long frame sync, Short frame sync
Data formats	13 or 16bit linear, 8-bit A-law to u-law

## 4. Revision History

Revision	Date	Change Descriptions	Issued by
Rev 1.0	2006-12-21	Initial release	Narsen

## 5. Application Schematic

### \*Microstrip Line Recommend

4Layer 0.8T PCB : Trance width = 0.34mm (1~2Layer Copper thickness = 0.2mm)  
 2Layer 0.8T PCB : Trance width = 1.45mm

