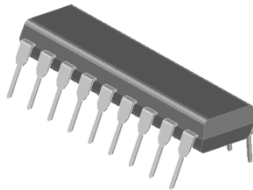

SOP-20

DIP-18

ORDERING INFORMATION

Product	Marking	Package
S3770x	S3770x	SOP-20
S3770xP	S3770x	DIP-18

▲ Marking Detail Information

S3770x....[1]
YWW....[2]

[1] Device Code [x: Item Code]

[2] Year & Week Code

Description

The S3770x Series are high-voltage, high-current Darlington transistor arrays. Each consists of eight NPN Darlington pairs that feature high-voltage outputs with common-cathode clamp diodes for switching inductive loads. The collector-current rating of a single Darlington pair is 500mA. The Darlington pairs can be paralleled for higher current capability. Applications include relay drivers, hammer drivers, lamp drivers, display drivers (LED and gas discharge), line drivers, and logic buffers.

Application

- ◆ Relay Controller
- ◆ Lamp and Display LED Driver
- ◆ Motor Driver

Features and Benefits

- ◆ Output Current (single output) 500mA(Max.)
- ◆ High sustaining voltage output
- ◆ Output clamp diode
- ◆ Inputs compatible with various types of logic
- ◆ Package : SOP-20, DIP-18

Block Diagram & Pin Configuration

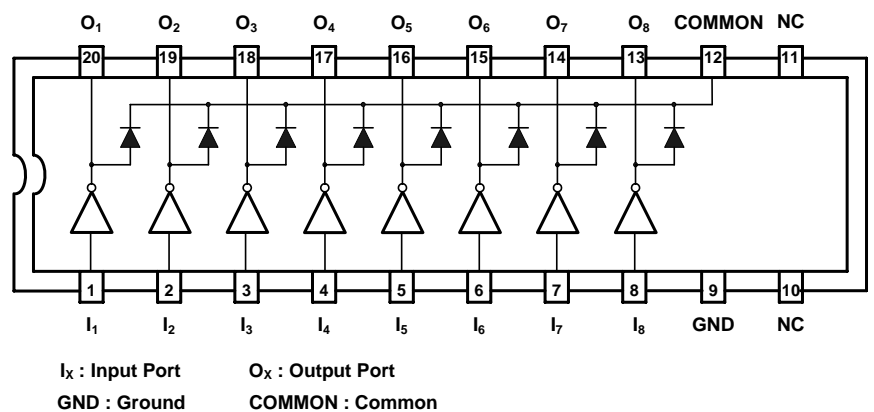

◆ Schematics (Each Driver)

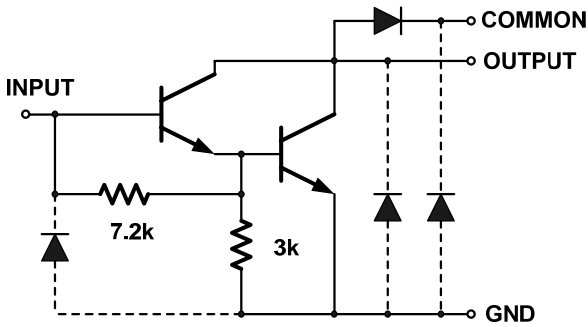

S37701

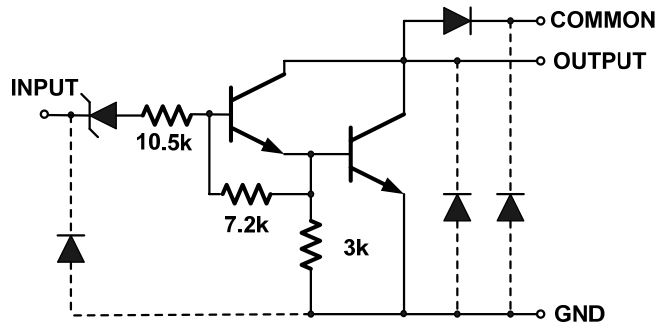

S37702

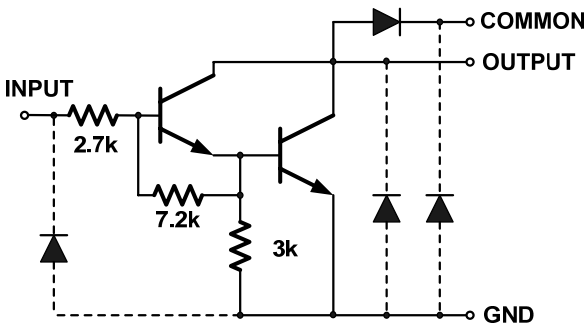

S37703

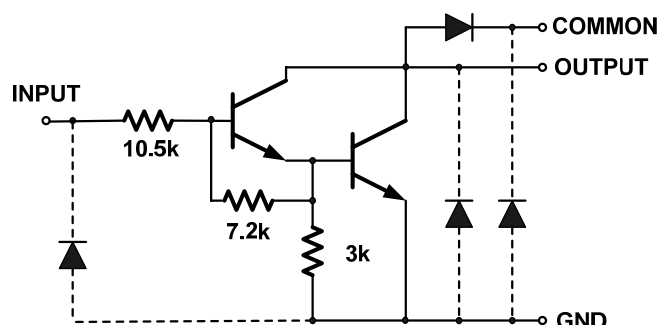

S37704

◆ Product Line-up

Product Name	Input Bias Resistor	Designation	Operating Temperature	Package
S37701/P	External	General Purpose	-40~85°C	SOP-20 / DIP-18
S37702/P	10.5KΩ + 7V Zener Diode	14~25V P-MOS	-40~85°C	SOP-20 / DIP-18
S37703/P	2.7KΩ	TTL, 5V C-MOS	-40~85°C	SOP-20 / DIP-18
S37704/P	10.5KΩ	6~15 P-MOS, C-MOS	-40~85°C	SOP-20 / DIP-18

◆ **Absolute Maximum Ratings** ($T_a = 25^\circ\text{C}$)

Parameter	Symbol	Rating		Unit
		SOP-20	DIP-18	
Output Sustaining Voltage	$V_{CE(SUS)}$	-0.5~50		V
Output Current	I_{OUT}	500		mA / ch
Input Voltage	V_{IN} (Note 1)	-0.5~30		V
Input Current	I_{IN} (Note 2)	25		mA
Clamp Diode	Reverse Voltage	V_R	50	V
	Forward Current	I_F	500	mA
Power Dissipation	P_d	0.96	1.47	W
Junction Temperature	T_J	150		$^\circ\text{C}$
Operate Temperature Range	T_{opr}	-40 ~ +85		$^\circ\text{C}$
Storage Temperature Range	T_{stg}	-55 ~ +150		$^\circ\text{C}$

Note 1) Except S37701/P, Note 2) Only S37701/P

◆ **Recommended Operating Conditions** ($T_a = -40 \sim 85^\circ\text{C}$)

Characteristic	Symbol	Test Condition	Min.	Typ.	Max.	Unit	
Output Sustaining Voltage	$V_{CE(SUS)}$	-	0	-	50	V	
Output Current	I_{OUT}	DIP-18	TPW=25ms, DF=8%, 8 Circuits	0	-	400	
		SOP-20					TPW=25ms, DF=25%, 8 Circuits
			SOP-20	TPW=25ms, DF=8%, 8 Circuits	0	-	
		SOP-20					TPW=25ms, DF=25%, 8 Circuits
Input Voltage	V_{IN}		Except S37701/P	0	-	30	
Input Voltage (Output ON)	$V_{IN(ON)}$	S37702/P	14	-	30	V	
		S37703/P	3.5	-	30		
		S37704/P	8	-	30		
Input Current	I_{IN}	Only S37701/P	0	-	5	mA	
Clamp Diode Reverse Voltage	V_R	-	-	-	50	V	
Clamp Diode Forward Current	I_F	-	-	-	400	mA	
Power Dissipation	DIP-18	P_D	$T_a = 85^\circ\text{C}$	-	-	0.52	W
	SOP-20		$T_a = 85^\circ\text{C}$	-	-	0.38	

◆ **Electrical characteristics** (Ta=-40~85°C; unless otherwise specified)

Characteristic		Symbol	Test Circuit	Test Condition	Min.	Typ.	Max.	Unit
Output Leakage Current		I _{CEX}	1	V _{CE} =50V, Ta=25°C	-	-	50	uA
				V _{CE} =50V, Ta=85°C	-	-	100	
	S37702/P			V _{CE} =50V, V _{IN} =6V	-	-	500	
	S37704/P			V _{CE} =50V, V _{IN} =1V	-	-	500	
Collector – Emitter Saturation Voltage		V _{CE(SAT)}	2	I _{OUT} =350mA, I _{IN} =500uA	-	1.3	1.6	V
				I _{OUT} =200mA, I _{IN} =350uA	-	1.1	1.3	
				I _{OUT} =100mA, I _{IN} =250uA	-	0.9	1.1	
Input Current	S37702/P	I _{IN(ON)}	3	V _{IN} =17V	-	0.82	1.25	mA
	S37703/P			V _{IN} =3.85V	-	0.93	1.35	
	S37704/P			V _{IN} =5V	-	0.35	0.5	
				V _{IN} =12V	-	1.0	1.45	
		I _{IN(OFF)}	4	I _{OUT} =500uA, Ta=85°C	50	65	-	uA
Input Voltage	S37702/P	V _{IN(ON)}	5	V _{CE} =2V, I _{OUT} =300mA	-	-	13	V
	S37703/P			V _{CE} =2V, I _{OUT} =200mA	-	-	2.4	
				V _{CE} =2V, I _{OUT} =250mA	-	-	2.7	
	S37704/P			V _{CE} =2V, I _{OUT} =300mA	-	-	3.0	
				V _{CE} =2V, I _{OUT} =125mA	-	-	5.0	
				V _{CE} =2V, I _{OUT} =200mA	-	-	6.0	
				V _{CE} =2V, I _{OUT} =275mA	-	-	7.0	
				V _{CE} =2V, I _{OUT} =350mA	-	-	8.0	
DC Current Transfer Ratio		h _{FE}	2	V _{CE} =2V, I _{OUT} =350mA	1000	-	-	
Clamp Diode Reverse Current		I _R	6	V _R =50V, Ta=25°C	-	-	50	uA
				V _R =50V, Ta=85°C	-	-	100	
Clamp Diode Forward Voltage		V _F	7	I _F =350mA	-	-	2.0	V
Input Capacitance		C _{IN}		-	-	15	-	pF
Turn-ON Delay		t _{ON}	8	V _{OUT} =50V, R _L =120Ω, C _L =15pF	-	0.1	-	uS
Turn-OFF Delay		t _{OFF}			-	0.2	-	

Test Circuit

1. I_{CEX}

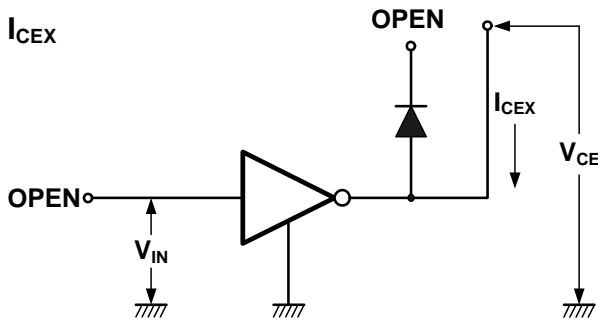

2. $V_{CE(sat)}$, h_{FE}

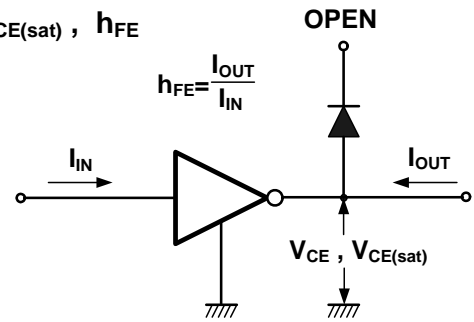

3. $I_{IN(ON)}$

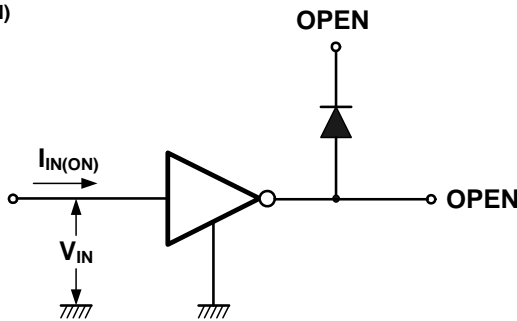

4. $I_{IN(OFF)}$

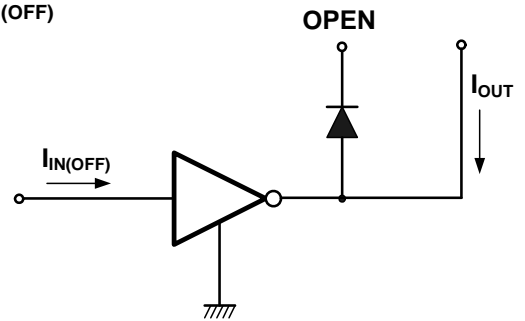

5. $V_{IN(ON)}$

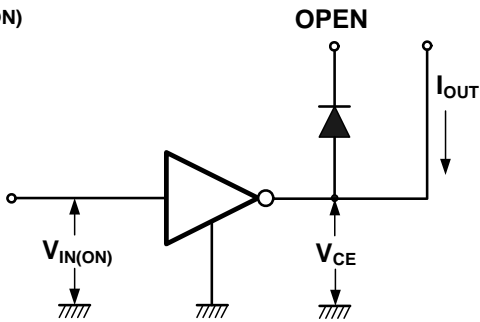

6. I_R

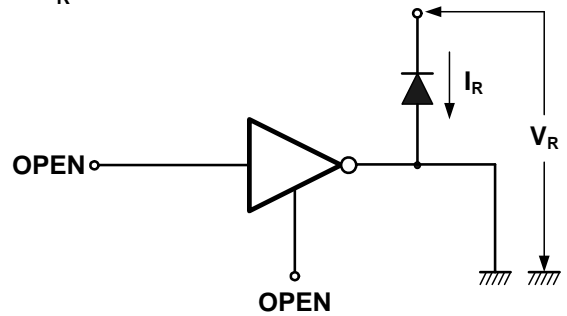

7. V_F

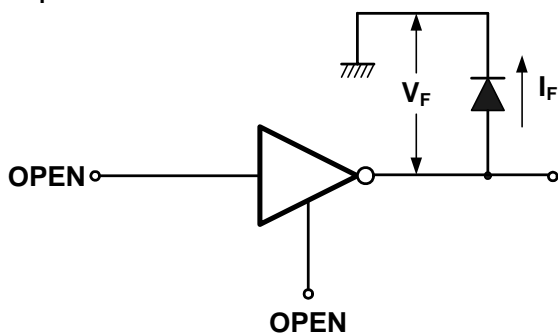

8. t_{ON} , t_{OFF}

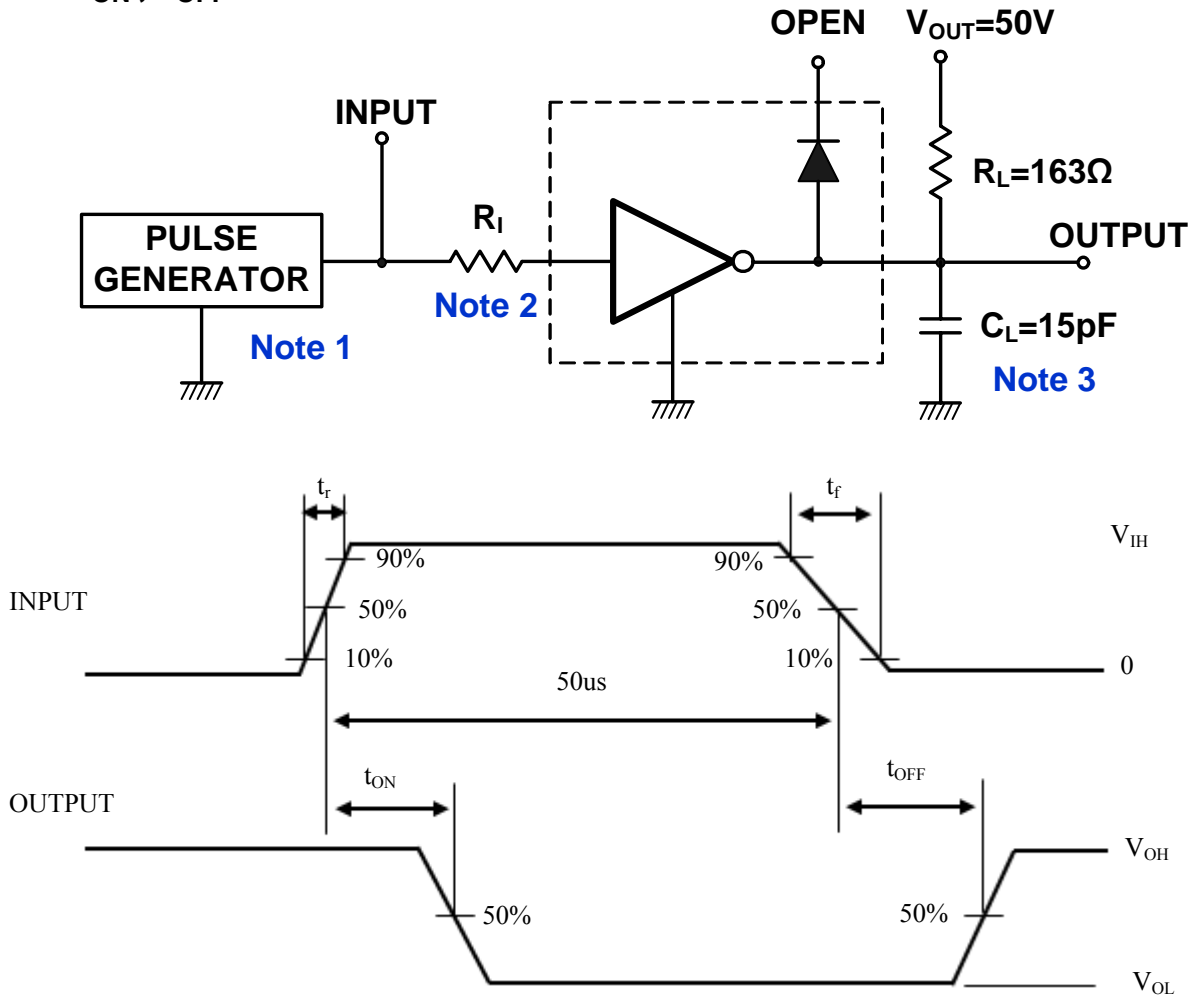

Note 1 : Pulse width 50us, duty cycle 10%
 Output impedance 50Ω, $t_r \leq 5ns$, $t_f \leq 10ns$

Note 2 : See below

Input Condition

Item Code	R_I	V_{IH}
S3771/P	2.7KΩ	3V
S3772/P	0	13V
S3773/P	0	3V
S3774/P	0	8V

Note 3 : CL includes probe and jig capacitance

Precautions for using

This IC does not include built-in protection circuits for excess current or overvoltage. If this IC is subjected to excess current or overvoltage, it may be destroyed. Hence, the utmost care must be taken when systems which incorporate this IC are designed. Utmost care is necessary in the design of the output line, COMMON and GND line since IC may be destroyed due to short-circuit between outputs, air contamination fault, or fault by improper grounding.

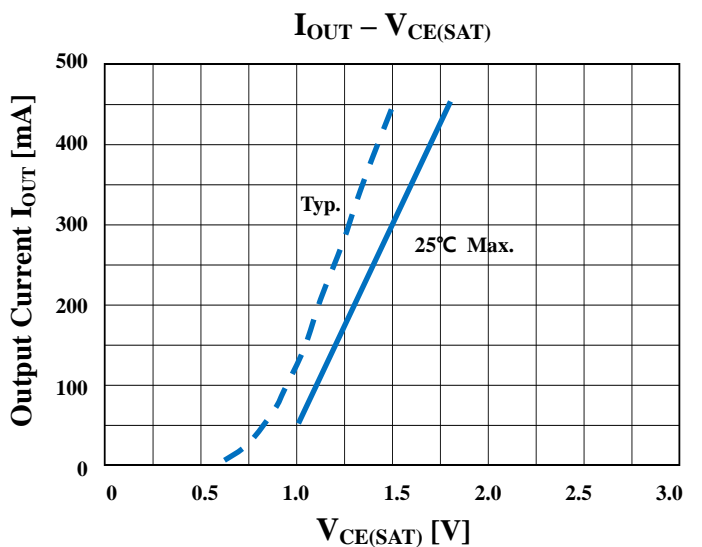
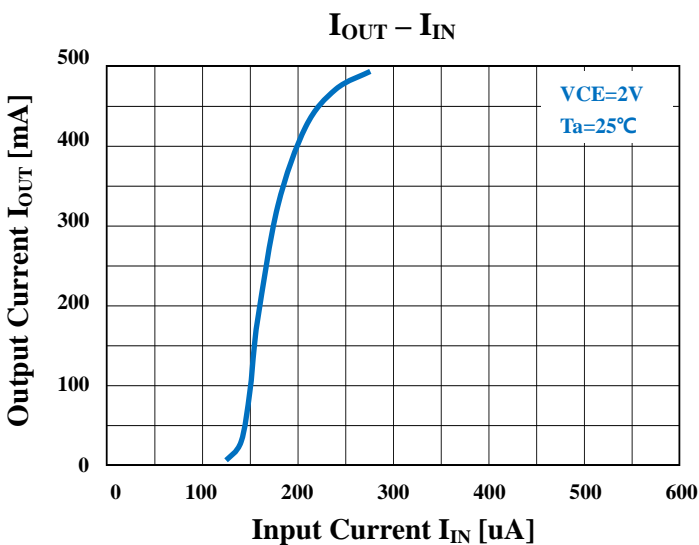
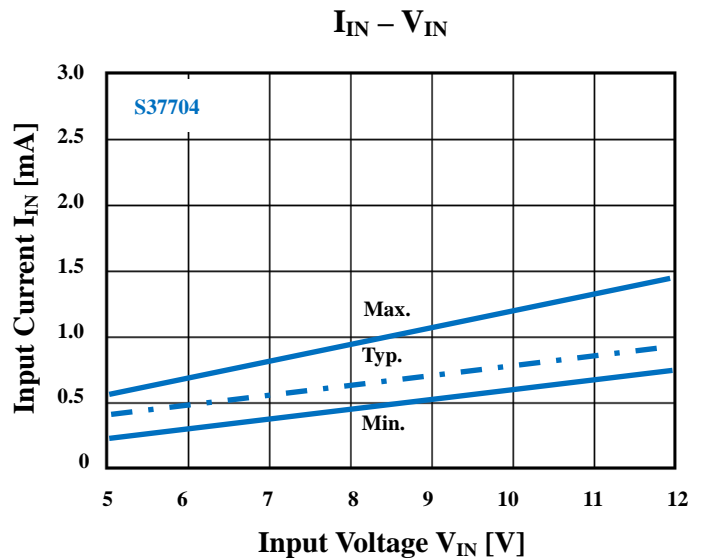
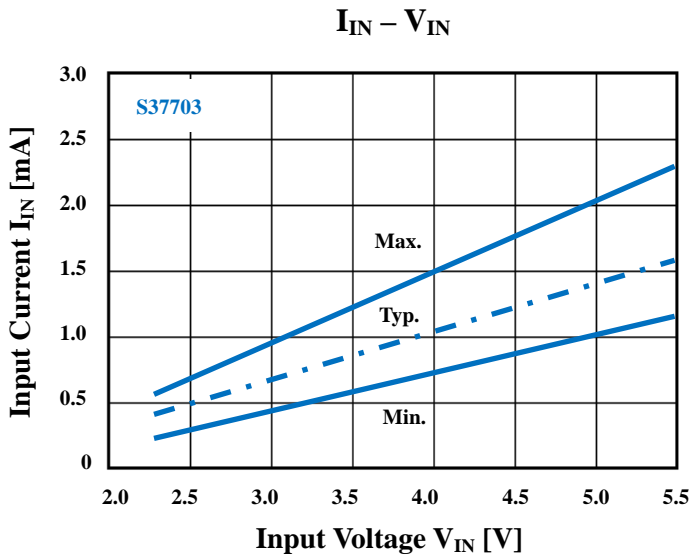
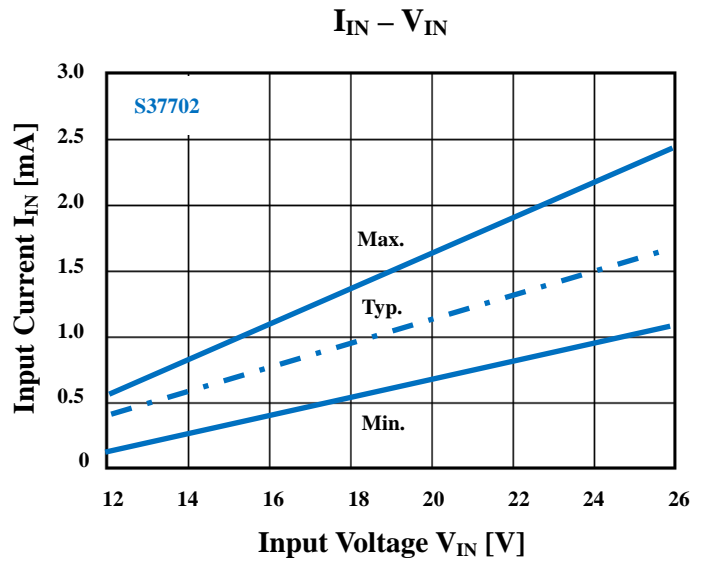
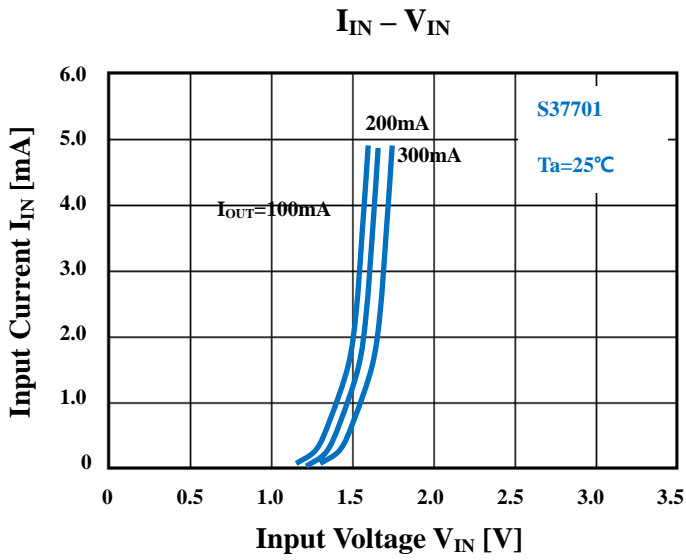

$I_F - V_F$

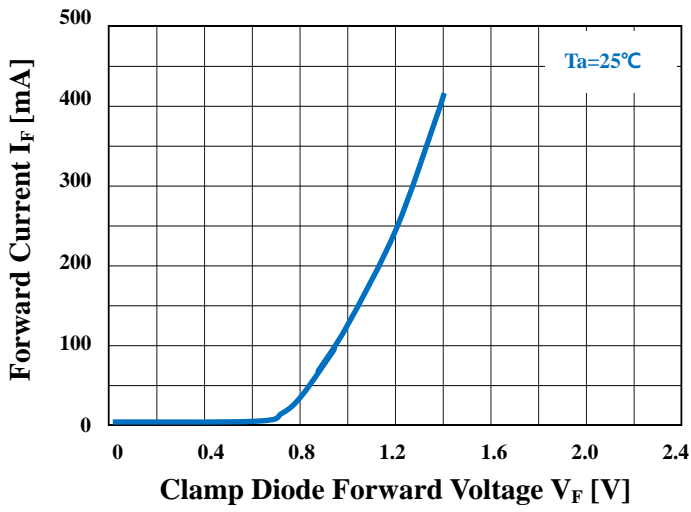

$P_D - T_a$

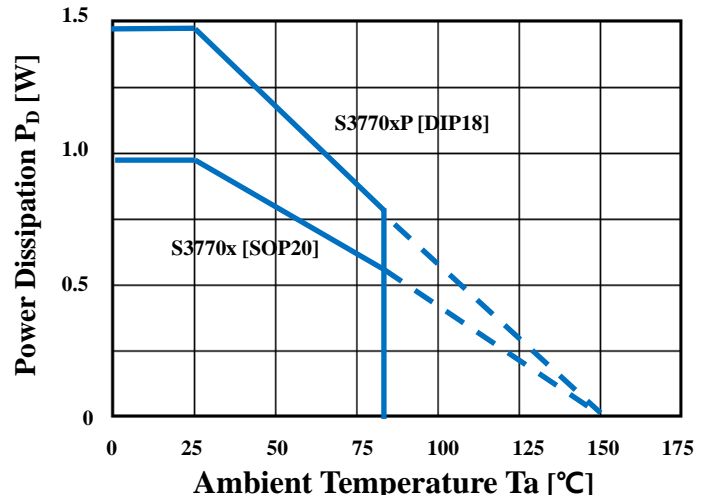

$I_{OUT} - \text{Duty Cycle}$

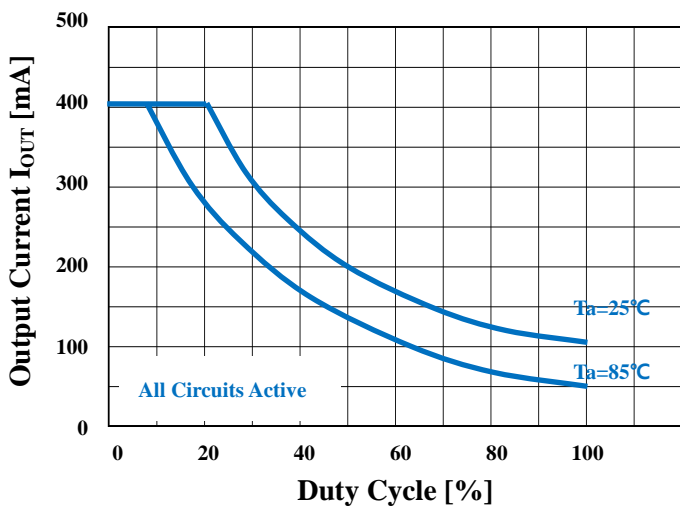

◆ SOP-20 Outline Dimension (Unit : mm)

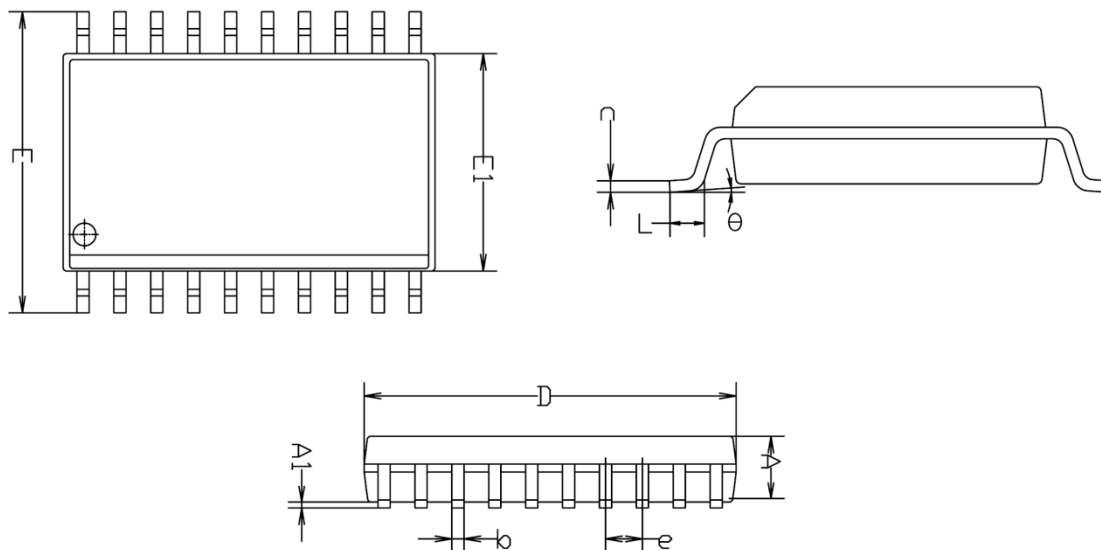

SYMBOL	MILLIMETER(mm)			NOTE
	MINIMUM	NOMINAL	MAXIMUM	
A	2.261	—	2.342	
A1	0.102	0.201	0.300	
b	0.320	0.420	0.520	
c	0.170	0.220	0.270	
D	12.600	12.800	13.000	
E	10.109	10.376	10.643	
E1	7.391	7.493	7.595	
e	1.270 BSC			
L	0.406	—	1.067	
θ	0 °	—	8 °	

※ Recommend PCB solder land [Unit: mm]

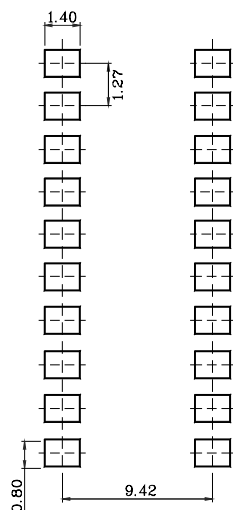

◆ DIP-18 Outline Dimension (Unit : mm)

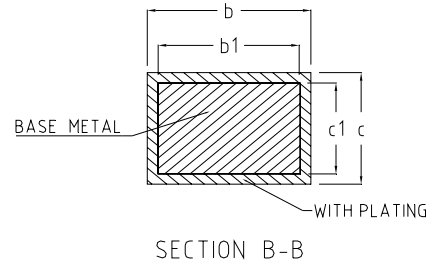
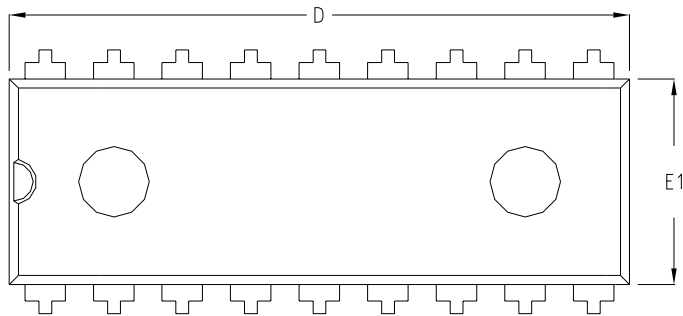
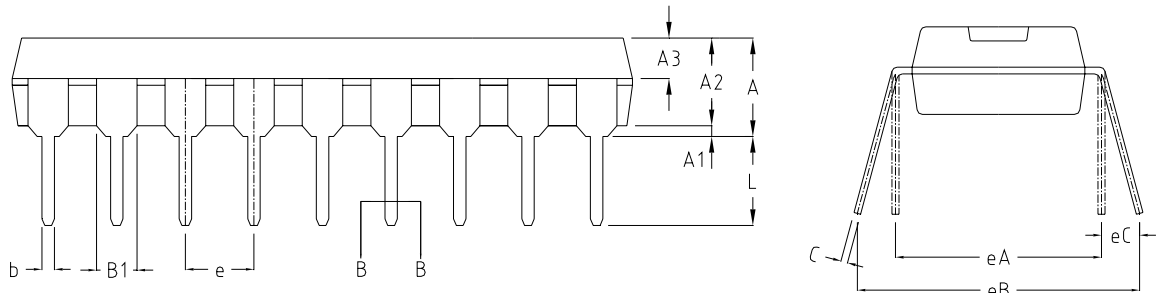

SYMBOL	MILLIMETERS		
	MINIMUM	NOMINAL	MAXIMUM
A	3.60	3.80	4.00
A1	0.51	-	-
A2	3.10	3.30	3.50
A3	1.42	1.52	1.62
b	0.44	-	0.53
b1	0.43	0.46	0.48
B1	1.52BSC		
c	0.25	-	0.31
c1	0.24	0.25	0.26
D	22.70	22.90	23.10
E1	6.40	6.60	6.80
e	2.54BSC		
eA	7.62BSC		
eB	7.62	-	9.50
eC	0	-	0.94
L	3.00	-	-

The AUK Corp. products are intended for the use as components in general electronic equipment (Office and communication equipment, measuring equipment, home appliance, etc.).

Please make sure that you consult with us before you use these AUK Corp. products in equipments which require high quality and / or reliability, and in equipments which could have major impact to the welfare of human life(atomic energy control, airplane, spaceship, transportation, combustion control, all types of safety device, etc.). AUK Corp. cannot accept liability to any damage which may occur in case these AUK Corp. products were used in the mentioned equipments without prior consultation with AUK Corp..

Specifications mentioned in this publication are subject to change without notice.