

**ebm-papst St. Georgen GmbH & Co. KG**

Hermann-Papst-Straße 1

D-78112 St. Georgen

Phone +49 7724 81-0

Fax +49 7724 81-1309

info2@de.ebmpapst.com

www.ebmpapst.com

**Nominal data**

Type	4114 N/2H8P	
Nominal voltage	VDC	24
Nominal voltage range	VDC	16 .. 30
Speed	min <sup>-1</sup>	11000
Power input	W	120
Min. ambient temperature	°C	-20
Max. ambient temperature	°C	75
Air flow	m <sup>3</sup> /h	570
Sound power level	B	8.9
Sound pressure level	dB(A)	78

ml = max. load · me = max. efficiency · rfa = running at free air · cs = customer specs · cu = customer unit  
Subject to alterations

## Technical features

<b>Dimensions</b>	119 x 119 x 38 mm
<b>General description</b>	<p>Particular design features:</p> <p>Very rigid compression curve for high air flow at high counterpressure.          Low operating noise level at high counterpressure.          Standard model with PWM control input and speed signal, other inputs and outputs on request.          Very smooth running 3-phase fan drive.</p> <p>General features:</p> <p>Housing made of aluminium, impeller made of fibreglass-reinforced PA; housing with grounding lug for M4 x 8 screw (Torx).          Protected against reverse polarity and locking.          Connection via single strands AWG 20, sensor and control strands AWG 22, UL1007, TR 64 bared and tin-plated.          Inlet over bars. Rotational direction clockwise looking at rotor.          Mass: 425 g.</p>
<b>Connection line</b>	Single strands AWG 20, sensor and control strands AWG 22, UL 1007, TR 64, bared and tin-plated.
<b>Direction of rotation</b>	Clockwise, looking at rotor
<b>Direction of air flow</b>	Inlet over bars
<b>Bearing</b>	Ball bearings
<b>Lifetime L10 at 40 °C</b>	55000 h
<b>Lifetime L10 at maximum temperature</b>	22500 h
<b>Mass</b>	0.425 kg
<b>Housing material</b>	Aluminum with grounding lug for screw M4 x 8 (TORX).
<b>Material of impeller</b>	Fiberglass-reinforced PA plastic
<b>Motor protection</b>	Protected against reverse polarity and locking.

## Product drawing

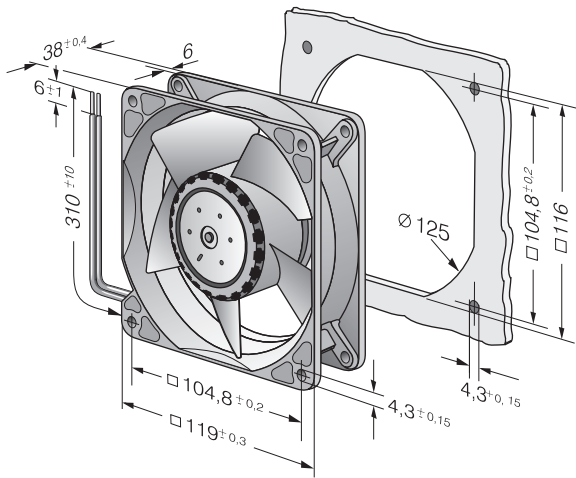

Charts: Air flow

