

M61043FP

3-Battery Version, Reset Pin

REJ03F0065-0100Z

Rev.1.0

Sep.19.2003

Description

The M61043FP is an semiconductor IC device developed for smart battery packs. It incorporates all the analog circuitry required by smart batteries in a single chip. When used in conjunction with a microprocessor, it allows the implementation of a variety of functions, such as battery capacity detection, through the addition of minimal peripheral devices and is ideal for smart battery system (SBS) battery packs.

The M61043FP also has an on-chip overcurrent detect circuit so that the FET for controlling battery charging and discharging is protected regardless of the processing speed of the microprocessor.

The microprocessor can change the amplifier gain of the charge/discharge current detect circuit, so battery capacity detection accuracy is increased. In addition, the M61043FP incorporates a linear regulator that allows it to function as the power supply for the microprocessor, thereby simplifying power supply block design.

Features

- On-chip high-gain op-amp for monitoring charge and discharge current.
- On-chip overcurrent detect circuit to protect FET.
- Charge/discharge FET can be controlled from microprocessor.
- Power-save function for reducing current consumption.
- 5.2 V operation to reduce microprocessor current consumption.
- High-voltage device (absolute maximum rating: 33 V).

Application

Smart battery system (SBS) battery packs

Pin Connection Diagram (Top View)

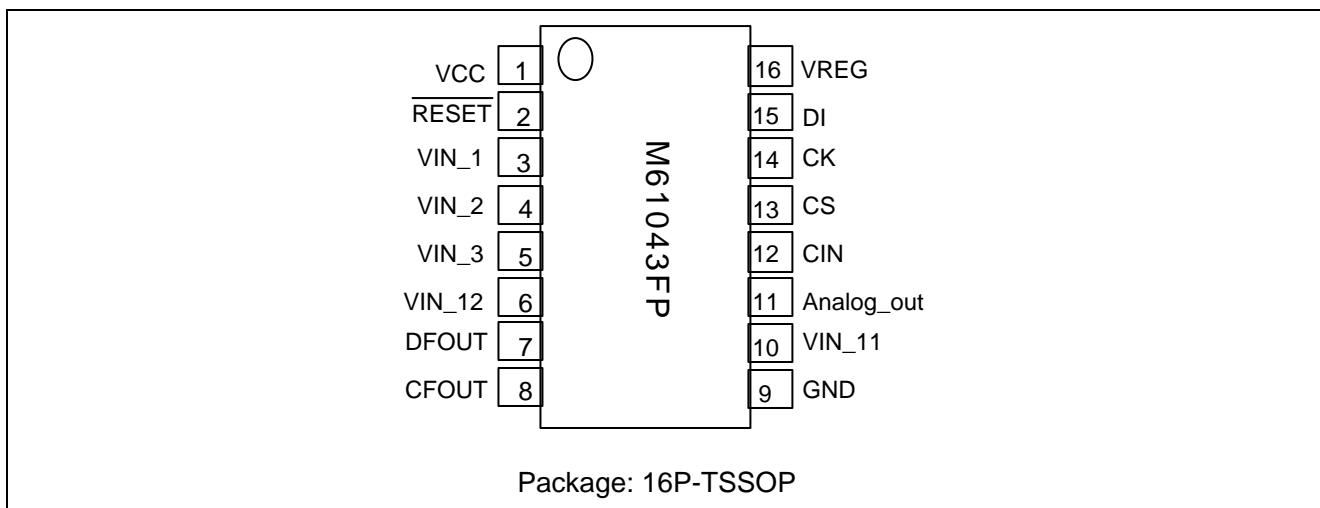

Block Diagram

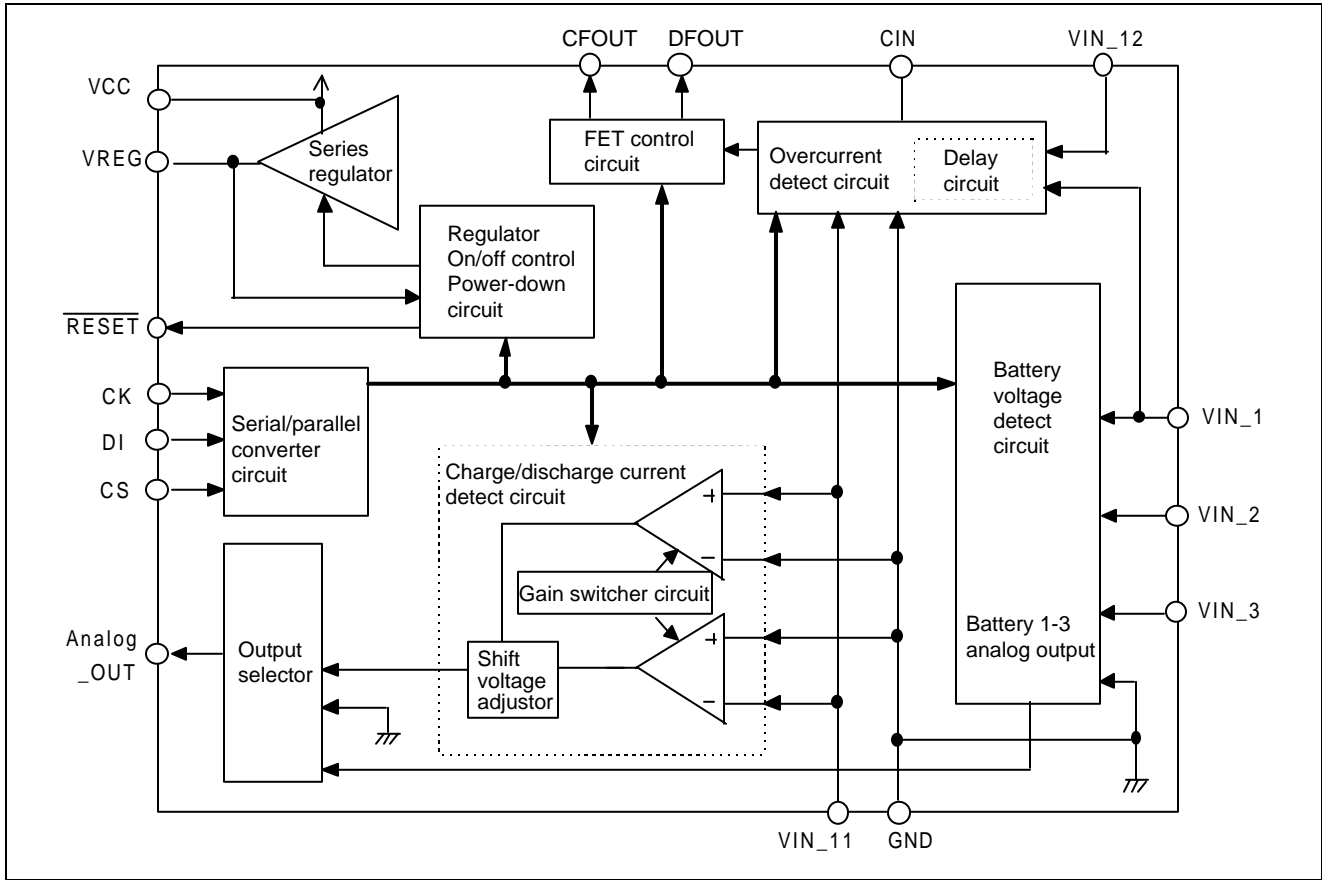

Pin Function**Table 1**

Pin No.	Symbol	Function
1	Vcc	The chip's power supply pin. Power is supplied by the charger or the battery.
2	RESET	Output pin for microprocessor reset signal.
3	VIN_1	Positive input pin for lithium ion battery 1.
4	VIN_2	Negative input pin for lithium ion battery 1. Positive input pin for lithium ion battery 2.
5	VIN_3	Negative input pin for lithium ion battery 2. Positive input pin for lithium ion battery 3.
6	VIN_12	Charger connect monitor pin. Detects changes from power-down status.
7	DFOUT	Output pin for discharge FET on/off signals. Also turns off when overcurrent detected.
8	CFOUT	Output pin for charge FET on/off signals.
9	GND	Ground pin. Negative input pin for lithium ion battery 3. Connected to charge/discharge current sensor resistor.
10	VIN_11	Charge/discharge current monitor pin. Connected to charge/discharge current sensor resistor.
11	Analog_OUT	Output pin for analog signals.
12	CIN	Capacity connection pin for setting overcurrent prevention delay time.
13	CS	When this pin is low level, data input is accepted and data can be stored in a 6-bit shift register. At the rising edge from low to high the value in the 6-bit shift register is latched.
14	CK	Shift clock input pin. At the rising edge to high the input signal from the DI pin is input to the 6-bit shift register.
15	DI	Shift data input pin. Serial data with a data length of 6 bits may be input via this pin.
16	Vreg	Power supply pin for microprocessor. Power can be shut off using a signal from the microprocessor.

Operation

The M61043FP is an semiconductor IC device developed for smart battery packs. It is ideal for smart battery system (SBS) battery packs that consist of four lithium ion batteries connected in series. A high-voltage device, it is suitable for use with a wide variety of charger systems.

It incorporates all the analog circuitry required by smart batteries in a single chip. When used in conjunction with a microprocessor, it allows the implementation of a variety of functions, such as battery capacity detection, through the addition of minimal peripheral devices. The functions of the M61043FP are described below.

1. Battery Voltage Detect Circuit

The M61043FP can output the voltage levels of the batteries connected in series via the Analog_out pin. An on-chip buffer amplifier monitors the pin voltages of the batteries. Offset voltage correction using adjustment by the microprocessor is also supported. The M61043FP is configured to detect the battery voltage using a microprocessor driven using a power supply voltage of 5.2 V.

2. Charge/Discharge Current Detect Circuit

SBS requires a function for monitoring the battery capacity. The M61043FP uses an on-chip amplifier to monitor battery capacity based on a drop in the voltage of an external sensor resistor. In this way, the charge/discharge current is converted into a voltage.

The voltage amplification ratio can be adjusted from the microprocessor. In addition, the current output shift voltage can be adjusted from the microprocessor, widening the allowable dynamic range of the A/D converter.

3. Overcurrent Detect Circuit

The M61043FP has an on-chip overcurrent detect circuit. If an excessive current flows from the lithium ion batteries, the discharge control FET is shut off after a set delay time, halting discharge. This makes the battery pack safer. The delay time can be set using an external capacitor. It is possible to determine the overcurrent detect status by monitoring the CIN pin. The overcurrent detect circuit provides protection regardless of the processing speed of the microprocessor.

4. Series Regulator

The M61043FP has an on-chip low-dropout series regulator. It can be used as the power supply for the microprocessor, thereby simplifying power supply block design.

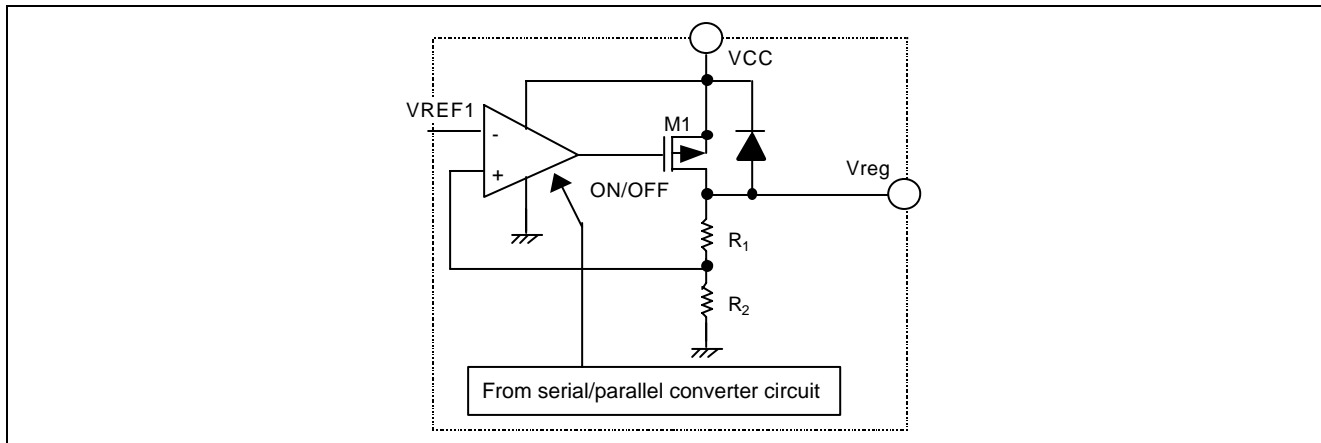

Figure 3 Series Regulator

5. Reset Circuit

The reset circuit of the M61041FP monitors the voltage of the Vreg pin. If the power supply voltage of the microprocessor drops the reset circuit operates, preventing microprocessor runaway. Microprocessor runaway is avoided because the microprocessor is reset if the battery pack left standing and the battery voltage is allowed to drop. This enhances the safety of battery packs that are left unused.

In addition, reset circuit monitors the voltage of the Vreg pin when the battery pack is connected to the charger, ensuring that a reset will be applied if the voltage supplied to the microprocessor becomes excessively small. This helps to guarantee reliable operation.

6. Power-Save Function

The M61043FP is equipped with a power-save function.

When the battery voltage is being monitored a portion of the charge/discharge current monitor circuit automatically stops operating, and when the charge/discharge current is being monitored the battery voltage monitor circuit automatically stops operating. This helps prevent unnecessary power consumption. In addition, current consumption is further reduced by setting the analog output selector to ground potential output when in the standby mode.

Transition to Power-Down Mode

When the microprocessor determines that the battery voltage has dropped it sends a power-down instruction via the interface circuit. When it receives the instruction, the M61043FP's DFOUT pin switches to high voltage. In addition, the VIN_12 pin is pulled down to low level by an internal resistor. When the VIN_12 pin goes to low potential after reception of the power-down instruction, output from the series regulator stops, switching the M61043FP into power-down mode.

At this point the operation of the circuitry is completely halted. In this status CFOUT is high level and DFOUT is high level (external charge/discharge prohibited status). The maximum current consumption of the M61043FP is 1.0 μ A in order to prevent any further drop in the battery voltage.

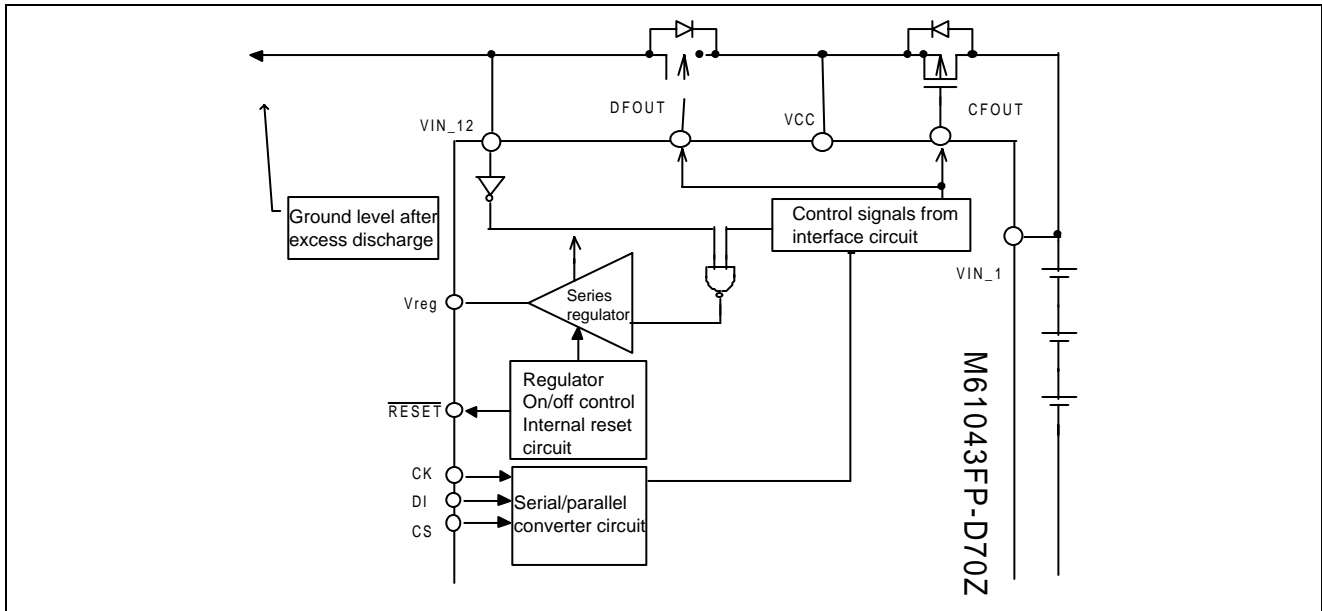

Figure 4 Operation After Excess Discharge Detection

Cancellation of Power-Down Mode

If the battery pack is connected to a charger when the M61043FP is in the power-down mode (VIN_12 becomes high level), the series regulator immediately begins to operate. The power-down mode is canceled, and once again the M61043FP is ready to receive instructions from the microprocessor.

Absolute Maximum Ratings

Table 2

Item	Symbol	Rated Value	Unit	Conditions
Absolute maximum rating	Vabs	33	V	
Power supply voltage	Vcc	30	V	
Allowable loss	PD	500	mW	
Ambient operating temperature	Topr	-20 to +85	°C	
Storage temperature	Tstg	-40 to +125	°C	

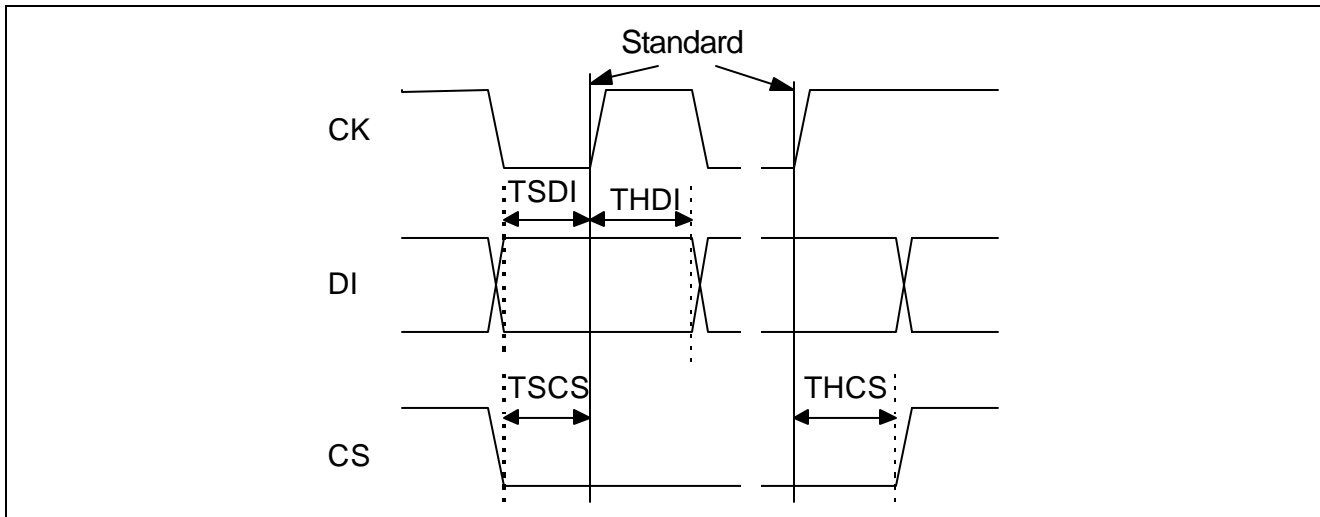

Figure 5 Interface Block Timing Definitions

Electrical Characteristics

Table 3

(Ta = 25°C, Vcc = 14 V unless otherwise specified)

Block	Item	Symbol	Rated Value			Unit	Circuit	Command	Conditions
			Min.	Typ.	Max.				
All	Power supply voltage	Vsup	—	—	30	V	1	—	
	Circuit current 1	Isup1	60	150	215	μA	1	1	During charge/discharge current monitoring
	Circuit current 2	Isup2	55	140	200	μA	1	2	During battery voltage monitoring
	Circuit current 3	Isup3	25	80	115	μA	1	3	During ground output (initial status)
	Circuit current (power-down mode)	l _{pd}	—	—	0.5	μA	1	4	All circuits halted, VIN_12 = GND
Regulator	Output voltage	Vreg	5.075	5.2	5.325	V	2	—	Vcc = 14V, I _{out} = 20mA
	Input stability	ΔV _{out10}	—	60	100	mV	2	—	Vcc = 6.2V to 24V, I _{out} = 20mA
	Load stability	ΔV _{out20}	—	30	50	mV	2	—	Vcc = 6.2V, I _{out} = 0.1mA to 20mA
	Input voltage (VCC pin)	VIN0	6.2	—	30	V	2	—	
	Reset detect voltage 1	V _{det-}	3.000	3.200	3.400	V	2	—	
	Reset cancel voltage 1	V _{det+}	4.100	4.200	4.300	V	2	—	
Overcurrent detect	Overcurrent prevention voltage 1	V _{d1}	0.18	0.2	0.22	V	3	5	
	Overcurrent prevention voltage 2	V _{d2}	V _{cc} /3 × 0.6	V _{cc} /3	V _{cc} /3 × 1.4	V	4	5	Load short detected
	Overcurrent prevention delay time 1	T _{vd1}	7	10	15	ms	3	5	CICT = 0.01μF
	Overcurrent prevention delay time 2	T _{vd2}	150	250	350	μs	4	5	
Battery voltage detect	Input offset voltage 1	V _{off1}	31	206	385	mV	5	6	
	Voltage amplification ratio 1	G _{amp1}	0.99	1.00	1.01	—	5	7	
	Output source current capacity	I _{source1}	150	—	—	μA	6	8	
	Output sink current capacity	I _{sink1}	150	—	—	μA	6	9	
	Maximum detect battery voltage	V _{mo_max}	4.64	—	—	V	5	—	(Vreg - V _{off1})/G _{amp1}

Block	Item	Symbol	Rated Value			Unit	Circuit	Command	Conditions
			Min.	Typ.	Max.				
Charge/discharge current detect	Input offset voltage	Voff2	1.0	2.4	3.8	V	7	10*	Gain = 200
	Voltage amplification ratio 21	Gain21	38.4	40	41.6		7	11*	
	Voltage amplification ratio 22	Gain22	96	100	104		7	12*	
	Voltage amplification ratio 23	Gain23	192	200	208		7	13*	
	Current output shift voltage 1	Vios1	0.96	1.04	1.12	V	7	14*	
	Current output shift voltage 2	Vios2	1.93	2.08	2.23	V	7	15*	
	Current output shift voltage 3	Vios3	2.91	3.12	3.33	V	7	16*	
	Current output shift voltage 4	Vios4	3.49	3.74	3.99	V	7	17*	
	Output source current capacity	Isource2	150	—	—	μA	8	18*	
	Output sink current capacity	Isink2	150	—	—	μA	8	18*	
Interface	DI input H voltage	VDIH	Vreg-0.5	—	Vreg	V	9	—	
	DI input L voltage	VDIL	0	—	0.5	V	9	—	
	CS input H voltage	VCSH	Vreg-0.5	—	Vreg	V	9	—	
	CS input L voltage	VCSL	0	—	0.5	V	9	—	
	CK input H voltage	VCKH	Vreg-0.5	—	Vreg	V	9	—	
	CK input L voltage	VCKL	0	—	0.5	V	9	—	
	DI setup time	TSDI	600	—	—	ns	9	—	
	DI hold time	THDI	600	—	—	ns	9	—	
	CS setup time	TSCS	600	—	—	ns	9	—	
CS hold time	THCS	600	—	—	ns	9	—		

Refer to figures 1 to 9 for the circuits and to table 4 for the command sequences used for measurement.

* For the charge/discharge current detect block, different command sequences are used during charging and discharging.

Measurement Circuit Diagrams

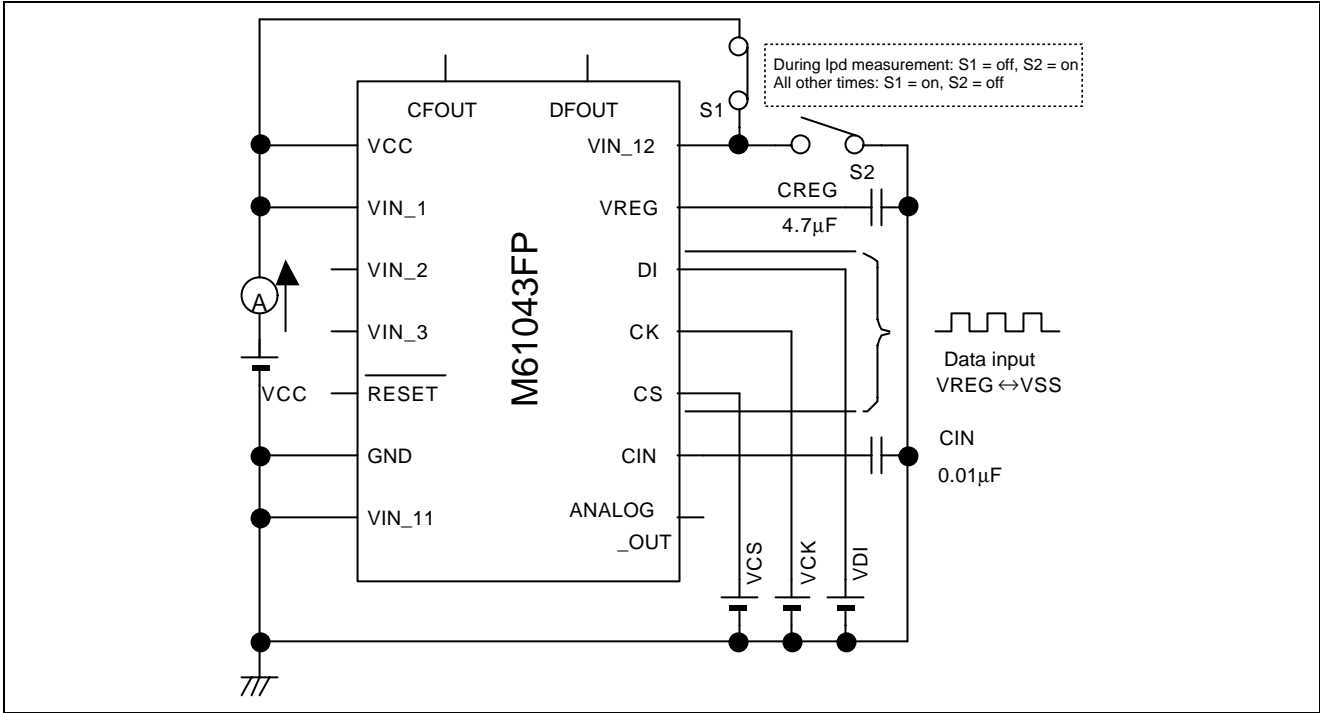

Circuit 1

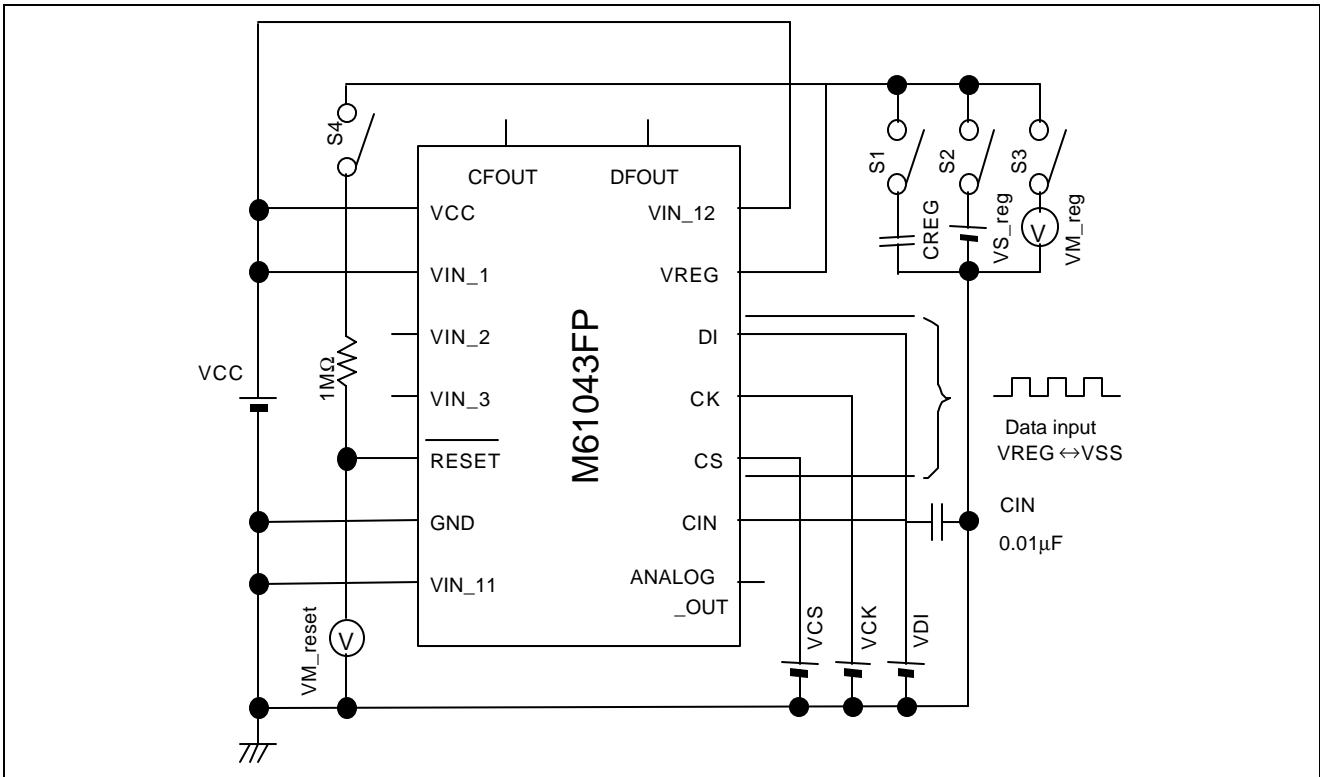

Circuit 2

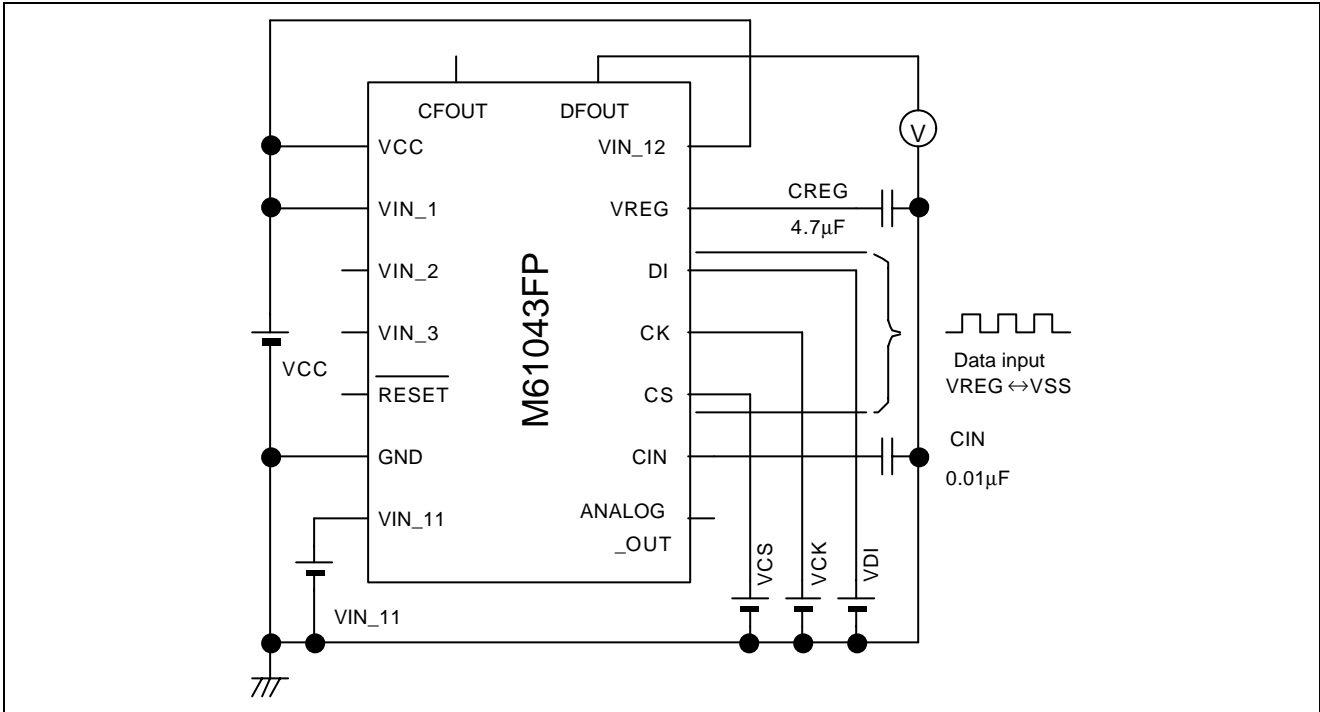

Circuit 3

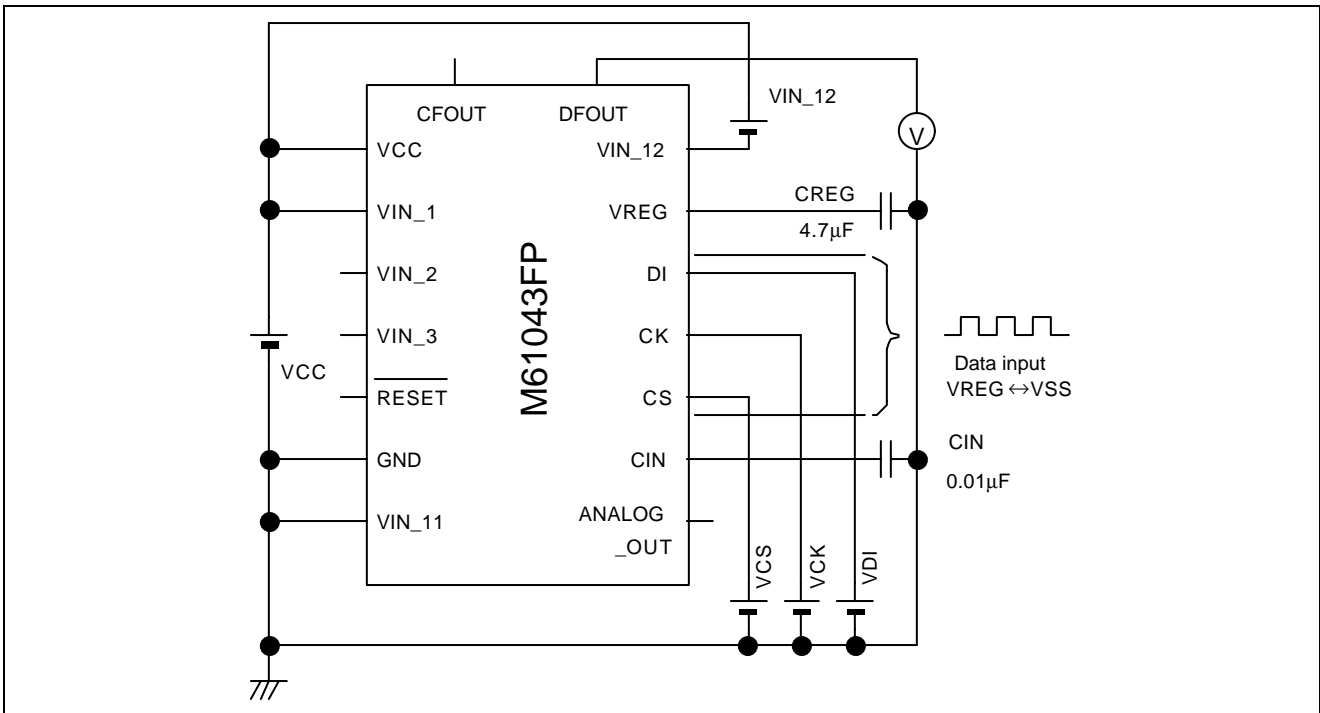

Circuit 4

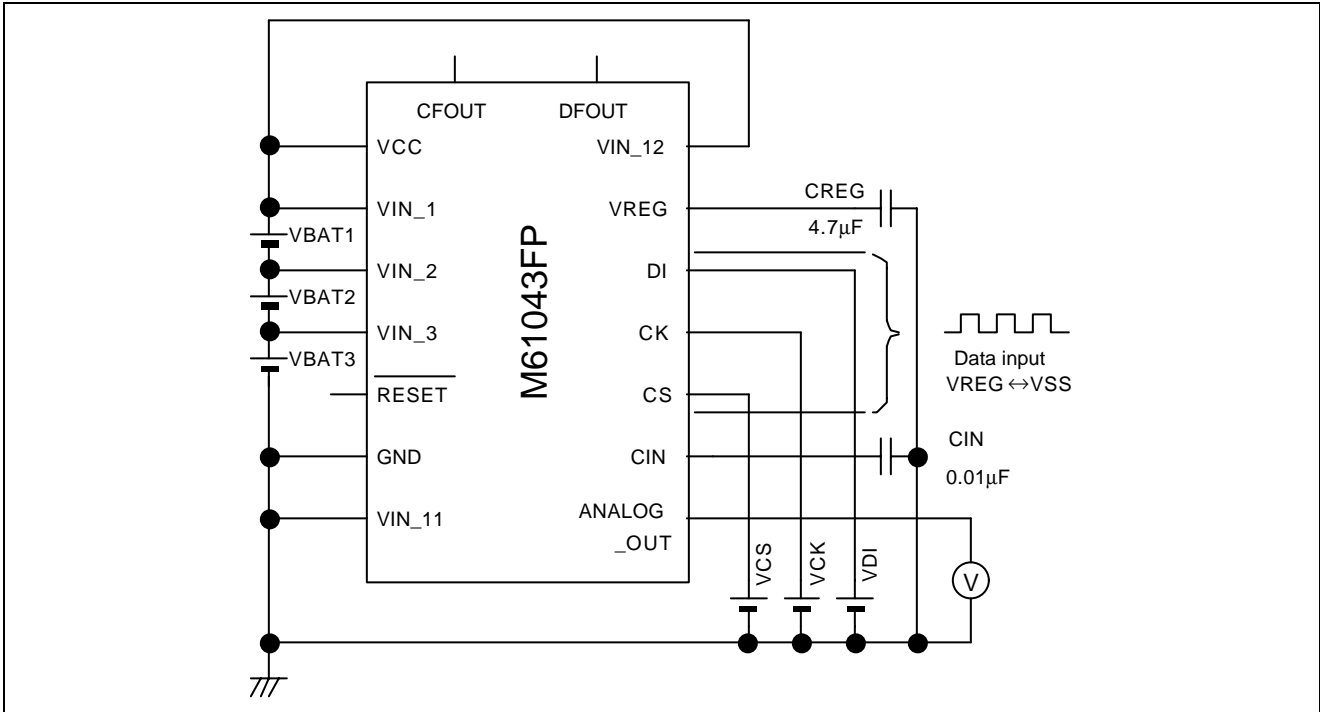

Circuit 5

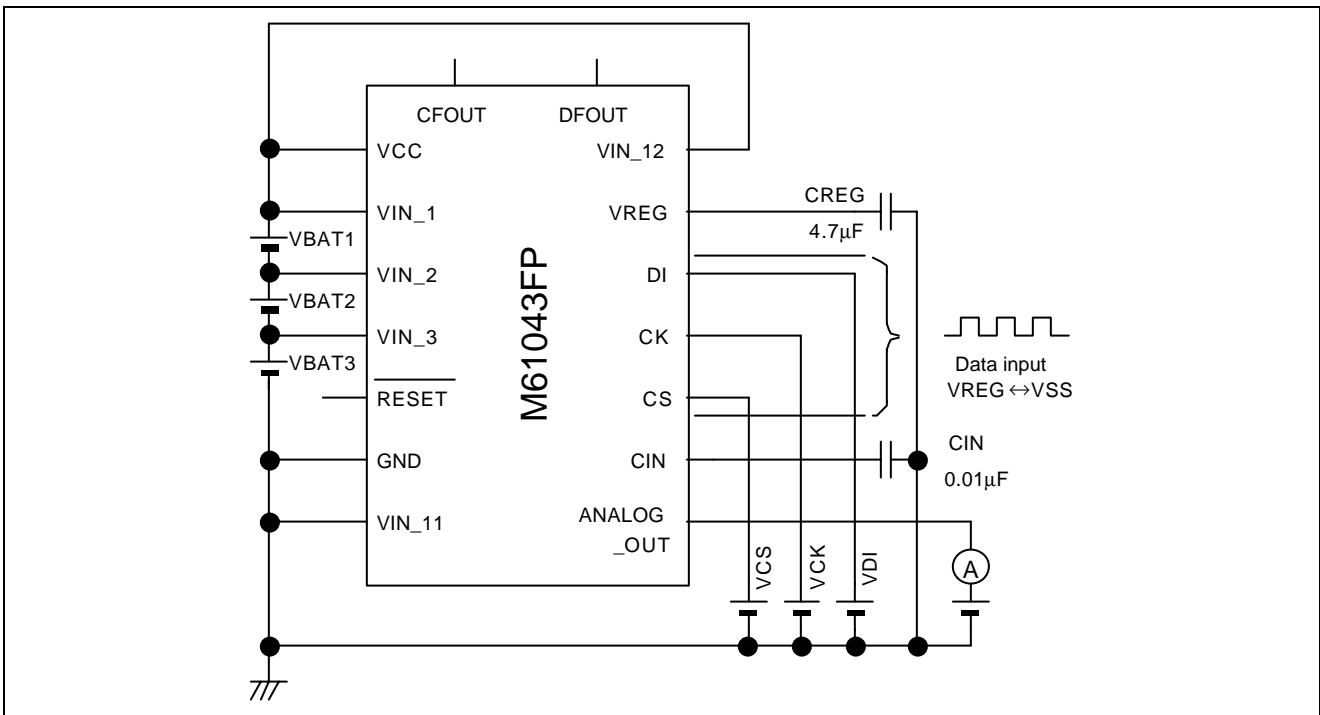

Circuit 6

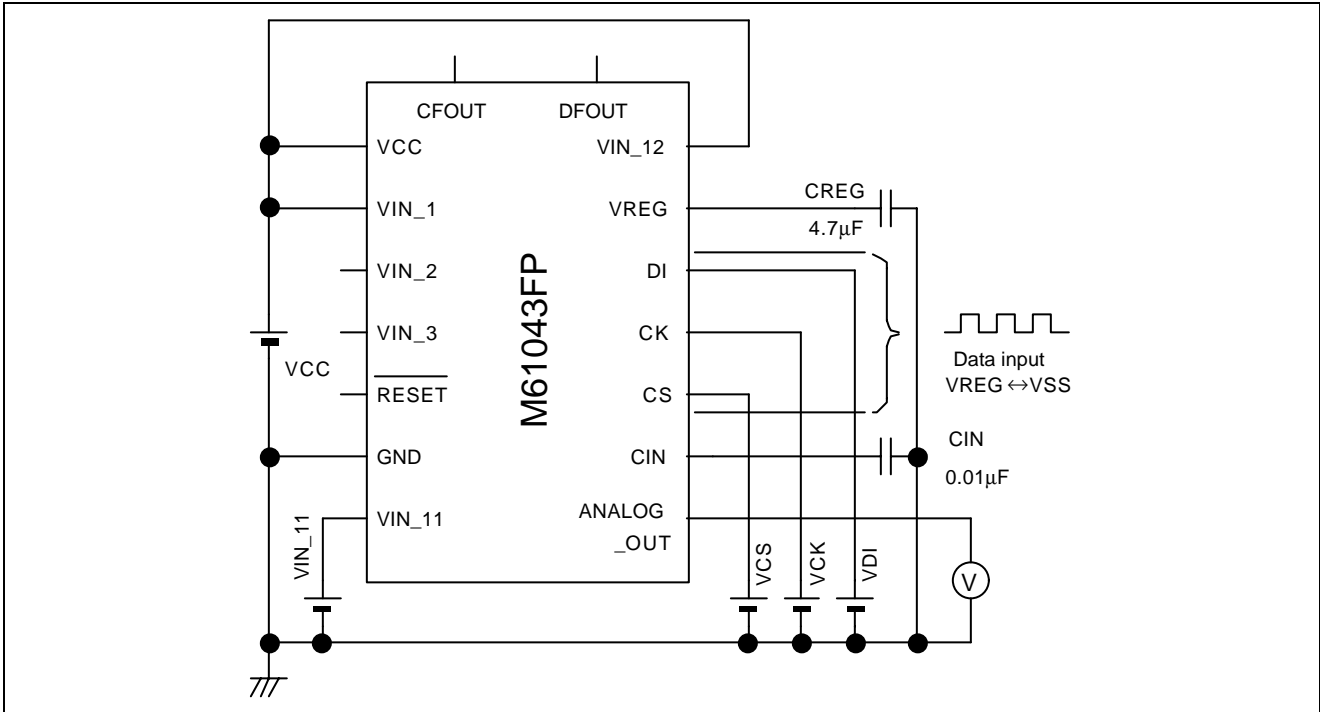

Circuit 7

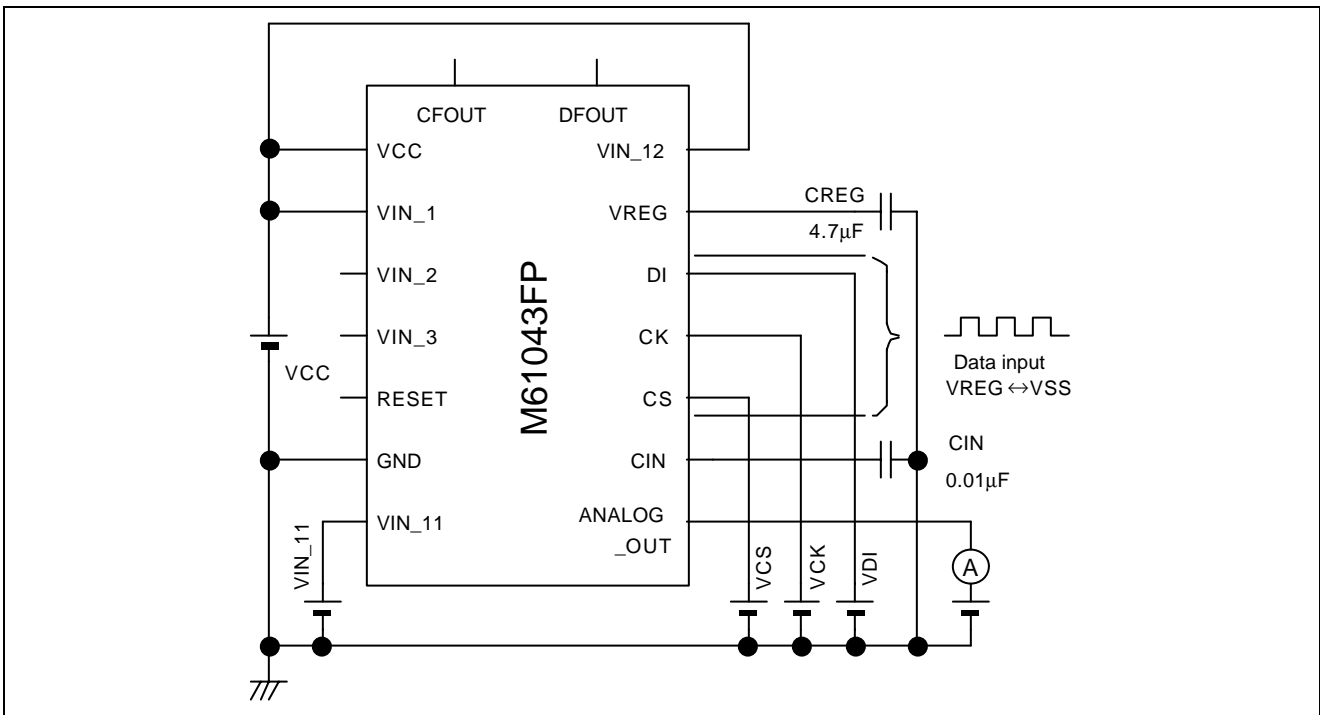

Circuit 8

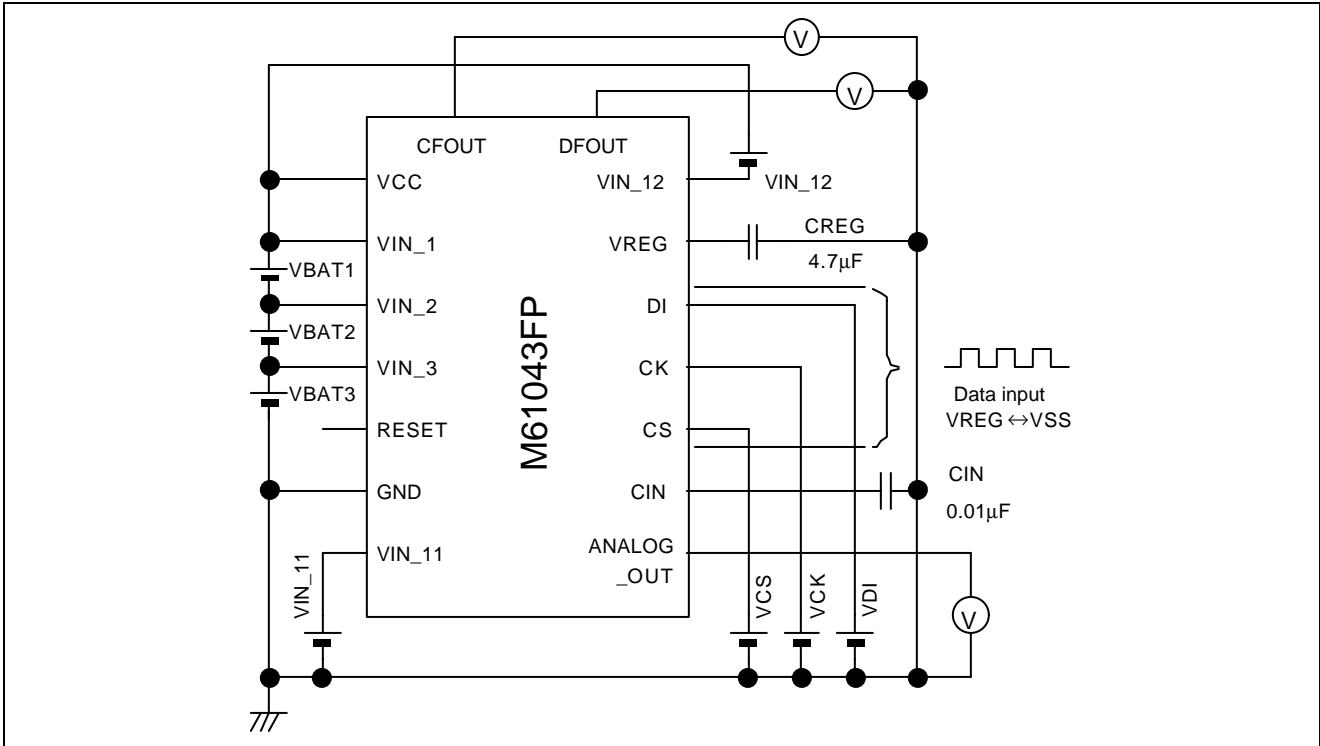

Circuit 9

Table 4 Command Sequences Used for Measuring Rated Values

No	Command Sequence	VIN_11 Input
1	(00) ₈ → (24) ₈ → (31) ₈ → (43) ₈ → (52) ₈	90mV
2	(00) ₈ → (10) ₈ → (43) ₈ → (51) ₈	0mV
3	(00) ₈	0mV
4	(00) ₈ → (71) ₈	0mV
5	(00) ₈ → (43) ₈	0mV
6	(00) ₈ → (51) ₈ → (14) ₈ → (15) ₈ → (16) ₈ → (17) ₈	0mV
7	(00) ₈ → (51) ₈ → (10) ₈ → (11) ₈ → (12) ₈ → (13) ₈	0mV
8	(00) ₈ → (51) ₈ → (13) ₈	0mV
9	(00) ₈ → (51) ₈ → (17) ₈	0mV
10	(00) ₈ → (43) ₈ → (52) ₈ → (37) ₈	0mV
11	(00) ₈ → (43) ₈ → (52) ₈ → (31) ₈ → (35) ₈	90mV
12	(00) ₈ → (43) ₈ → (52) ₈ → (32) ₈ → (36) ₈	45mV
13	(00) ₈ → (43) ₈ → (52) ₈ → (33) ₈ → (37) ₈	7mV
14	(00) ₈ → (43) ₈ → (52) ₈ → (31) ₈ → (24) ₈	90mV
15	(00) ₈ → (43) ₈ → (52) ₈ → (31) ₈ → (25) ₈	90mV
16	(00) ₈ → (43) ₈ → (52) ₈ → (31) ₈ → (26) ₈	90mV
17	(00) ₈ → (43) ₈ → (52) ₈ → (31) ₈ → (27) ₈	90mV
18	(00) ₈ → (43) ₈ → (52) ₈ → (31) ₈	45mV

- Notes :
1. Indications such as (00)₈ show the address and data, in that order, of the serial data from the microprocessor in octal notation.
 2. Numbers 10 to 17 are command sequences used during charging. For the commands used during discharging, substitute (53)₈ for (52)₈.
 3. During measurement, the voltage listed in table 4 should be input to VIN_11. When measuring during charging, the specified voltage should be input to VIN_11 as a negative voltage. The specified voltage should be input to VIN_11 as a positive voltage during discharging.

Description of Circuit Blocks

(1) Battery Voltage Detect Circuit

As shown in figure 6, the battery voltage detect circuit block of the M61043FP consists of switches, a buffer amplifier, a reference voltage circuit, and a logic circuit.

When the voltage to be detected is selected, based on serial data from the microprocessor, the appropriate switch connections are determined by the logic circuit. The voltages Vbat1, Vbat2, and Vbat3 from the batteries connected to the M61043FP, multiplied by Gamp1 (1.0), are output from the Analog_out pin. It is also possible to output an offset voltage.

In the power-save mode all the switches are turned off, so the current consumption of this circuit block is zero.

Note : The settling time of this circuit block after voltage changes is about 50 μs.

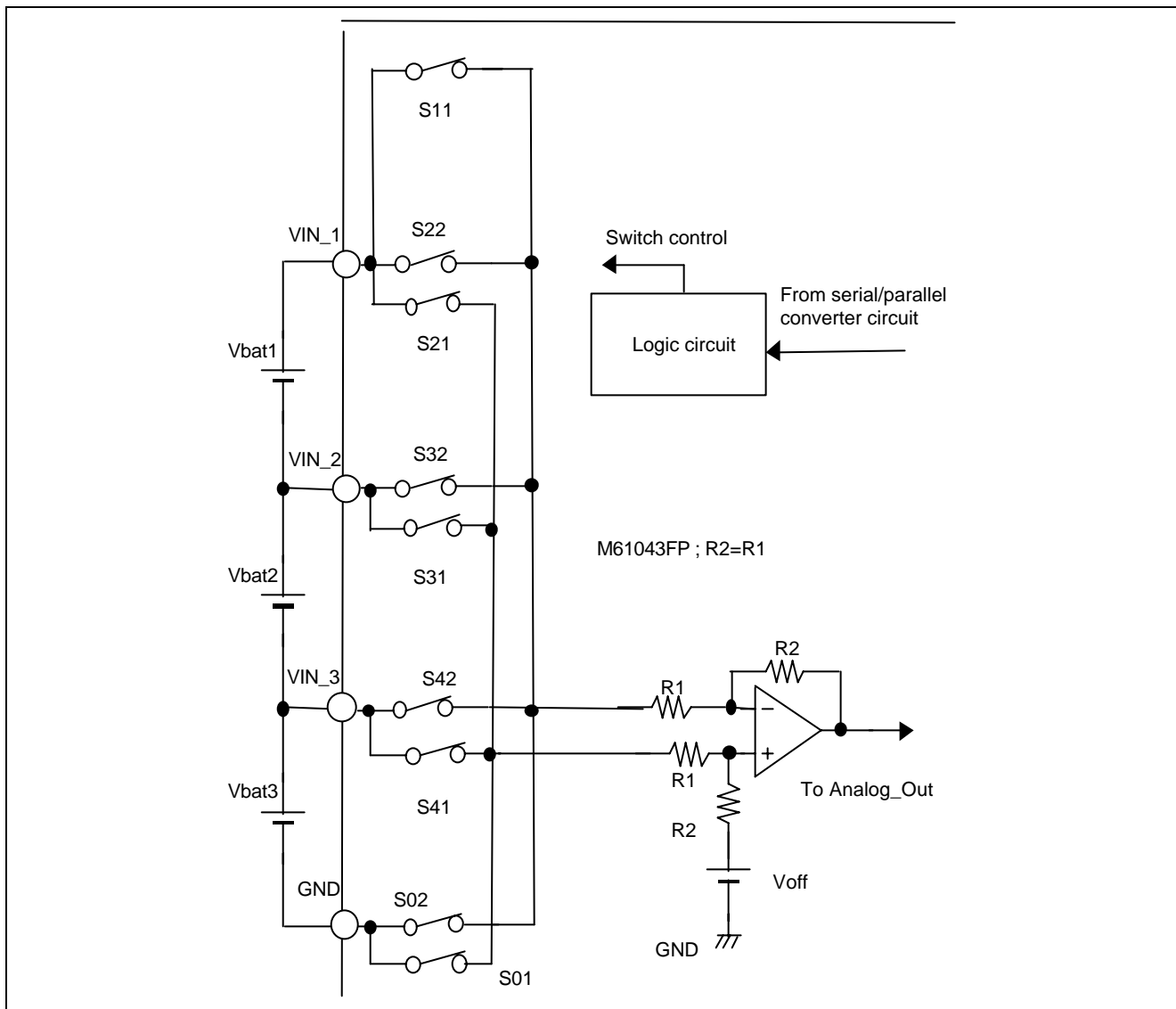

Figure 6 Battery Voltage Detect Circuit

Battery Voltage Monitoring Method

To select battery voltage detection, serial data (51)₈ is sent from reset status (00)₈. The V1 battery voltage (Vin1) is output from the analog output pin by sending (10)₈. Next, (15)₈ is sent to switch the analog output pin from the V1 battery voltage to the V1 offset voltage (Voff1). The actual voltage (Vbat1) can be obtained by the microprocessor by calculating $V_{bat1} = (Vin1 - Voff1) / G_{amp}$. The same method can be used for Vbat2 and Vbat3 in order to monitor the battery voltage with a high degree of accuracy.

(2) Charge/Discharge Current Detect Block

As shown in figure 7, the charge/discharge current detect block of the M61043FP consists of a preamplifier current output shift voltage adjustment circuit, a buffer amplifier, and dividing resistors.

The voltage difference indicated by the sensor resistor is amplified to the ground reference voltage by the preamplifier. The gain can be switched using serial signals from the microprocessor. The output is impedance converted by the buffer amplifier.

It is also possible to switch the current detect shift voltage using the microprocessor.

Charge Current Monitoring Method

Serial data (43)₈ is sent from reset status to turn on the discharge control FET. When the charger is connected in this status a current flows between the VIN_11 pin and the GND pin (across the RSENSE sensor transistor), causing the voltage Vin1 to be generated. Sending (52)₈ switches the output of the analog output pin to charge current output. At this point the amplifier used for monitoring the charge current is still off, so the analog output pin outputs ground potential. Next, a value between (35)₈ and (37)₈ is selected to switch the amplifier's amplification ratio. In this way the amplification ratio of the amplifier used for monitoring the charge current is switched to GainC. At this point the voltage of the analog output pin is the offset voltage of the charge current monitor amplifier (VoffC).

If the offset voltage VoffC is higher than the value listed in table 5, the shift voltage select command between (24)₈ and (27)₈ that corresponds to VoffC is sent and once again the offset voltage is measured, this time as VoffC_S. Next, a value between (31)₈ and (33)₈ is selected to switch the current monitor amplifier's amplification ratio. At this point the voltage of the analog output pin is VaoutC. It is possible to calculate the charge current based on the analog output pin voltages resulting from the above settings. When calculating the current value, VoffC_S offset and VaoutC current monitor values measured using the same amplification ratio should be used. Table 6 is a list of the measurable current values.

$$I_{cha} \text{ (charge current)} = Vin1 \div RSENSE \text{ (sensor resistor value)} \dots (1)$$

$$VaoutC - VoffC_S = Vin1 \times GainC \dots (2)$$

Based on (1) and (2) it is possible to calculate the charge current.

$$I_{cha} \text{ (charge current)} = (VaoutC - VoffC_S) \div GainC \div RSENSE$$

Discharge Current Monitoring Method

Serial data (43)₈ is sent from reset status to turn on the discharge control FET. When a load is connected in this status a current flows between the VIN_11 pin and the GND pin (across the RSENSE sensor transistor), causing the voltage Vin1 to be generated. Sending (53)₈ switches the output of the analog output pin to discharge current output. At this point the amplifier used for monitoring the discharge current is still off, so the analog output pin outputs ground potential. Next, a value between (35)₈ and (37)₈ is selected to switch the amplifier's amplification ratio. In this way the amplification ratio of the amplifier used for monitoring the discharge current is switched to GainD. At this point the voltage of the analog output pin is the offset voltage of the discharge current monitor amplifier (VoffD).

If the offset voltage VoffD is higher than the value listed in table 5, the shift voltage select command between (24)₈ and (27)₈ that corresponds to VoffD is sent and once again the offset voltage is measured, this time as VoffD_S. Next, a value between (31)₈ and (33)₈ is selected to switch the current monitor amplifier's amplification ratio. At this point the voltage of the analog output pin is VaoutD. It is possible to calculate the discharge current based on the analog output pin voltages resulting from the above settings. When calculating the current value, VoffD_S offset and VaoutD current monitor values measured using the same amplification ratio should be used. Table 6 is a list of the measurable current values.

$$I_{dis} \text{ (discharge current)} = Vin1 \div RSENSE \text{ (sensor resistor value)} \dots (1)$$

$$VaoutD - VoffD_S = Vin1 \times GainD \dots (2)$$

Based on (1) and (2) it is possible to calculate the discharge current.

$$I_{dis} \text{ (discharge current)} = (VaoutD - VoffD_S) \div GainD \div RSENSE$$

Discharge Current Measurable Range

The range of discharge current values that can be measured is determined by the sensor resistor value, the Vreg voltage, and the amplification ratio of the current monitor amplifier. Refer to table 6 for details. The current value is proportional to the sensor resistor value, so if the sensor resistor value changes it is possible to determine the new measurable range of current values by multiplying the sensor resistor value by the current coefficient value listed in table 6.

Table 5 Shift Voltage Switching Offset Voltage

Vreg Voltage	Measurement Offset Value	Shift Setting Voltage	Select Command
5.2V	1.25V or higher	-1.0V	(24) ₈
5.2V	2.35V or higher	-2.0V	(25) ₈
5.2V	3.45V or higher	-3.0V	(26) ₈
5.2V	4.10V or higher	-3.6V	(27) ₈

Table 6 Measurable Current Values

Vreg Voltage	Current Monitor Amplifier Amplification Ratio	Maximum Measurable Current Value		Minimum Resolution (10bit A/D)
		<u>20 mΩ</u> Sensor Resistor* ¹	Current Coefficient* ²	
5.2V	40x	5.1A (Vcc = 11.0V)	0.101	5.8mA
5.2V	100x	1.9A (Vcc = 11.0V)	0.039	2.3mA
5.2V	200x	1.1A (Vcc = 11.0V)	0.023	1.2mA

Note *1 The maximum measurable current value is dependent on the Vcc voltage. If the Vcc voltage drops the maximum measurable current value also drops.

*2 If the sensor resistor value changes the current coefficient becomes the maximum measurable current value divided by the new sensor resistor value.

Example: If the sensor resistor value = 15 mΩ, Vreg = 5.2 V, and the amplification ratio is 20x ...

Maximum measurable current value = 0.101(current coefficient) ÷ 0.015 [Ω] = 6.73 [A]

(3) Overcurrent Detect Circuit Block

As shown in figure 9, the overcurrent detect circuit block of the M61043FP consists of a comparator, a reference voltage circuit, and a delay circuit.

The detection voltage can be adjusted by trimming, making possible highly accurate voltage detection in conjunction with a sensor resistor. In addition, it is possible to determine when the M61043FP is in overcurrent detect status by monitoring the CIN pin using the microprocessor.

The M61043FP is also equipped with a simplified load detect circuit. Based on the status of the Vin12 pin it is possible to provide protection with a shorter delay time than when using overcurrent detection.

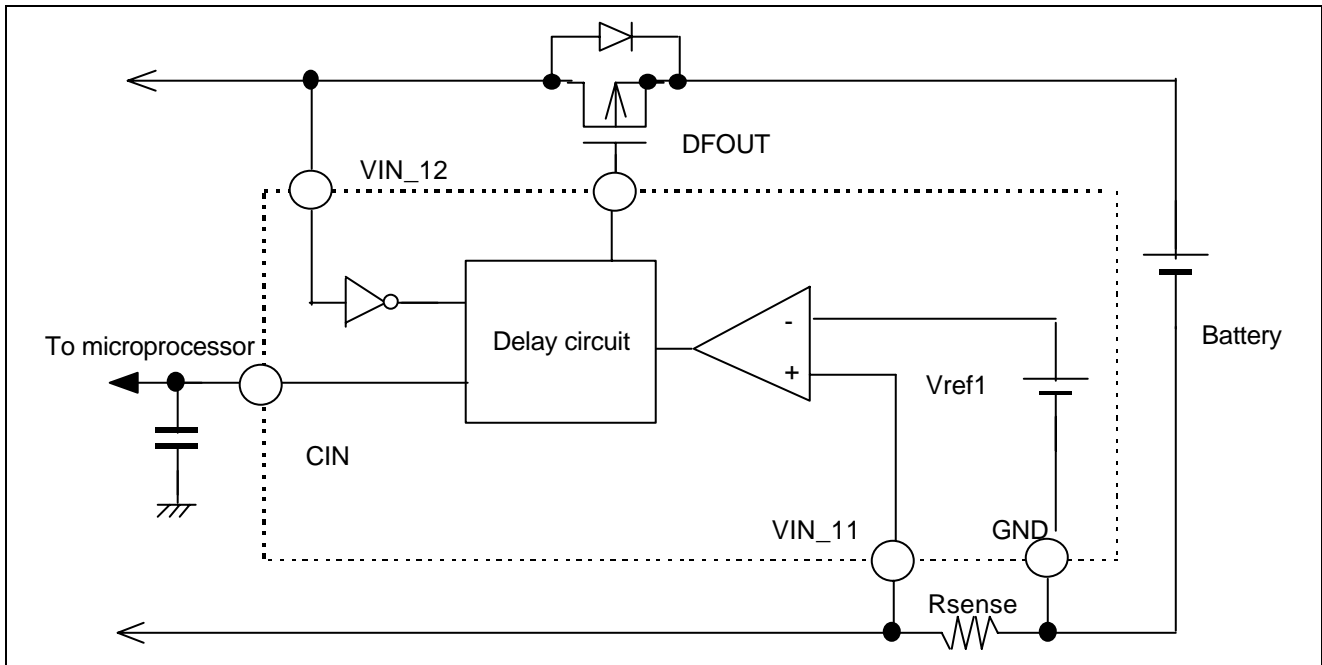

Figure 9 Overcurrent Detect Circuit Block

(4) Series Regulator

The series regulator circuit is shown in figure 10. A Pch MOS transistor is used as the output control transistor. The output voltage is adjusted by the M61043FP internally, so no external devices, such as resistors, are required.

Note : Due to the structure of the control transistor a parasite diode is formed between VCC and Vreg. This means that the M61043FP can be destroyed by reverse current if the Vreg potential exceeds VCC. Consequently, Vreg should be limited to $VCC + 0.3\text{ V}$ or less.

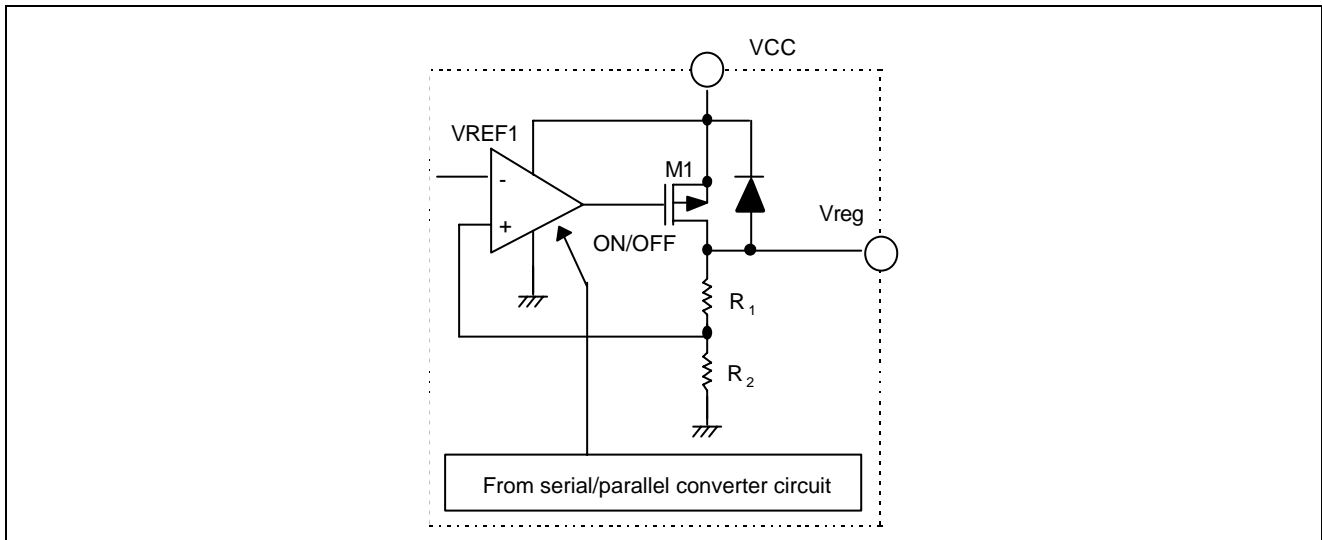

Figure 10 Series Regulator

(5) Reset Circuit Block

As shown in figure 11, the reset circuit block of the M61041FP consists of a converter, a reference voltage circuit, and bleeder resistors.

Output is via the Nch open drain circuit, so an external CR can be connected to specify the cancel delay time.

The reset circuit monitors the Vreg output and prevents microprocessor runaway if the power supply voltage should drop to some sort of malfunction.

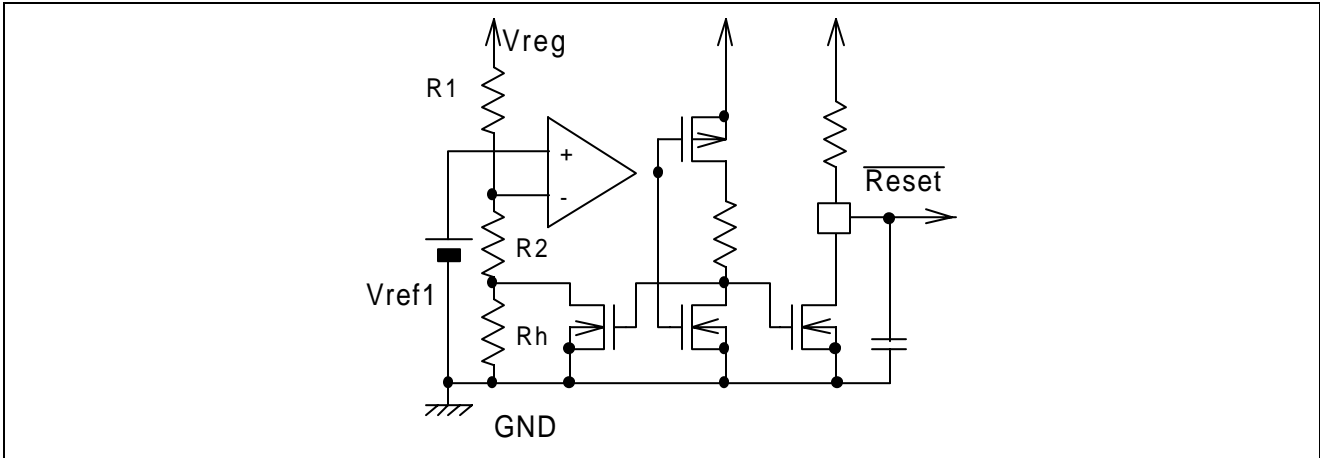

Figure 11 Reset Circuit Block

Digital Data Format

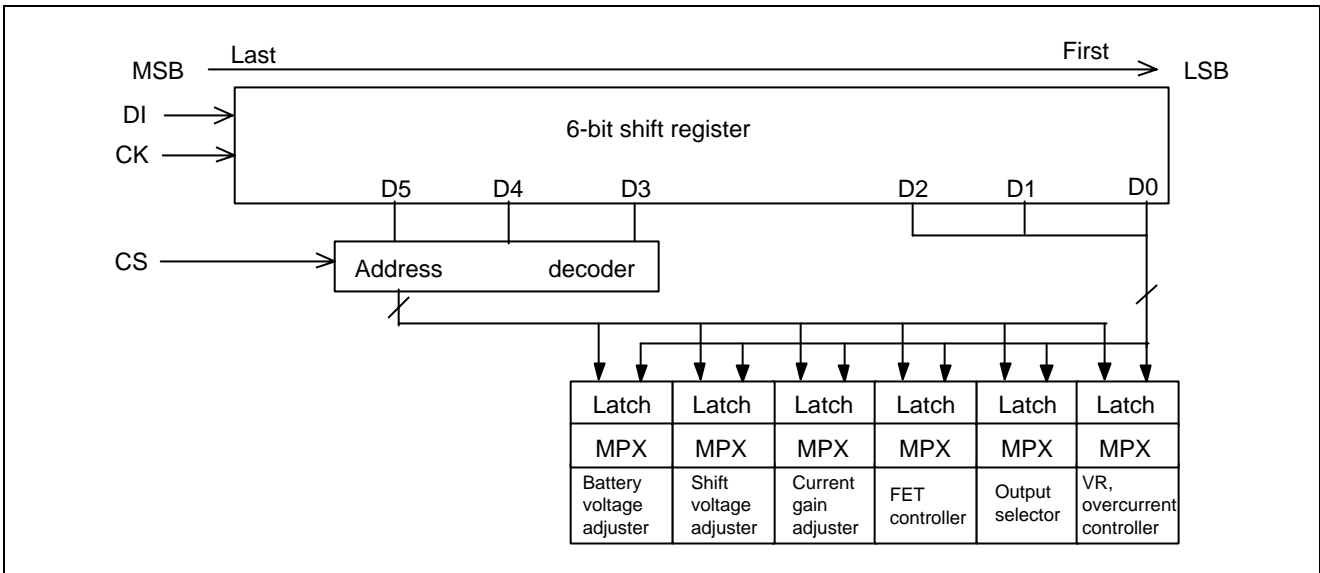

Figure 12 Serial/Parallel Converter Circuit Block Diagram

Data Timing Diagram (Model)

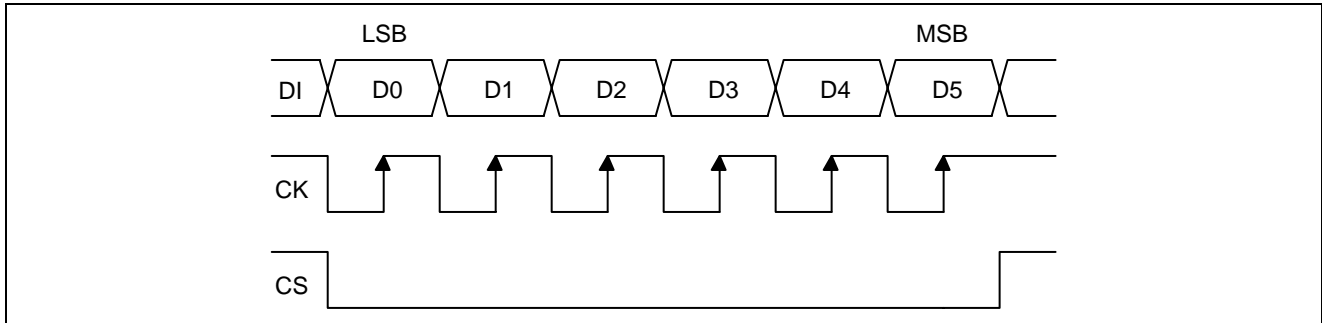

Figure 13 Serial/Parallel Converter Circuit Timing Chart

Data Content

Table 7

Setting Data	Address			Data			Content
	D5	D4	D3	D2	D1	D0	
Reset	0	0	0	—	—	—	
Battery voltage selector	0	0	1	—	—	—	See table 8
Current output shift voltage adjuster	0	1	0	—	—	—	See table 9
Current monitor gain adjuster	0	1	1	—	—	—	See table 10
FET controller	1	0	0	—	—	—	See table 11
Output selector	1	0	1	—	—	—	See table 12
Regulator	1	1	1	—	—	—	See table 13
Overcurrent detection controller							

Data Content

Table 8 Battery Voltage Selector

D5 to D3	D2	D1	D0	Output Voltage	Note
001	0	0	0	0 V (no shift voltage)	Selected after reset
001	0	0	1	V1 voltage	
001	0	1	0	V2 voltage	
001	0	1	1	V3 voltage	
001	1	0	0	0 V (no shift voltage)	
001	1	0	1	V1 offset voltage	
001	1	1	0	V2 offset voltage	
001	1	1	1	V3 offset voltage	

Note : V1 voltage is selected after reset.
 The V0 offset voltage should not be used.

Table 9 Current Output Shift Voltage Adjuster

D5 to D3	D2	D1	D0	Current Output Shift Voltage Value	Note
010	0	0	0	0 V (no shift voltage)	Selected after reset
010	0	0	1	0 V (no shift voltage)	
010	0	1	0	0 V (no shift voltage)	
010	0	1	1	0 V (no shift voltage)	
010	1	0	0	1V	Vreg/25×5
010	1	0	1	2V	Vreg/25×10
010	1	1	0	3V	Vreg/25×15
010	1	1	1	3.6V	Vreg/25×18

Note : No current output shift voltage after reset.

Table 10 Charge/Discharge Current Detector

D5 to D3	D2	D1	D0	Output Gain Switch	Note
011	0	0	0	Amplifier off	Selected after reset
011	0	0	1	40× (current value output)	
011	0	1	0	100× (current value output)	
011	0	1	1	200× (current value output)	
011	1	0	0	Amplifier off	Same as after reset
011	1	0	1	40× (offset output)	
011	1	1	0	100× (offset output)	
011	1	1	1	200× (offset output)	

Note : Amplifier off after reset.

Table 11 FET Controller

D5 to D3	D2	D1	D0	CFOUT	DFOUT	Note
100	0	0	0	High	High	Selected after reset
100	0	0	1	Low	High	
100	0	1	0	High	Low	
100	0	1	1	Low	Low	
100	1	0	0	Don't care	Don't care	
100	1	0	1	Don't care	Don't care	
100	1	1	0	Don't care	Don't care	
100	1	1	1	Don't care	Don't care	

Note : DFOUT and CFOUT pins set to off after reset. (Current control FET is off when output is high level.)

Table 12 Output Selector

D5 to D3	D2	D1	D0	Output Selection	Note
101	0	0	0	Ground output	Selected after reset
101	0	0	1	Battery voltage value output	
101	0	1	0	Charge current value output	
101	0	1	1	Discharge current value output	
101	1	0	0	Don't care	
101	1	0	1	Don't care	
101	1	1	0	Don't care	
101	1	1	1	Don't care	

Note : Ground potential output after reset.

Table 13 Regulator, Overcurrent Detection Controller

D5 to D3	D2	D1	D0	Voltage Regulator Output	Overcurrent Detect Circuit	Note
111	0	0	0	ON	ON	Selected after reset
111	0	0	1	OFF	OFF	Both circuits off
111	0	1	0	ON	CIN pin fixed low	Overcurrent circuit off
111	0	1	1	ON	CIN pin fixed high	Overcurrent circuit off
111	1	0	0	Don't care	Don't care	
111	1	0	1	Don't care	Don't care	
111	1	1	0	Don't care	Don't care	
111	1	1	1	Don't care	Don't care	

Note : Regulator output and overcurrent circuit both on after reset.

Note: A setting of 111001 caused the M61042FP to transition to the power-down mode. However, transition to the power-down mode does not occur when connected to a charger (VIN_12 is high level).

Timing Charts

Charging Sequence

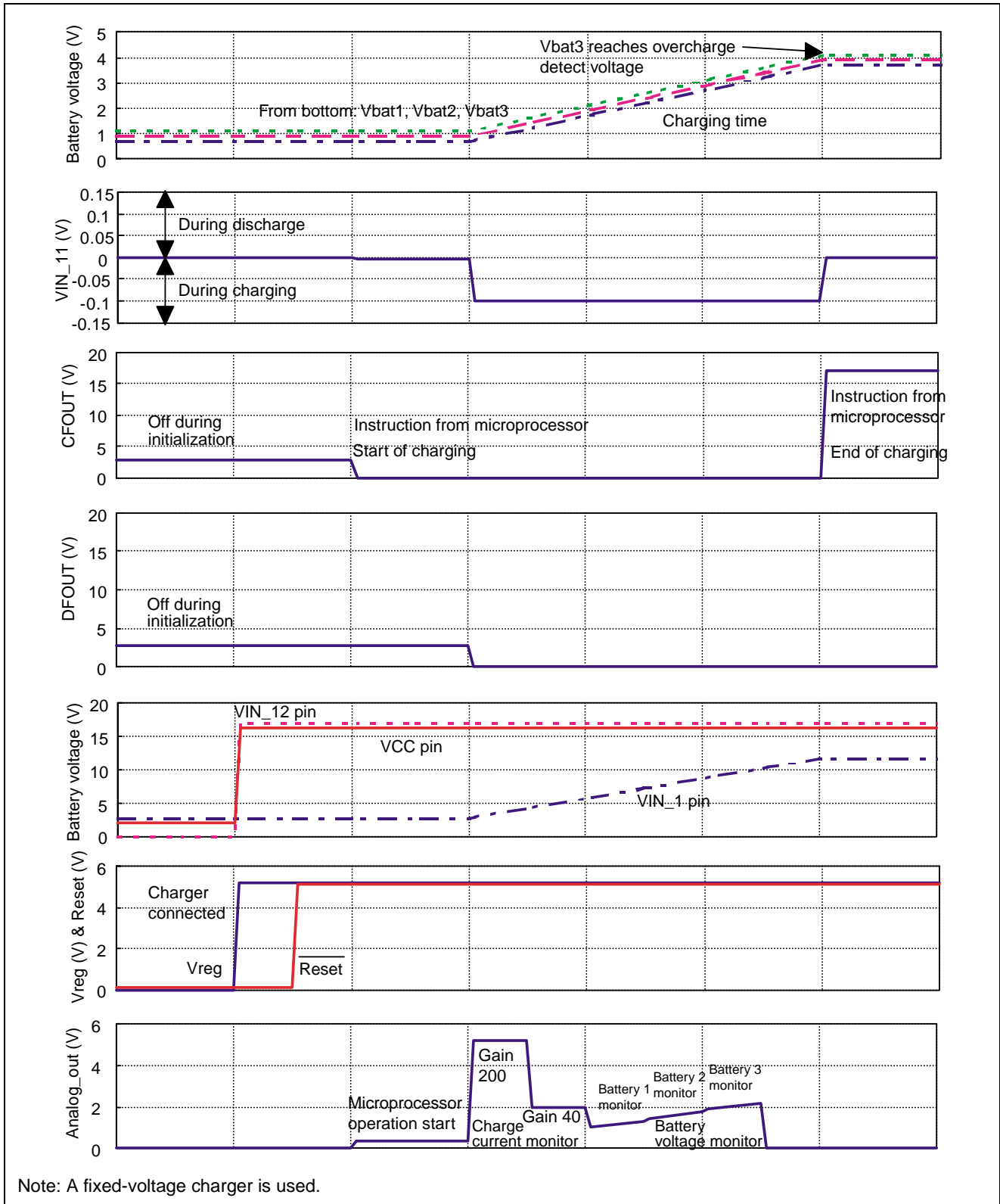

Figure 15 Charging Sequence

Discharge Sequence

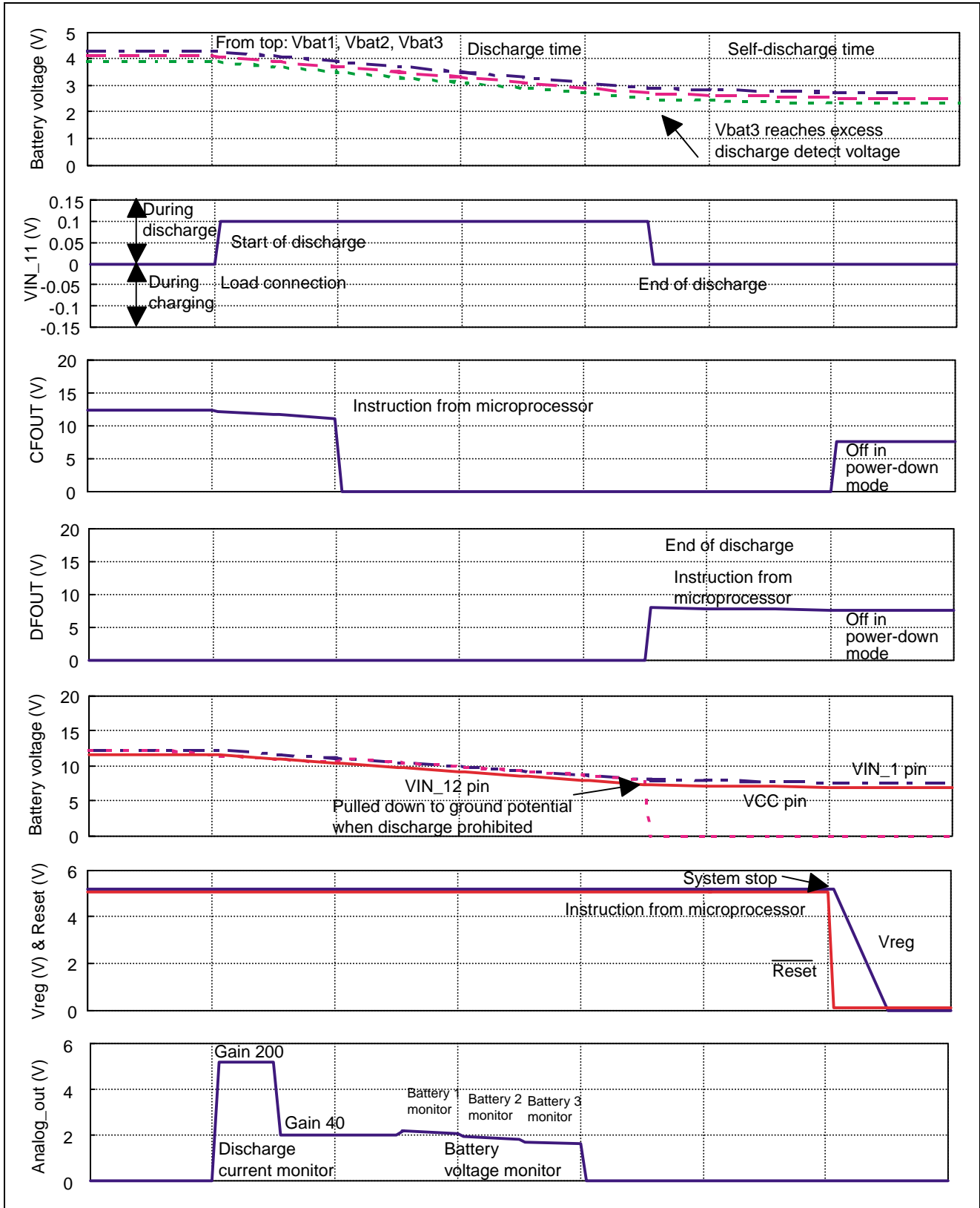

Figure 16 Discharge Sequence

Overcurrent Sequence

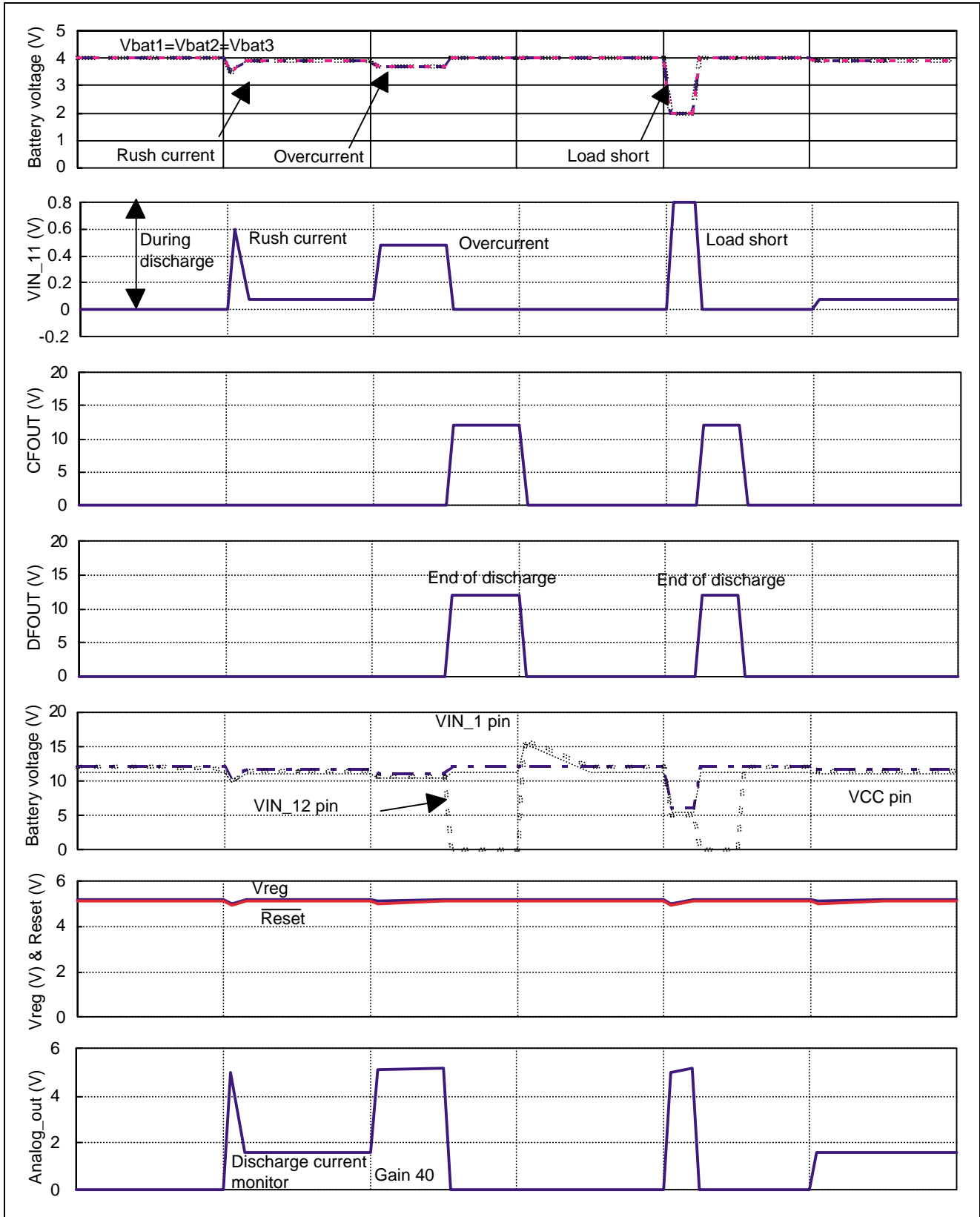
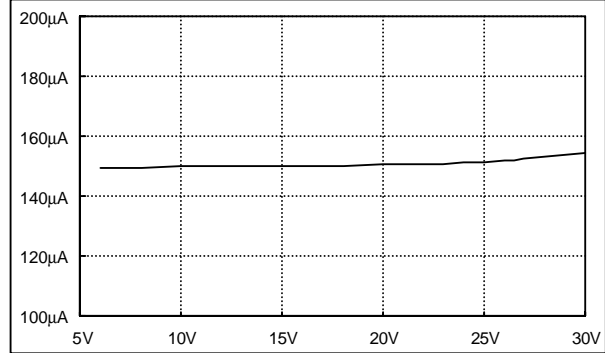

Figure 17 Overcurrent Sequence

Principal Item Characteristics

Overall

Current Consumption (ISUP1)-Power Supply Voltage (VCC) Characteristics
Temp.=25°C



Current Consumption (ISUP1)-Temperature (Ta) Characteristics

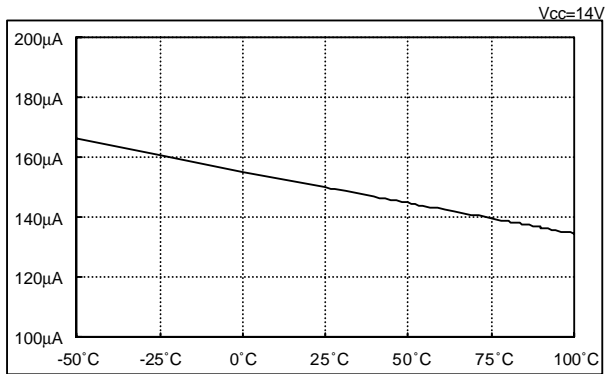

Current Consumption (ISUP2)-Power Supply Voltage (VCC) Characteristics
Temp.=25°C

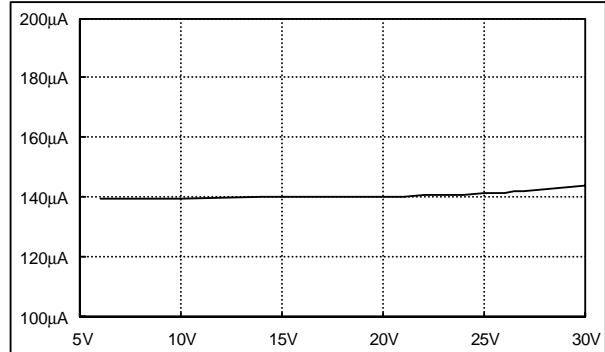

Current Consumption (ISUP3)-Temperature (Ta) Characteristics

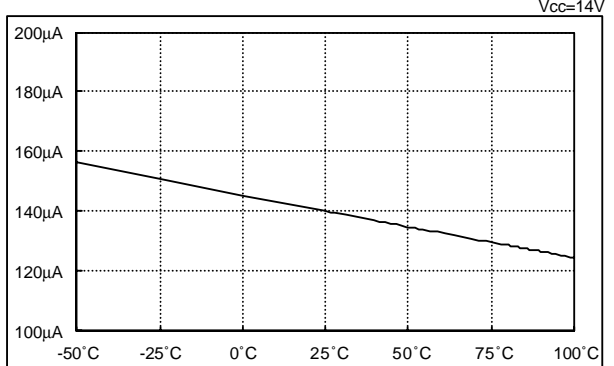

Current Consumption (IPS)-Power Supply Voltage (VCC) Characteristics
Temp.=25°C

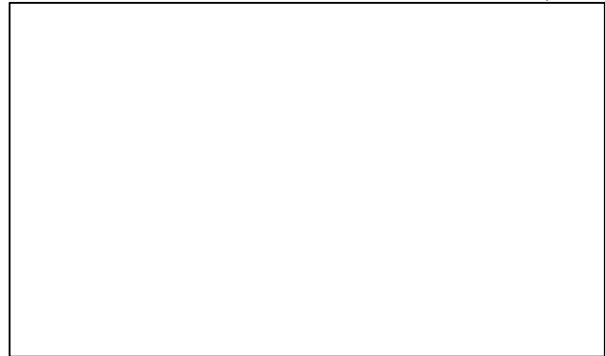

Current Consumption (IPS)-Temperature (Ta) Characteristics



Current Consumption (IPD)-Power Supply Voltage (VCC) Characteristics
Temp.=25°C

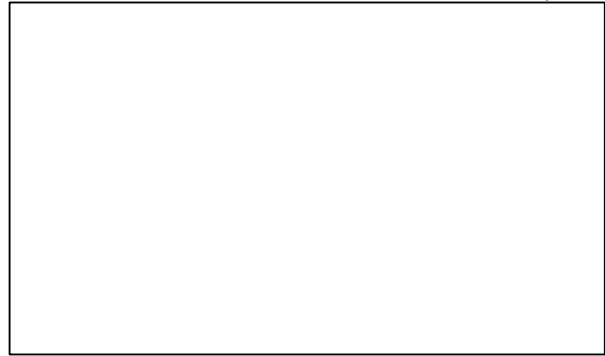

Current Consumption (IPD)-Temperature (Ta) Characteristics

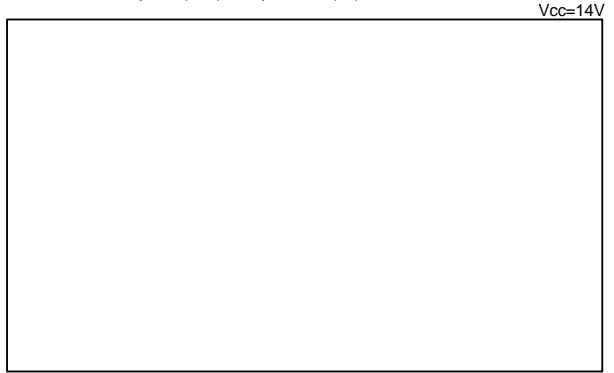

Regulator Block

Regulator Output Voltage (VREG)-Power Supply Voltage (VCC) Characteristics
Temp.=100°C

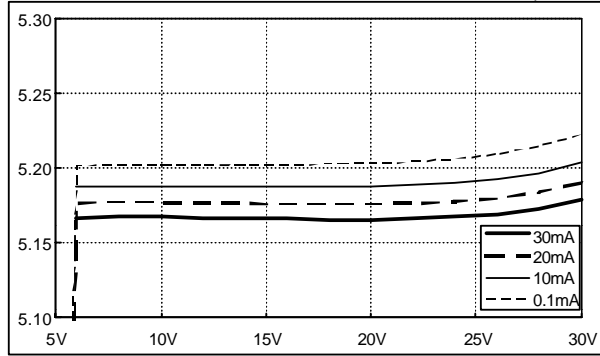

Regulator Output Voltage (VREG)-Temperature (Ta) Characteristics

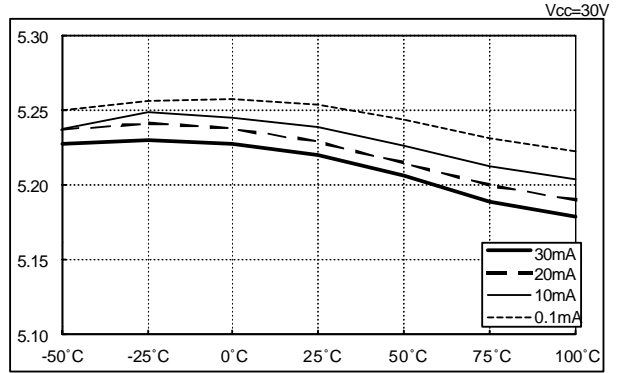

Regulator Output Voltage (VREG)-Power Supply Voltage (VCC) Characteristics
Temp.=25°C

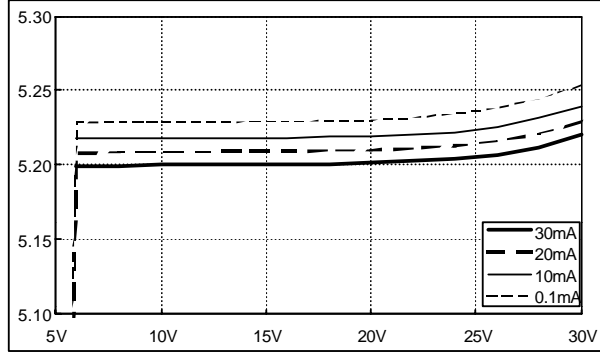

Regulator Output Voltage (VREG)-Temperature (Ta) Characteristics

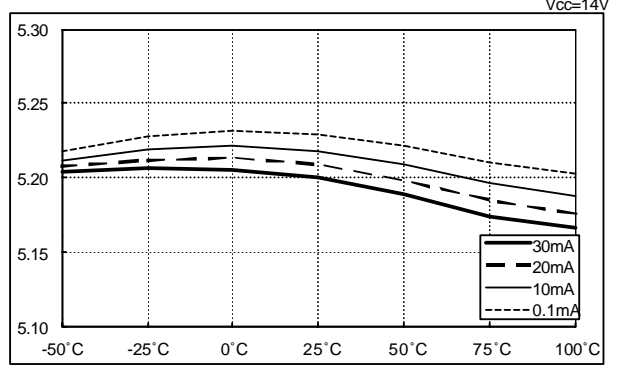

Regulator Output Voltage (VREG)-Power Supply Voltage (VCC) Characteristics
Temp.=25°C

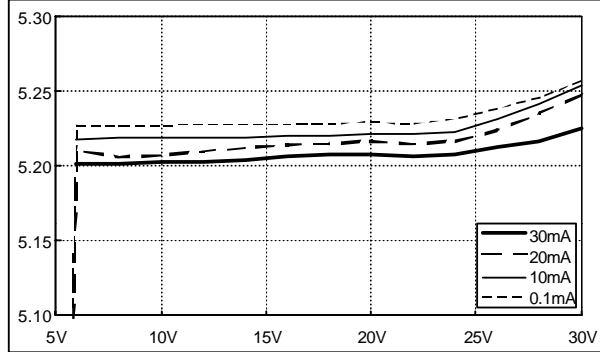

Regulator Output Voltage (VREG)-Temperature (Ta) Characteristics

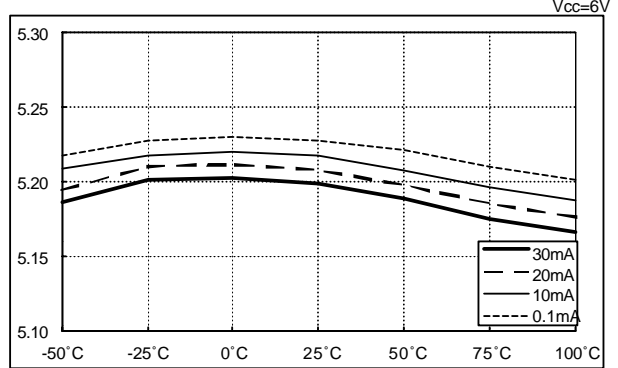

Regulator Output Voltage (VREG)-Output Current (IREG) Characteristics
Temp.=25°C

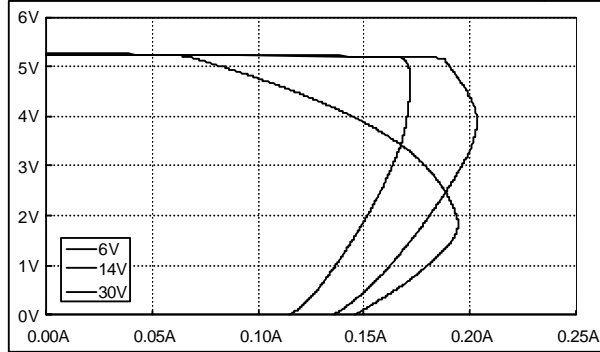

Regulator Output Voltage (VREG)-Output Current (IREG) Characteristics

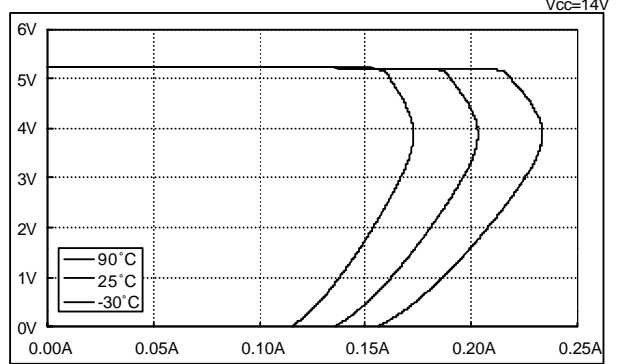

Overcurrent Detect Block

Overcurrent 1 Detect Voltage (VIOV1)-Temperature (Ta) Characteristics

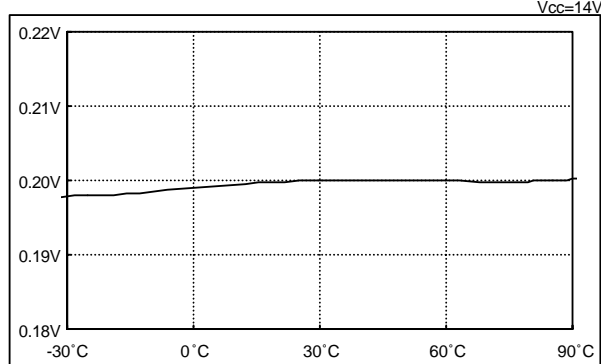

Overcurrent 1 Detect Delay Time (TIOV1)-Temperature (Ta) Characteristics

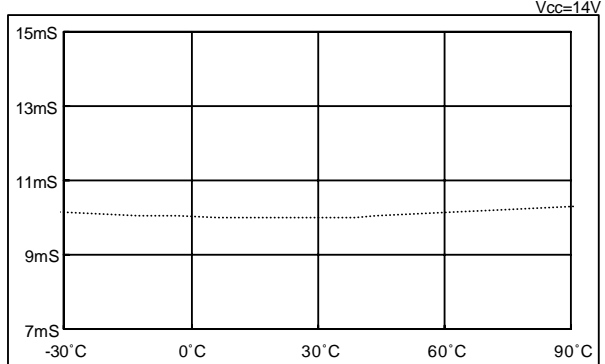

Overcurrent 2 Detect Voltage (VCC/VIOV2)-Temperature (Ta) Characteristics

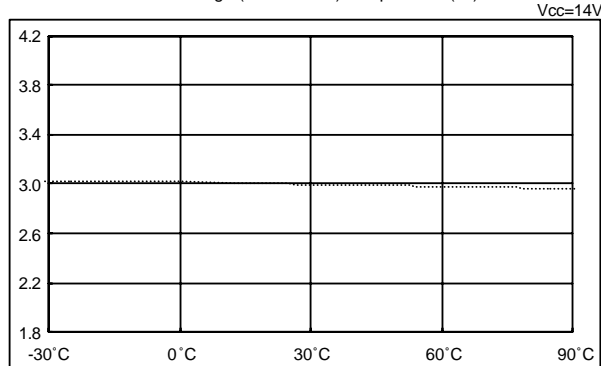

Overcurrent 2 Detect Delay Time (TIOV2)-Temperature (Ta) Characteristics

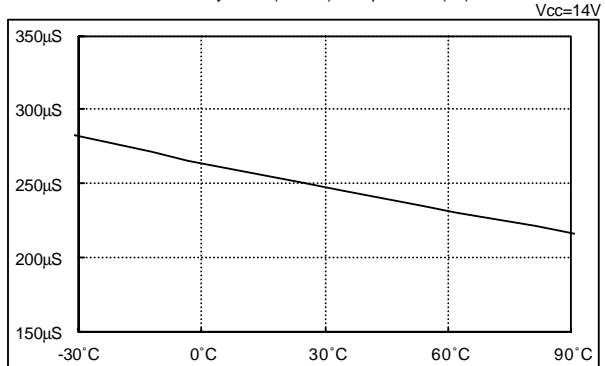

Overcurrent Hold Detect Voltage (VCC-VIOVX)-Temperature (Ta) Characteristics

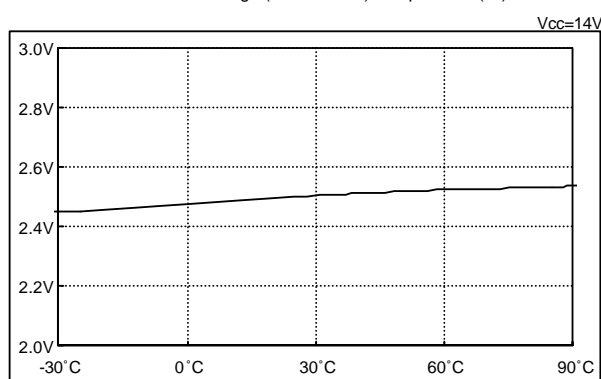

Overcurrent 1 Detect Delay Time (TIOV1)-Capacitance (CICT) Characteristics

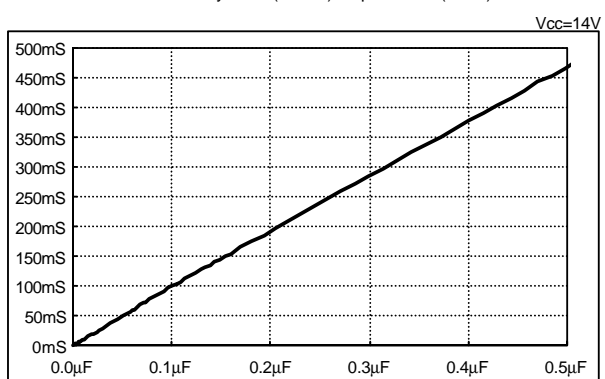

Reset Block

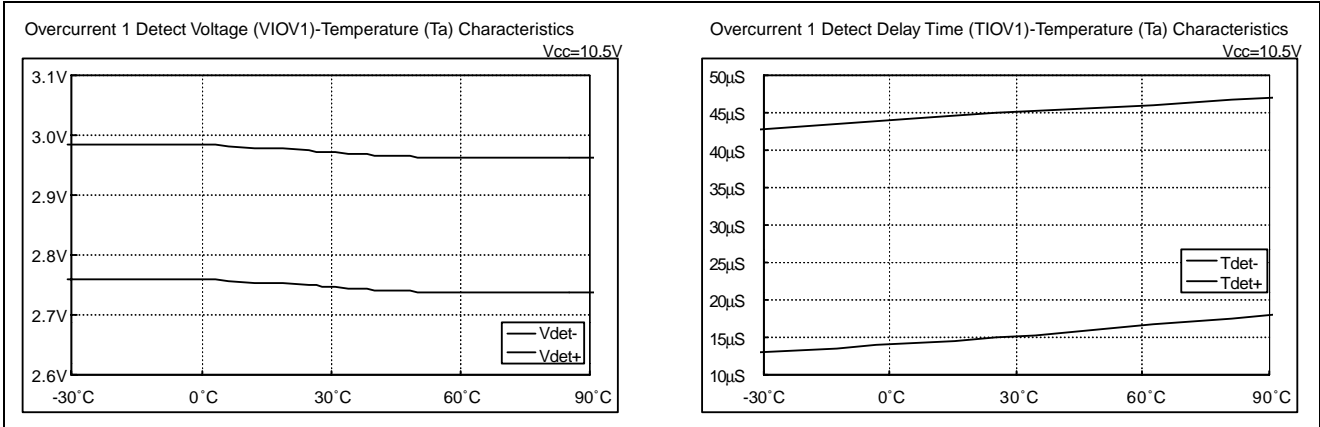

Battery Voltage Detect Block

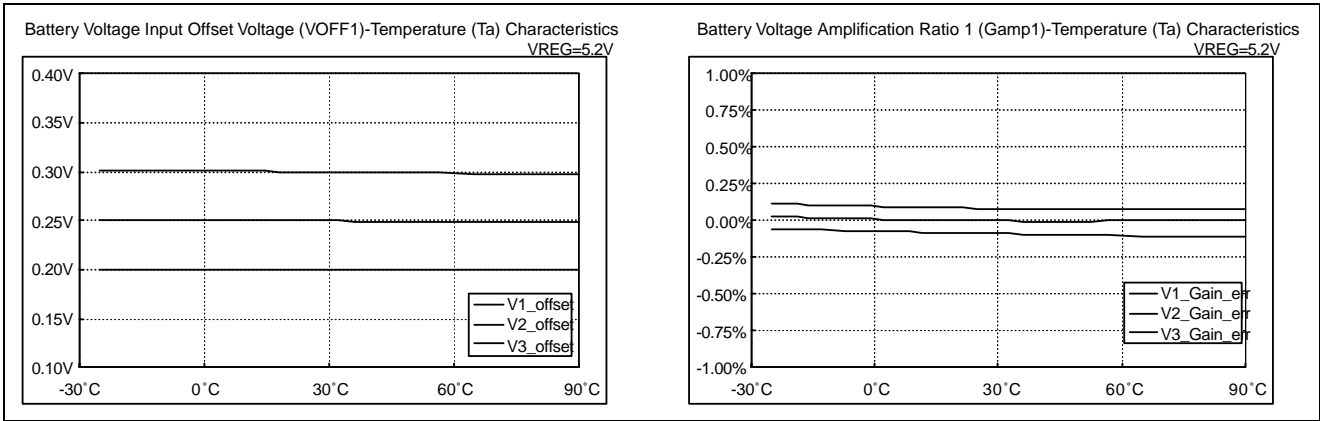

Battery Voltage Detect Block

Battery Voltage Input Offset Voltage (VOFF2)-Temperature (Ta) Characteristics
VREG=5.2V

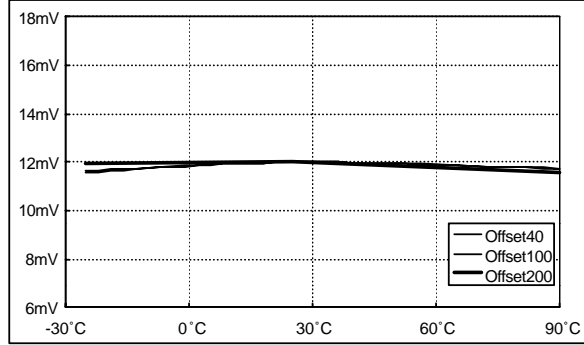

Discharge Current Input Offset Voltage (VOFF2)-Temperature (Ta) Characteristics
VREG=5.2V

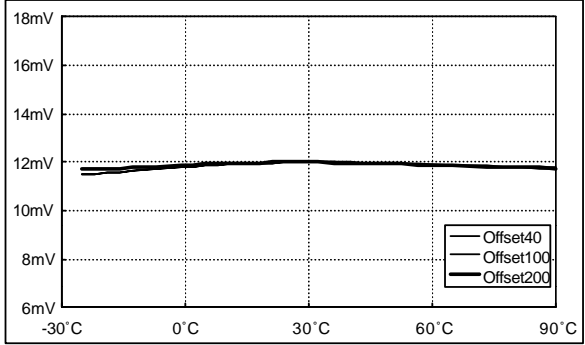

Battery Voltage Amplification Ratio (Gamp2)-Temperature (Ta) Characteristics
VREG=5.2V

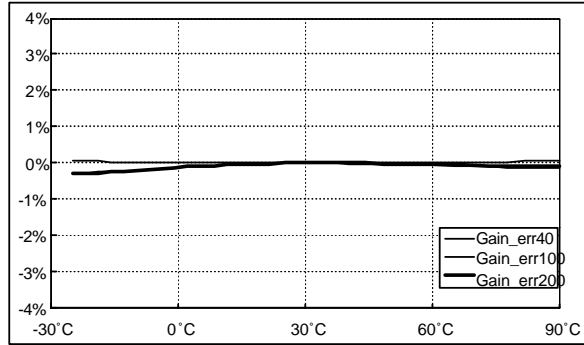

Discharge Current Amplification Ratio (Gamp2)-Temperature (Ta) Characteristics
VREG=5.2V

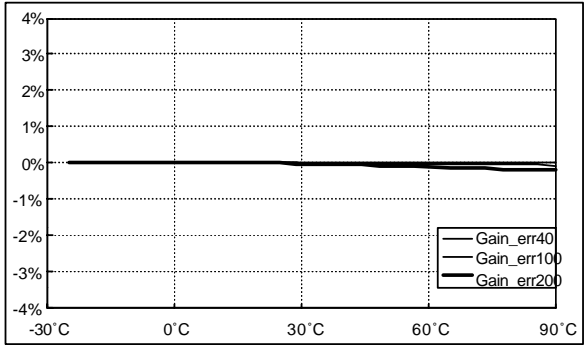

Table 14 External Device Constants

Device	Symbol	Purpose	Recommended Value	Min.	Max.	Notes
Pch MOSFET	DFET	Discharge control	—	—	—	—
Pch MOSFET	CFET	Charge control	—	—	—	—
Resistor	RIN1	ESD countermeasure	10 Ω	—	1k Ω	1) Values differ among RIN2 to RIN3.
Capacitor	CIN1	Power supply fluctuation countermeasure	0.22 μ F	—	1.0 μ F	
Resistor	RIN2	ESD countermeasure	1k Ω	—	1M Ω	—
Capacitor	CIN2	Power supply fluctuation countermeasure	0.22 μ F	—	1.0 μ F	
Resistor	RIN3	ESD countermeasure	1k Ω	—	1M Ω	2) RIN2 and CIN2 should be set to the same value.
Capacitor	CIN3	Power supply fluctuation countermeasure	0.22 μ F	—	1.0 μ F	
Resistor	RIN12	Charger reverse connection countermeasure	10k Ω	300 Ω	100k Ω	3) The upper value for confirmation of overcurrent operation should be adjusted as necessary.
Capacitor	CIN12	Power supply fluctuation countermeasure	0.01 μ F	—	0.1 μ F	
Resistor	RIN11	Power supply fluctuation countermeasure	100 Ω	—	200 Ω	3) The upper value for confirmation of overcurrent operation should be adjusted as necessary.
Capacitor	CIN11	Power supply fluctuation countermeasure	0.1 μ F	—	1.0 μ F	
Capacitor	CVCC	Power supply fluctuation countermeasure	0.22 μ F	—	—	—
Sensor resistor	RSENSE	Charge/discharge current monitoring	20m Ω	—	—	—
Capacitor	CICT	Delay time setting	0.01 μ F	—	0.47 μ F	—
Capacitor	CREG	Output voltage fluctuation countermeasure	4.7 μ F	0.47 μ F	—	—
Resistor	RRST	Delay time setting	47k Ω	10k Ω	10M Ω	5) Adjustment should be performed in conjunction with the microprocessor.
Capacitor	CRST	Delay time setting	0.1 μ F	—	—	
Resistor	RCF	Power supply fluctuation countermeasure	1k Ω	500 Ω	—	3) The upper value for confirmation of overcurrent operation should be adjusted as necessary.
Capacitor	CCF	Power supply fluctuation countermeasure	0.1 μ F	0.047 μ F	—	

Note: When designing applications, due consideration should be given to safety.

Package Dimensions

16P2X

Note : Please contact Renesas Technology Corporation for further details.

RENESAS Technology Corp. Sales Strategic Planning Div. Nippon Bldg., 2-6-2, Ohte-machi, Chiyoda-ku, Tokyo 100-0004, Japan

Keep safety first in your circuit designs!

1. Renesas Technology Corp. puts the maximum effort into making semiconductor products better and more reliable, but there is always the possibility that trouble may occur with them. Trouble with semiconductors may lead to personal injury, fire or property damage.
Remember to give due consideration to safety when making your circuit designs, with appropriate measures such as (i) placement of substitutive, auxiliary circuits, (ii) use of nonflammable material or (iii) prevention against any malfunction or mishap.

Notes regarding these materials

1. These materials are intended as a reference to assist our customers in the selection of the Renesas Technology Corp. product best suited to the customer's application; they do not convey any license under any intellectual property rights, or any other rights, belonging to Renesas Technology Corp. or a third party.
 2. Renesas Technology Corp. assumes no responsibility for any damage, or infringement of any third-party's rights, originating in the use of any product data, diagrams, charts, programs, algorithms, or circuit application examples contained in these materials.
 3. All information contained in these materials, including product data, diagrams, charts, programs and algorithms represents information on products at the time of publication of these materials, and are subject to change by Renesas Technology Corp. without notice due to product improvements or other reasons. It is therefore recommended that customers contact Renesas Technology Corp. or an authorized Renesas Technology Corp. product distributor for the latest product information before purchasing a product listed herein.
The information described here may contain technical inaccuracies or typographical errors.
Renesas Technology Corp. assumes no responsibility for any damage, liability, or other loss rising from these inaccuracies or errors.
Please also pay attention to information published by Renesas Technology Corp. by various means, including the Renesas Technology Corp. Semiconductor home page (<http://www.renesas.com>).
 4. When using any or all of the information contained in these materials, including product data, diagrams, charts, programs, and algorithms, please be sure to evaluate all information as a total system before making a final decision on the applicability of the information and products. Renesas Technology Corp. assumes no responsibility for any damage, liability or other loss resulting from the information contained herein.
 5. Renesas Technology Corp. semiconductors are not designed or manufactured for use in a device or system that is used under circumstances in which human life is potentially at stake. Please contact Renesas Technology Corp. or an authorized Renesas Technology Corp. product distributor when considering the use of a product contained herein for any specific purposes, such as apparatus or systems for transportation, vehicular, medical, aerospace, nuclear, or undersea repeater use.
 6. The prior written approval of Renesas Technology Corp. is necessary to reprint or reproduce in whole or in part these materials.
 7. If these products or technologies are subject to the Japanese export control restrictions, they must be exported under a license from the Japanese government and cannot be imported into a country other than the approved destination.
Any diversion or reexport contrary to the export control laws and regulations of Japan and/or the country of destination is prohibited.
 8. Please contact Renesas Technology Corp. for further details on these materials or the products contained therein.
-



RENESAS SALES OFFICES

<http://www.renesas.com>

Renesas Technology America, Inc.
450 Holger Way, San Jose, CA 95134-1368, U.S.A
Tel: <1> (408) 382-7500 Fax: <1> (408) 382-7501

Renesas Technology Europe Limited.
Dukes Meadow, Millboard Road, Bourne End, Buckinghamshire, SL8 5FH, United Kingdom
Tel: <44> (1628) 585 100, Fax: <44> (1628) 585 900

Renesas Technology Europe GmbH
Dornacher Str. 3, D-85622 Feldkirchen, Germany
Tel: <49> (89) 380 70 0, Fax: <49> (89) 929 30 11

Renesas Technology Hong Kong Ltd.
7/F., North Tower, World Finance Centre, Harbour City, Canton Road, Hong Kong
Tel: <852> 2265-6688, Fax: <852> 2375-6836

Renesas Technology Taiwan Co., Ltd.
FL 10, #99, Fu-Hsing N. Rd., Taipei, Taiwan
Tel: <886> (2) 2715-2888, Fax: <886> (2) 2713-2999

Renesas Technology (Shanghai) Co., Ltd.
26/F., Ruijin Building, No.205 Maoming Road (S), Shanghai 200020, China
Tel: <86> (21) 6472-1001, Fax: <86> (21) 6415-2952

Renesas Technology Singapore Pte. Ltd.
1, Harbour Front Avenue, #06-10, Keppel Bay Tower, Singapore 098632
Tel: <65> 6213-0200, Fax: <65> 6278-8001