

NOTES: UNLESS OTHERWISE SPECIFIED  
 1. INTERFACE COMPLIANT TO SMPTE 304 SPECIFICATION.

2. MATERIAL SPECIFICATIONS:  
 CONTACTS: COPPER ALLOY  
 CRIMP SLEEVE: PHOS. BRONZE  
 O-RING: SILICONE RUBBER  
 SHIELD GROUND: 303 STAINLESS STEEL PER ASTM A582

3. FINISH SPECIFICATIONS:  
 STAINLESS STEEL PARTS: PASSIVATE  
 CONTACTS: .000100 MIN GOLD PER ASTM B488 OVER  
 .000080 MIN NICKEL PER AMS-QQN-290 (RoHS)  
 CRIMP SLEEVE: .000100 MIN NICKEL PER AMS-QQ-N-290 OVER  
 COPPER FLASH PER ASTM B734 (RoHS)

4. REPLACEMENT KIT FOR ASSEMBLY: 7763-3-3

5. CABLE ASSEMBLY PROCEDURE CAP-E05

REV	DESCRIPTION	BY DATE	APPD
A	RELEASED PER ER22697	PSM 04/08/09	WPM

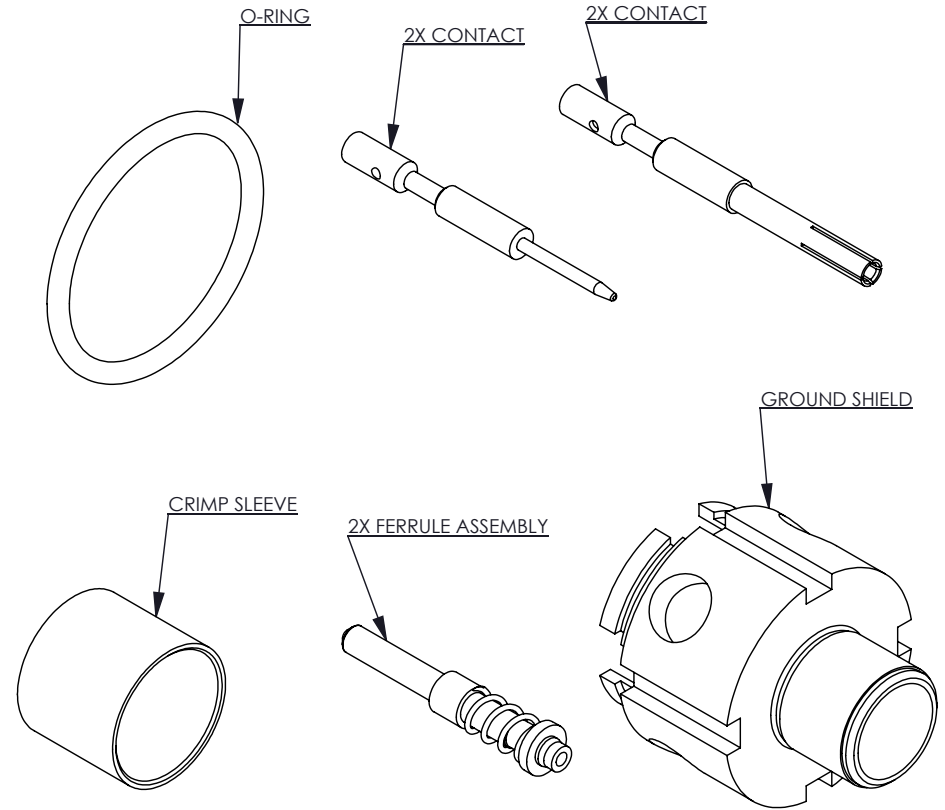

CATALOG P/N: 7760-000-00702Z

PER ASME Y14.5M-1994 UNLESS OTHERWISE SPECIFIED: DIMENSIONS ARE IN INCHES [MM] TOLERANCES: DECIMAL: .XX [X.X] ± .01 [0.3] .XXX [X.XX] ± .005 [0.13] .XXXX [X.XXX] ± .XXXX ANGLES: ± 2° SCALE: 2:1				 by WINCHESTER <small>ELECTRONICS</small> Winchester Electronics Corporation 62 Barnes Industrial Road North Wallingford, Connecticut 06492	
CUSTOMER SALES DRAWING			THIRD ANGLE		
DRAWN DATE PSM 03/30/09		APPROVED DATE WPM 08/17/09		KIT - CONTACT	
APPROVED DATE RL 08/17/09		APPROVED DATE JF 08/17/09		<b>A</b> SD7760-000-00702Z SHT OF REV 1 1 A	