

## Features

- Core
  - ARM® Cortex®-M4 with a 2Kbytes cache running at up to 120 MHz
  - Memory Protection Unit (MPU)
  - DSP Instruction Set
  - Thumb®-2 instruction set
- Pin-to-pin compatible with SAM3N, SAM3S products (64- and 100- pin versions) and SAM7S legacy products (64-pin version)
- Memories
  - Up to 2048 Kbytes embedded Flash with optional dual bank and cache memory
  - Up to 160 Kbytes embedded SRAM
  - 16 Kbytes ROM with embedded boot loader routines (UART, USB) and IAP routines
  - 8-bit Static Memory Controller (SMC): SRAM, PSRAM, NOR and NAND Flash support
- System
  - Embedded voltage regulator for single supply operation
  - Power-on-Reset (POR), Brown-out Detector (BOD) and Watchdog for safe operation
  - Quartz or ceramic resonator oscillators: 3 to 20 MHz main power with Failure Detection and optional low-power 32.768 kHz for RTC or device clock
  - RTC with Gregorian and Persian Calendar mode, waveform generation in low-power modes
  - RTC clock calibration circuitry for 32.768 kHz crystal frequency compensation
  - High precision 8/12 MHz factory trimmed internal RC oscillator with 4 MHz default frequency for device startup. In-application trimming access for frequency adjustment
  - Slow Clock Internal RC oscillator as permanent low-power mode device clock
  - Two PLLs up to 240 MHz for device clock and for USB
  - Temperature Sensor
  - Up to 22 Peripheral DMA (PDC) Channels
- Low Power Modes
  - Sleep and Backup Modes, down to 1 µA in Backup Mode
  - Ultra low-power RTC
- Peripherals
  - USB 2.0 Device: 12 Mbps, 2668 byte FIFO, up to 8 bidirectional Endpoints. On-Chip Transceiver
  - Up to 2 USARTs with ISO7816, IrDA®, RS-485, SPI, Manchester and Modem Mode
  - Two 2-wire UARTs
  - Up to 2 Two Wire Interface (I2C compatible), 1 SPI, 1 Serial Synchronous Controller (I2S), 1 High Speed Multimedia Card Interface (SDIO/SD Card/MMC)
  - 2 Three-Channel 16-bit Timer/Counter with capture, waveform, compare and PWM mode. Quadrature Decoder Logic and 2-bit Gray Up/Down Counter for Stepper Motor
  - 4-channel 16-bit PWM with Complementary Output, Fault Input, 12-bit Dead Time Generator Counter for Motor Control
  - 32-bit Real-time Timer and RTC with calendar and alarm features
  - Up to 16-channel, 1Msps ADC with differential input mode and programmable gain stage and auto calibration
  - One 2-channel 12-bit 1Msps DAC
  - One Analog Comparator with flexible input selection, Selectable input hysteresis
  - 32-bit Cyclic Redundancy Check Calculation Unit (CRCCU)
  - Write Protected Registers
- I/O
  - Up to 79 I/O lines with external interrupt capability (edge or level sensitivity), debouncing, glitch filtering and on-die Series Resistor Termination
  - Three 32-bit Parallel Input/Output Controllers, Peripheral DMA assisted Parallel Capture Mode
- Packages
  - 100-lead LQFP, 14 x 14 mm, pitch 0.5 mm/ 100-ball TFBGA, 9 x 9 mm, pitch 0.8 mm/ 100-ball VFBGA, 7 x 7 mm, pitch 0.65 mm
  - 64-lead LQFP, 10 x 10 mm, pitch 0.5 mm/ 64-pad QFN 9x9 mm, pitch 0.5 mm



## AT91SAM ARM-based Flash MCU

## SAM4S Series

## Preliminary

## Summary

**NOTE:** This is a summary document. The complete document is currently not available. For more information, please contact your local Atmel sales office.

11100BS-ATARM-31-Jul-12





## 1. Description

The Atmel SAM4S series is a member of a family of Flash microcontrollers based on the high performance 32-bit ARM Cortex-M4 RISC processor. It operates at a maximum speed of 120 MHz and features up to 2048 Kbytes of Flash, with optional dual bank implementation and cache memory, and up to 160 Kbytes of SRAM. The peripheral set includes a Full Speed USB Device port with embedded transceiver, a High Speed MCI for SDIO/SD/MMC, an External Bus Interface featuring a Static Memory Controller providing connection to SRAM, PSRAM, NOR Flash, LCD Module and NAND Flash, 2x USARTs, 2x UARTs, 2x TWIs, 3x SPI, an I2S, as well as 1 PWM timer, 2x three channel general-purpose 16-bit timers (with stepper motor and quadrature decoder logic support), an RTC, a 12-bit ADC, a 12-bit DAC and an analog comparator.

The SAM4S series is ready for capacitive touch thanks to the QTouch<sup>®</sup> library, offering an easy way to implement buttons, wheels and sliders.

The SAM4S device is a medium range general purpose microcontroller with the best ratio in terms of reduced power consumption, processing power and peripheral set. This enables the SAM4S to sustain a wide range of applications including consumer, industrial control, and PC peripherals.

It operates from 1.62V to 3.6V.

The SAM4S series is pin-to-pin compatible with the SAM3N, SAM3S series (64- and 100-pin versions) and SAM7S legacy series (64-pin versions).

## 1.1 Configuration Summary

The SAM4S series devices differ in memory size, package and features. [Table 1-1](#) summarizes the configurations of the device family.

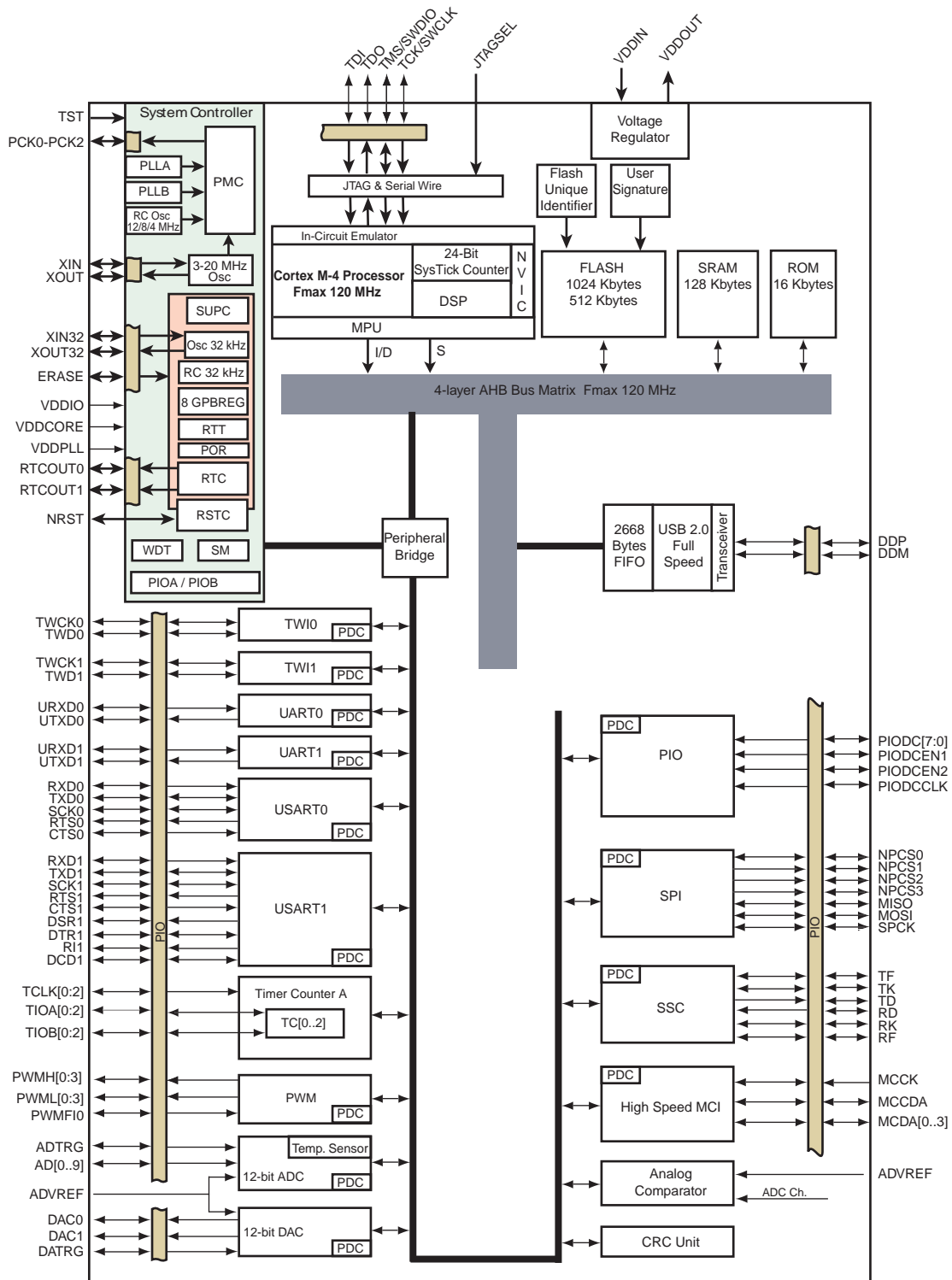
**Table 1-1.** Configuration Summary

Feature	SAM4SD32C	SAM4SD32B	SAM4SD16C	SAM4SD16B	SAM4SA16C	SAM4SA16B	SAM4S16C	SAM4S16B	SAM4S8C	SAM4S8B
<b>Flash</b>	2 x 1024 Kbytes	2 x 1024 Kbytes	2 x 512 Kbytes	2 x 512 Kbytes	1024 Kbytes	1024 Kbytes	1024 Kbytes	1024 Kbytes	512 Kbytes	512 Kbytes
<b>SRAM</b>	160 Kbytes	160 Kbytes	160 Kbytes	160 Kbytes	160 Kbytes	160 Kbytes	128 Kbytes	128 Kbytes	128 Kbytes	128 Kbytes
<b>HCACHE</b>	2Kbytes	2Kbytes	2Kbytes	2Kbytes	2Kbytes	2Kbytes	-	-	-	-
<b>Package</b>	LQFP 100 TFBGA 100 VFBGA 100	LQFP 64 QFN 64	LQFP 100 TFBGA 100 VFBGA 100	LQFP 64 QFN 64	LQFP 100 TFBGA 100 VFBGA 100	LQFP 64 QFN 64	LQFP 100 TFBGA 100 VFBGA 100	LQFP 64 LFBGA 64	LQFP 100 TFBGA 100 VFBGA 100	LQFP 64 QFN 64
<b>Number of PIOs</b>	79	47	79	47	79	47	79	47	79	47
<b>External Bus Interface</b>	8-bit data, 4chip selects, 24-bit address	-	8-bit data, 4chip selects, 24-bit address	-	8-bit data, 4chip selects, 24-bit address	-	8-bit data, 4chip selects, 24-bit address	-	8-bit data, 4chip selects, 24-bit address	-
<b>Central DMA</b>	6	4	6	4	6	4	6	4	6	6
<b>12-bit ADC</b>	16 ch. <sup>(1)</sup>	11 ch. <sup>(1)</sup>	16 ch. <sup>(1)</sup>	11 ch. <sup>(1)</sup>	16 ch. <sup>(1)</sup>	11 ch. <sup>(1)</sup>	16 ch. <sup>(1)</sup>	11 ch. <sup>(1)</sup>	16 ch. <sup>(1)</sup>	11 ch. <sup>(1)</sup>
<b>12-bit DAC</b>	2 ch.	2 ch.	2 ch.	2 ch.	2 ch.	2 ch.	2 ch.	2 ch.	2 ch.	2 ch.
<b>Timer Counter Channels</b>	6	3	6	3	6	3	6	3	6	3
<b>PDC Channels</b>	22	22	22	22	22	22	22	22	22	22
<b>USART/UART</b>	2/2 <sup>(2)</sup>	2/2 <sup>(2)</sup>	2/2 <sup>(2)</sup>	2/2 <sup>(2)</sup>	2/2 <sup>(2)</sup>	2/2 <sup>(2)</sup>	2/2 <sup>(2)</sup>	2/2 <sup>(2)</sup>	2/2 <sup>(2)</sup>	2/2 <sup>(2)</sup>
<b>HSMCI</b>	1 port 4 bits	1 port 4 bits	1 port 4 bits	1 port 4 bits	1 port 4 bits	1 port 4 bits	1 port 4 bits	1 port 4 bits	1 port 4 bits	1 port 4 bits

- Notes: 1. One channel is reserved for internal temperature sensor.  
2. Full Modem support on USART1.



Figure 2-2. SAM4S16/S8 Series 64-pin version Block Diagram







### 3. Signal Description

Table 3-1 gives details on signal names classified by peripheral.

Table 3-1. Signal Description List

Signal Name	Function	Type	Active Level	Voltage reference	Comments
<b>Power Supplies</b>					
VDDIO	Peripherals I/O Lines and USB transceiver Power Supply	Power			1.62V to 3.6V
VDDIN	Voltage Regulator Input, ADC, DAC and Analog Comparator Power Supply	Power			1.62V to 3.6V <sup>(4)</sup>
VDDOUT	Voltage Regulator Output	Power			1.2V Output
VDDPLL	Oscillator and PLL Power Supply	Power			1.08 V to 1.32V
VDDCORE	Power the core, the embedded memories and the peripherals	Power			1.08V to 1.32V
GND	Ground	Ground			
<b>Clocks, Oscillators and PLLs</b>					
XIN	Main Oscillator Input	Input		VDDIO	Reset State: - PIO Input - Internal Pull-up disabled - Schmitt Trigger enabled <sup>(1)</sup>
XOUT	Main Oscillator Output	Output			
XIN32	Slow Clock Oscillator Input	Input			
XOUT32	Slow Clock Oscillator Output	Output			
PCK0 - PCK2	Programmable Clock Output	Output			Reset State: - PIO Input - Internal Pull-up enabled - Schmitt Trigger enabled <sup>(1)</sup>
<b>Real Time Clock</b>					
RTCOUT0	Programmable RTC waveform output	Output		VDDIO	Reset State: - PIO Input - Internal Pull-up disabled - Schmitt Trigger enabled <sup>(1)</sup>
RTCOUT1	Programmable RTC waveform output	Output			
<b>Serial Wire/JTAG Debug Port - SWJ-DP</b>					
TCK/SWCLK	Test Clock/Serial Wire Clock	Input		VDDIO	Reset State: - SWJ-DP Mode - Internal pull-up disabled <sup>(5)</sup> - Schmitt Trigger enabled <sup>(1)</sup>
TDI	Test Data In	Input			
TDO/TRACESWO	Test Data Out / Trace Asynchronous Data Out	Output			
TMS/SWDIO	Test Mode Select /Serial Wire Input/Output	Input / I/O			
JTAGSEL	JTAG Selection	Input	High		Permanent Internal pull-down



**Table 3-1.** Signal Description List (Continued)

Signal Name	Function	Type	Active Level	Voltage reference	Comments
<b>Flash Memory</b>					
ERASE	Flash and NVM Configuration Bits Erase Command	Input	High	VDDIO	Reset State: - Erase Input - Internal pull-down enabled - Schmitt Trigger enabled <sup>(1)</sup>
<b>Reset/Test</b>					
NRST	Synchronous Microcontroller Reset	I/O	Low	VDDIO	Permanent Internal pull-up
TST	Test Select	Input			Permanent Internal pull-down
<b>Universal Asynchronous Receiver Transceiver - UARTx</b>					
URXDx	UART Receive Data	Input			
UTXDx	UART Transmit Data	Output			
<b>PIO Controller - PIOA - PIOB - PIOC</b>					
PA0 - PA31	Parallel IO Controller A	I/O		VDDIO	Reset State: - PIO or System IOs <sup>(2)</sup> - Internal pull-up enabled - Schmitt Trigger enabled <sup>(1)</sup>
PB0 - PB14	Parallel IO Controller B	I/O			
PC0 - PC31	Parallel IO Controller C	I/O			
<b>PIO Controller - Parallel Capture Mode</b>					
PIODC0-PIODC7	Parallel Capture Mode Data	Input		VDDIO	
PIODCCLK	Parallel Capture Mode Clock	Input			
PIODCEN1-2	Parallel Capture Mode Enable	Input			
<b>External Bus Interface</b>					
D0 - D7	Data Bus	I/O			
A0 - A23	Address Bus	Output			
NWAIT	External Wait Signal	Input	Low		
<b>Static Memory Controller - SMC</b>					
NCS0 - NCS3	Chip Select Lines	Output	Low		
NRD	Read Signal	Output	Low		
NWE	Write Enable	Output	Low		
<b>NAND Flash Logic</b>					
NANDOE	NAND Flash Output Enable	Output	Low		
NANDWE	NAND Flash Write Enable	Output	Low		
<b>High Speed Multimedia Card Interface - HSMCI</b>					
MCCK	Multimedia Card Clock	I/O			
MCCDA	Multimedia Card Slot A Command	I/O			
MCDA0 - MCDA3	Multimedia Card Slot A Data	I/O			

**Table 3-1. Signal Description List (Continued)**

Signal Name	Function	Type	Active Level	Voltage reference	Comments
<b>Universal Synchronous Asynchronous Receiver Transmitter USARTx</b>					
SCKx	USARTx Serial Clock	I/O			
TXDx	USARTx Transmit Data	I/O			
RXDx	USARTx Receive Data	Input			
RTSx	USARTx Request To Send	Output			
CTSx	USARTx Clear To Send	Input			
DTR1	USART1 Data Terminal Ready	I/O			
DSR1	USART1 Data Set Ready	Input			
DCD1	USART1 Data Carrier Detect	Output			
RI1	USART1 Ring Indicator	Input			
<b>Synchronous Serial Controller - SSC</b>					
TD	SSC Transmit Data	Output			
RD	SSC Receive Data	Input			
TK	SSC Transmit Clock	I/O			
RK	SSC Receive Clock	I/O			
TF	SSC Transmit Frame Sync	I/O			
RF	SSC Receive Frame Sync	I/O			
<b>Timer/Counter - TC</b>					
TCLKx	TC Channel x External Clock Input	Input			
TIOAx	TC Channel x I/O Line A	I/O			
TIOBx	TC Channel x I/O Line B	I/O			
<b>Pulse Width Modulation Controller- PWMC</b>					
PWMHx	PWM Waveform Output High for channel x	Output			
PWMLx	PWM Waveform Output Low for channel x	Output			The only output in complementary mode when dead time insertion is enabled.
PWMFIO	<b>PWM Fault Input</b>	Input			
<b>Serial Peripheral Interface - SPI</b>					
MISO	Master In Slave Out	I/O			
MOSI	Master Out Slave In	I/O			
SPCK	SPI Serial Clock	I/O			
SPI_NPCS0	SPI Peripheral Chip Select 0	I/O	Low		
SPI_NPCS1 - SPI_NPCS3	SPI Peripheral Chip Select	Output	Low		

**Table 3-1.** Signal Description List (Continued)

Signal Name	Function	Type	Active Level	Voltage reference	Comments
<b>Two-Wire Interface- TWI</b>					
TWDx	TWlX Two-wire Serial Data	I/O			
TWCKx	TWlX Two-wire Serial Clock	I/O			
<b>Analog</b>					
ADVREF	ADC, DAC and Analog Comparator Reference	Analog			
<b>12-bit Analog-to-Digital Converter - ADC</b>					
AD0-AD14	Analog Inputs	Analog, Digital			
ADTRG	ADC Trigger	Input		VDDIO	
<b>12-bit Digital-to-Analog Converter - DAC</b>					
DAC0 - DAC1	Analog output	Analog, Digital			
DACTRG	DAC Trigger	Input		VDDIO	
<b>Fast Flash Programming Interface - FFPI</b>					
PGMEN0-PGMEN2	Programming Enabling	Input		VDDIO	
PGMM0-PGMM3	Programming Mode	Input		VDDIO	
PGMD0-PGMD15	Programming Data	I/O			
PGMRDY	Programming Ready	Output	High		
PGMNVALID	Data Direction	Output	Low		
PGMNOE	Programming Read	Input	Low		
PGMCK	Programming Clock	Input			
PGMNCMD	Programming Command	Input	Low		
<b>USB Full Speed Device</b>					
DDM	USB Full Speed Data -	Analog, Digital		VDDIO	Reset State: - USB Mode - Internal Pull-down <sup>(3)</sup>
DDP	USB Full Speed Data +				

- Note:
1. Schmitt Triggers can be disabled through PIO registers.
  2. Some PIO lines are shared with System I/Os.
  3. Refer to USB Section of the product Electrical Characteristics for information on Pull-down value in USB Mode.
  4. See “Typical Powering Schematics” Section for restrictions on voltage range of Analog Cells.
  5. TDO pin is set in input mode when the Cortex-M4 Core is not in debug mode. Thus the internal pull-up corresponding to this PIO line must be enabled to avoid current consumption due to floating input.

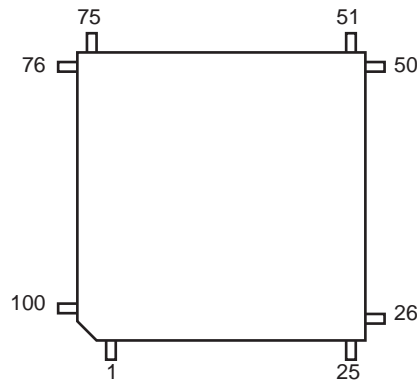
## 4. Package and Pinout

SAM4S devices are pin-to-pin compatible with SAM3N, SAM3S products in 64- and 100-pin versions, and AT91SAM7S legacy products in 64-pin versions.

### 4.1 SAM4SD32/SD16/SA16/S16/S8C Package and Pinout

#### 4.1.1 100-Lead LQFP Package Outline

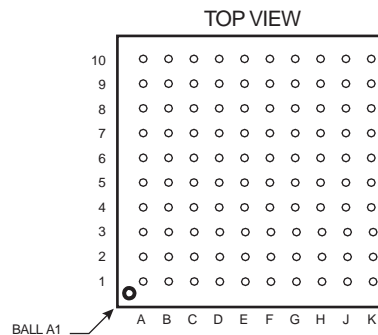
Figure 4-1. Orientation of the 100-lead LQFP Package



#### 4.1.2 100-ball TFBGA Package Outline

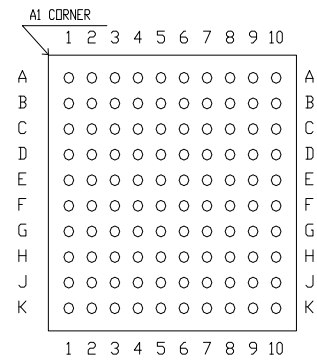
The 100-Ball TFBGA package has a 0.8 mm ball pitch and respects Green Standards. Its dimensions are 9 x 9 x 1.1 mm. Figure 4-2 shows the orientation of the 100-ball TFBGA Package.

Figure 4-2. Orientation of the 100-ball TFBGA Package



## 4.1.3 100-ball VFBGA Package Outline

Figure 4-3. Orientation of the 100-ball VFBGA Package



#### 4.1.4 100-Lead LQFP Pinout

**Table 4-1.** SAM4SD32/SD16/SA16/S16/S8C 100-lead LQFP pinout

1	ADVREF	26	GND	51	TDI/PB4	76	TDO/TRACESWO/ PB5
2	GND	27	VDDIO	52	PA6/PGMNOE	77	JTAGSEL
3	PB0/AD4	28	PA16/PGMD4	53	PA5/PGMRDY	78	PC18
4	PC29/AD13	29	PC7	54	PC28	79	TMS/SWDIO/PB6
5	PB1/AD5	30	PA15/PGMD3	55	PA4/PGMNCMD	80	PC19
6	PC30/AD14	31	PA14/PGMD2	56	VDDCORE	81	PA31
7	PB2/AD6	32	PC6	57	PA27/PGMD15	82	PC20
8	PC31	33	PA13/PGMD1	58	PC8	83	TCK/SWCLK/PB7
9	PB3/AD7	34	PA24/PGMD12	59	PA28	84	PC21
10	VDDIN	35	PC5	60	NRST	85	VDDCORE
11	VDDOUT	36	VDDCORE	61	TST	86	PC22
12	PA17/PGMD5/ AD0	37	PC4	62	PC9	87	ERASE/PB12
13	PC26	38	PA25/PGMD13	63	PA29	88	DDM/PB10
14	PA18/PGMD6/ AD1	39	PA26/PGMD14	64	PA30	89	DDP/PB11
15	PA21/PGMD9/ AD8	40	PC3	65	PC10	90	PC23
16	VDDCORE	41	PA12/PGMD0	66	PA3	91	VDDIO
17	PC27	42	PA11/PGMM3	67	PA2/PGMEN2	92	PC24
18	PA19/PGMD7/ AD12	43	PC2	68	PC11	93	PB13/DAC0
19	PC15/AD11	44	PA10/PGMM2	69	VDDIO	94	PC25
20	PA22/PGMD10/ AD9	45	GND	70	GND	95	GND
21	PC13/AD10	46	PA9/PGMM1	71	PC14	96	PB8/XOUT
22	PA23/PGMD11	47	PC1	72	PA1/PGMEN1	97	PB9/PGMCK/XIN
23	PC12/AD12	48	PA8/XOUT32/ PGMM0	73	PC16	98	VDDIO
24	PA20/PGMD8/ AD3	49	PA7/XIN32/ PGMNVAlID	74	PA0/PGMEN0	99	PB14/DAC1
25	PC0	50	VDDIO	75	PC17	100	VDDPLL

## 4.1.5 100-Ball TFBGA Pinout

**Table 4-2.** SAM4SD32/SD16/SA16/S16/S8 100-ball TFBGA pinout

A1	PB1/AD5	C6	TCK/SWCLK/PB7	F1	PA18/PGMD6/ AD1	H6	PC4
A2	PC29	C7	PC16	F2	PC26	H7	PA11/PGMM3
A3	VDDIO	C8	PA1/PGMEN1	F3	VDDOUT	H8	PC1
A4	PB9/PGMCK/XIN	C9	PC17	F4	GND	H9	PA6/PGMNOE
A5	PB8/XOUT	C10	PA0/PGMEN0	F5	VDDIO	H10	TDI/PB4
A6	PB13/DAC0	D1	PB3/AD7	F6	PA27/PGMD15	J1	PC15/AD11
A7	DDP/PB11	D2	PB0/AD4	F7	PC8	J2	PC0
A8	DDM/PB10	D3	PC24	F8	PA28	J3	PA16/PGMD4
A9	TMS/SWDIO/PB6	D4	PC22	F9	TST	J4	PC6
A10	JTAGSEL	D5	GND	F10	PC9	J5	PA24/PGMD12
B1	PC30	D6	GND	G1	PA21/PGMD9/AD8	J6	PA25/PGMD13
B2	ADVREF	D7	VDDCORE	G2	PC27	J7	PA10/PGMM2
B3	GNDANA	D8	PA2/PGMEN2	G3	PA15/PGMD3	J8	GND
B4	PB14/DAC1	D9	PC11	G4	VDDCORE	J9	VDDCORE
B5	PC21	D10	PC14	G5	VDDCORE	J10	VDDIO
B6	PC20	E1	PA17/PGMD5/ AD0	G6	PA26/PGMD14	K1	PA22/PGMD10/ AD9
B7	PA31	E2	PC31	G7	PA12/PGMD0	K2	PC13/AD10
B8	PC19	E3	VDDIN	G8	PC28	K3	PC12/AD12
B9	PC18	E4	GND	G9	PA4/PGMNCMD	K4	PA20/PGMD8/ AD3
B10	TDO/TRACESWO/ PB5	E5	GND	G10	PA5/PGMRDY	K5	PC5
C1	PB2/AD6	E6	NRST	H1	PA19/PGMD7/ AD2	K6	PC3
C2	VDDPLL	E7	PA29/AD13	H2	PA23/PGMD11	K7	PC2
C3	PC25	E8	PA30/AD14	H3	PC7	K8	PA9/PGMM1
C4	PC23	E9	PC10	H4	PA14/PGMD2	K9	PA8/XOUT32/ PGMM0
C5	ERASE/PB12	E10	PA3	H5	PA13/PGMD1	K10	PA7/XIN32/ PGMINVALID

#### 4.1.6 100-Ball VFBGA Pinout

**Table 4-3.** SAM4SD32/SD16/SA16/S16/S8 100-ball VFBGA pinout

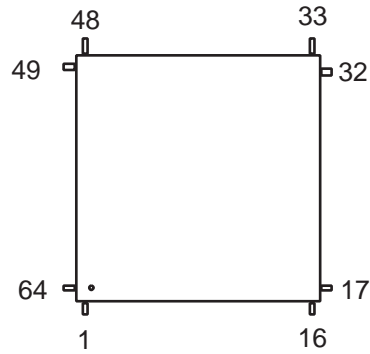
A1	ADVREF	C6	PC9	F1	VDDOUT	H6	PA12/PGMD0
A2	VDDPLL	C7	TMS/SWDIO/PB6	F2	PA18/PGMD6/ AD1	H7	PA9/PGMM1
A3	PB9/PGMCK/XIN	C8	PA1/PGMEN1	F3	PA17/PGMD5/ AD0	H8	VDDCORE
A4	PB8/XOUT	C9	PA0/PGMEN0	F4	GND	H9	PA6/PGMNOE
A5	JTAGSEL	C10	PC16	F5	GND	H10	PA5/PGMRDY
A6	DDP/PB11	D1	PB1/AD5	F6	PC26	J1	PA20/AD3
A7	DDM/PB10	D2	PC30	F7	PA4/PGMNCMD	J2	PC12/AD12
A8	PC20	D3	PC31	F8	PA28	J3	PA16/PGMD4
A9	PC19	D4	PC22	F9	TST	J4	PC6
A10	TDO/TRACESWO/ PB5	D5	PC5	F10	PC8	J5	PA24
B1	GNDANA	D6	PA29/AD13	G1	PC15/AD11	J6	PA25
B2	PC25	D7	PA30/AD14	G2	PA19/PGMD7/ AD2	J7	PA11/PGMM3
B3	PB14/DAC1	D8	GND	G3	PA21/AD8	J8	VDDCORE
B4	PB13/DAC0	D9	PC14	G4	PA15/PGMD3	J9	VDDCORE
B5	PC23	D10	PC11	G5	PC3	J10	TDI/PB4
B6	PC21	E1	VDDIN	G6	PA10/PGMM2	K1	PA23
B7	TCK/SWCLK/PB7	E2	PB3/AD7	G7	PC1	K2	PC0
B8	PA31	E3	PB2/AD6	G8	PC28	K3	PC7
B9	PC18	E4	GND	G9	NRST	K4	PA13/PGMD1
B10	PC17	E5	GND	G10	PA27	K5	PA26
C1	PB0/AD4	E6	GND	H1	PC13/AD10	K6	PC2
C2	PC29	E7	VDDIO	H2	PA22/AD9	K7	VDDIO
C3	PC24	E8	PC10	H3	PC27	K8	VDDIO
C4	ERASE/PB12	E9	PA2/PGMEN2	H4	PA14/PGMD2	K9	PA8/XOUT32/ PGMM0
C5	VDDCORE	E10	PA3	H5	PC4	K10	PA7/XIN32/ PGMNVALID



## 4.2 SAM4SD32/SD16/SA16/S16/S8 Package and Pinout

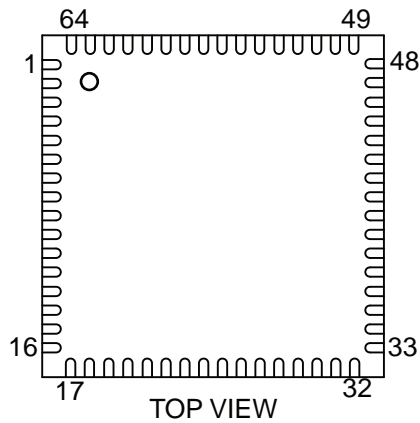
### 4.2.1 64-Lead LQFP Package Outline

Figure 4-4. Orientation of the 64-lead LQFP Package



### 4.2.2 64-lead QFN Package Outline

Figure 4-5. Orientation of the 64-lead QFN Package



### 4.2.3 64-Lead LQFP and QFN Pinout

**Table 4-4.** 64-pin SAM4SD32/SD16/SA16/S16/S8 pinout

1	ADVREF	17	GND	33	TDI/PB4	49	TDO/TRACESWO/ PB5
2	GND	18	VDDIO	34	PA6/PGMNOE	50	JTAGSEL
3	PB0/AD4	19	PA16/PGMD4	35	PA5/PGMRDY	51	TMS/SWDIO/PB6
4	PB1/AD5	20	PA15/PGMD3	36	PA4/PGMNCMD	52	PA31
5	PB2/AD6	21	PA14/PGMD2	37	PA27/PGMD15	53	TCK/SWCLK/PB7
6	PB3/AD7	22	PA13/PGMD1	38	PA28	54	VDDCORE
7	VDDIN	23	PA24/PGMD12	39	NRST	55	ERASE/PB12
8	VDDOUT	24	VDDCORE	40	TST	56	DDM/PB10
9	PA17/PGMD5/ AD0	25	PA25/PGMD13	41	PA29	57	DDP/PB11
10	PA18/PGMD6/ AD1	26	PA26/PGMD14	42	PA30	58	VDDIO
11	PA21/PGMD9/ AD8	27	PA12/PGMD0	43	PA3	59	PB13/DAC0
12	VDDCORE	28	PA11/PGMM3	44	PA2/PGMEN2	60	GND
13	PA19/PGMD7/ AD2	29	PA10/PGMM2	45	VDDIO	61	XOUT/PB8
14	PA22/PGMD10/ AD9	30	PA9/PGMM1	46	GND	62	XIN/PGMCK/PB9
15	PA23/PGMD11	31	PA8/XOUT32/ PGMM0	47	PA1/PGMEN1	63	PB14/DAC1
16	PA20/PGMD8/ AD3	32	PA7/XIN32/ PGMINVALID	48	PA0/PGMEN0	64	VDDPLL

Note: The bottom pad of the QFN package must be connected to ground.

## 5. Power Considerations

### 5.1 Power Supplies

The SAM4S has several types of power supply pins:

- VDDCORE pins: Power the core, the embedded memories and the peripherals. Voltage ranges from 1.08V to 1.32V.
- VDDIO pins: Power the Peripherals I/O lines (Input/Output Buffers), USB transceiver, Backup part, 32 kHz crystal oscillator and oscillator pads. Voltage ranges from 1.62V to 3.6V.
- VDDIN pin: Voltage Regulator Input, ADC, DAC and Analog Comparator Power Supply. Voltage ranges from 1.62V to 3.6V.
- VDDPLL pin: Powers the PLLA, PLLB, the Fast RC and the 3 to 20 MHz oscillator. Voltage ranges from 1.08V to 1.32V.

### 5.2 Voltage Regulator

The SAM4S embeds a voltage regulator that is managed by the Supply Controller.

This internal regulator is designed to supply the internal core of SAM4S. It features two operating modes:

- In Normal mode, the voltage regulator consumes less than 500  $\mu$ A static current and draws 80 mA of output current. Internal adaptive biasing adjusts the regulator quiescent current depending on the required load current. In Wait Mode quiescent current is only 5  $\mu$ A.
- In Backup mode, the voltage regulator consumes less than 1  $\mu$ A while its output (VDDOUT) is driven internally to GND. The default output voltage is 1.20V and the start-up time to reach Normal mode is less than 300  $\mu$ s.

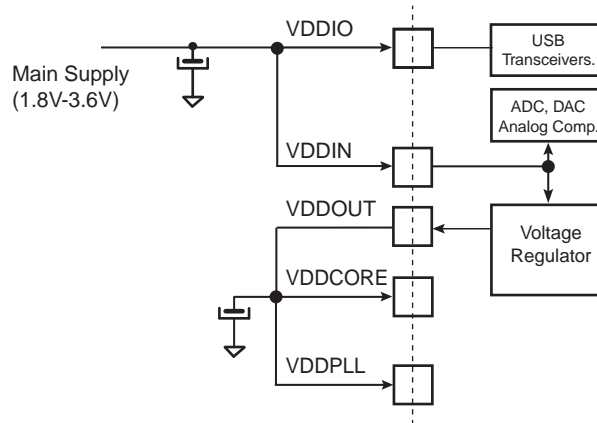
For adequate input and output power supply decoupling/bypassing, refer to the “Voltage Regulator” section in the “Electrical Characteristics” section of the datasheet.

### 5.3 Typical Powering Schematics

The SAM4S supports a 1.62V-3.6V single supply mode. The internal regulator input is connected to the source and its output feeds VDDCORE. [Figure 5-1](#) below shows the power schematics.

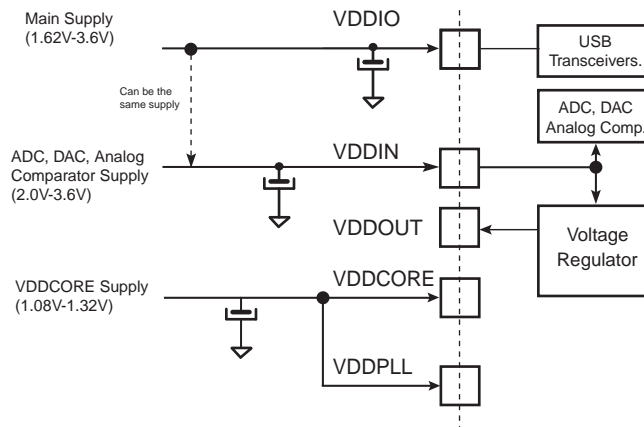
As VDDIN powers the voltage regulator, the ADC, DAC and the analog comparator, when the user does not want to use the embedded voltage regulator, it can be disabled by software via the SUPC (note that this is different from Backup mode).

**Figure 5-1.** Single Supply



Note: Restrictions  
 For USB, VDDIO needs to be greater than 3.0V.  
 For ADC, VDDIN needs to be greater than 2.0V.  
 For DAC, VDDIN needs to be greater than 2.4V.

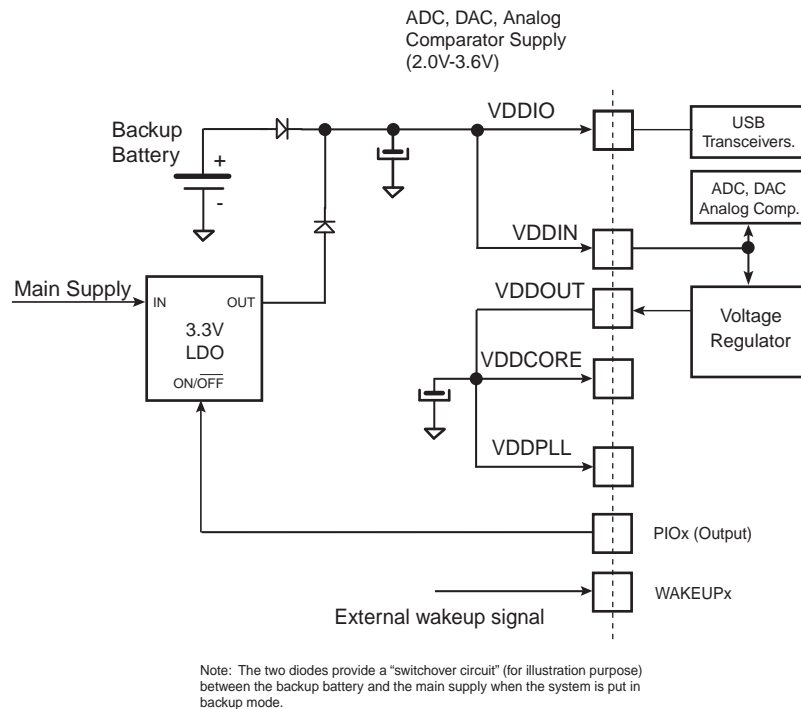
**Figure 5-2.** Core Externally Supplied



Note: Restrictions  
 For USB, VDDIO needs to be greater than 3.0V.  
 For ADC, VDDIN needs to be greater than 2.0V.  
 For DAC, VDDIN needs to be greater than 2.4V.

Figure 5-3 below provides an example of the powering scheme when using a backup battery. Since the PIO state is preserved when in backup mode, any free PIO line can be used to switch off the external regulator by driving the PIO line at low level (PIO is input, pull-up enabled after backup reset). External wake-up of the system can be from a push button or any signal. See Section 5.6 “Wake-up Sources” for further details.

**Figure 5-3. Backup Battery**



## 5.4 Active Mode

Active mode is the normal running mode with the core clock running from the fast RC oscillator, the main crystal oscillator or the PLLA. The power management controller can be used to adapt the frequency and to disable the peripheral clocks.

## 5.5 Low-Power Modes

The various low-power modes of the SAM4S are described below:

### 5.5.1 Backup Mode

The purpose of backup mode is to achieve the lowest power consumption possible in a system which is performing periodic wake-ups to perform tasks but not requiring fast startup time. Total current consumption is 1  $\mu$ A typical ( $V_{DDIO} = 1.8V$  to 25°C).

The Supply Controller, zero-power power-on reset, RTT, RTC, Backup registers and 32 kHz oscillator (RC or crystal oscillator selected by software in the Supply Controller) are running. The regulator and the core supply are off.

Backup mode is based on the Cortex-M4 deep sleep mode with the voltage regulator disabled.

The SAM4S can be awakened from this mode through WUP0-15 pins, the supply monitor (SM), the RTT or RTC wake-up event.

Backup mode is entered by writing the Supply Controller Control Register (SUPC\_CR) with the VROFF bit at 1 (a key is needed to write the VROFF bit, please refer to the "Supply Controller (SUPC)" section of the product datasheet) and with the SLEEPDEEP bit in the Cortex-M4 System Control Register set to 1. (See the Power management description in the "ARM Cortex-M4 Processor" section of the product datasheet).

Entering Backup mode:

- Set the SLEEPDEEP bit of Cortex\_M4 to 1
- Set the VROFF bit of SUPC\_CR to 1

Exit from Backup mode happens if one of the following enable wake up events occurs:

- WKUPEN0-15 pins (level transition, configurable debouncing)
- Supply Monitor alarm
- RTC alarm
- RTT alarm

## 5.5.2 Wait Mode

The purpose of the wait mode is to achieve very low power consumption while maintaining the whole device in a powered state for a startup time of less than 10  $\mu$ s. Current Consumption in Wait mode is typically 32  $\mu$ A (total current consumption) if the internal voltage regulator is used.

In this mode, the clocks of the core, peripherals and memories are stopped. However, the core, peripherals and memories power supplies are still powered. From this mode, a fast start up is available.

This mode is entered by setting WAITMODE bit to 1 (in PMC clock generator Main Oscillator register) with LPM = 1 (Low Power Mode bit in PMC\_FSMR) and with FLPM = 00 or FLPM=01 (Flash Low Power Mode bits in PMC\_FSMR).

The Cortex-M4 is able to handle external events or internal events in order to wake-up the core. This is done by configuring the external lines WUP0-15 as fast startup wake-up pins (refer to [Section 5.7 “Fast Startup”](#)). RTC or RTT Alarm and USB wake-up events can be used to wake up the CPU.

Entering Wait Mode:

- Select the 4/8/12 MHz fast RC oscillator as Main Clock
- Set the LPM bit in the PMC Fast Startup Mode Register (PMC\_FSMR)
- Set the FLPM bitfield in the PMC Fast Startup Mode Register (PMC\_FSMR)
- Set Flash Wait State at 0.
- Set the WAITMODE bit = 1 in PMC Main Oscillator Register (CKGR\_MOR)
- Wait for Master Clock Ready MCKRDY = 1 in the PMC Status Register (PMC\_SR)

Note: Internal Main clock resynchronization cycles are necessary between the writing of MOSRCEN bit and the effective entry in Wait mode. Depending on the user application, waiting for MOSRCEN bit to be cleared is recommended to ensure that the core will not execute undesired instructions.

Depending on Flash Low Power Mode (FLPM) value, the Flash will enter in three different modes:

- FLPM[00] in Standby mode
- FLPM[01] in Deep Power Down mode
- FLPM[10] in mode Idle.

Following the Flash mode selection, the consumption in wait mode will decrease. In Deep Power Down mode the recovery time of the Flash in Standby mode will be less than the power up delay.

## 5.5.3 Sleep Mode

The purpose of sleep mode is to optimize power consumption of the device versus response time. In this mode, only the core clock is stopped. The peripheral clocks can be enabled. The current consumption in this mode is application dependent.

This mode is entered via Wait for Interrupt (WFI) instructions with LPM = 0 in PMC\_FSMR.

The processor can be awakened from an interrupt if WFI instruction of the Cortex-M4 is used.

## 5.5.4 Low Power Mode Summary Table

The modes detailed above are the main low-power modes. Each part can be set to on or off separately and wake up sources can be individually configured. [Table 5-1](#) below shows a summary of the configurations of the low-power modes.

**Table 5-1.** Low-power Mode Configuration Summary

Mode	SUPC, 32 kHz Osc, RTC, RTT Backup Registers, POR (Backup Region)	Regulator	Core Memory Peripherals	Mode Entry	Potential Wake Up Sources	Core at Wake Up	PIO State while in Low Power Mode	PIO State at Wake Up	Consumption <sup>(1) (2)</sup>	Wake-up Time <sup>(3)</sup>
Backup Mode	ON	OFF	OFF (Not powered)	VROFF bit = 1 +SLEEPDEEP bit = 1	WUP0-15 pins SM alarm RTC alarm RTT alarm	Reset	Previous state saved	PIOA & PIOB & PIOC Inputs with pull ups	1 $\mu$ A typ <sup>(4)</sup>	300 ms
Wait Mode w/Flash in Standby mode	ON	ON	Powered (Not clocked)	WAITMODE bit = 1 +SLEEPDEEP bit = 0 +LPM bit = 1 FLPM0 bit = 0 FLPM1 bit = 0	Any Event from: Fast startup through WUP0-15 pins RTC alarm RTT alarm USB wake-up	Clocked back	Previous state saved	Unchanged	32.2 $\mu$ A <sup>(5)</sup>	< 10 $\mu$ s
Wait Mode w/Flash in Deep Power Down mode	ON	ON	Powered (Not clocked)	WAITMODE bit = 1 +SLEEPDEEP bit = 0 +LPM bit = 1 FLPM0 bit = 0 FLPM1 bit = 1	Any Event from: Fast startup through WUP0-15 pins RTC alarm RTT alarm USB wake-up	Clocked back	Previous state saved	Unchanged	27.6 $\mu$ A	< 10 $\mu$ s
Sleep Mode	ON	ON	Powered <sup>(6)</sup> (Not clocked)	WFI +SLEEPDEEP bit = 0 +LPM bit = 0	Entry mode =WFI Interrupt Only; Any Enabled Interrupt and/or Any Event from: Fast start-up through WUP0-15 pins RTC alarm RTT alarm USB wake-up	Clocked back	Previous state saved	Unchanged <sup>(7)</sup>	<sup>(7)</sup>	<sup>(7)</sup>

Notes: 1. The external loads on PIOs are not taken into account in the calculation.

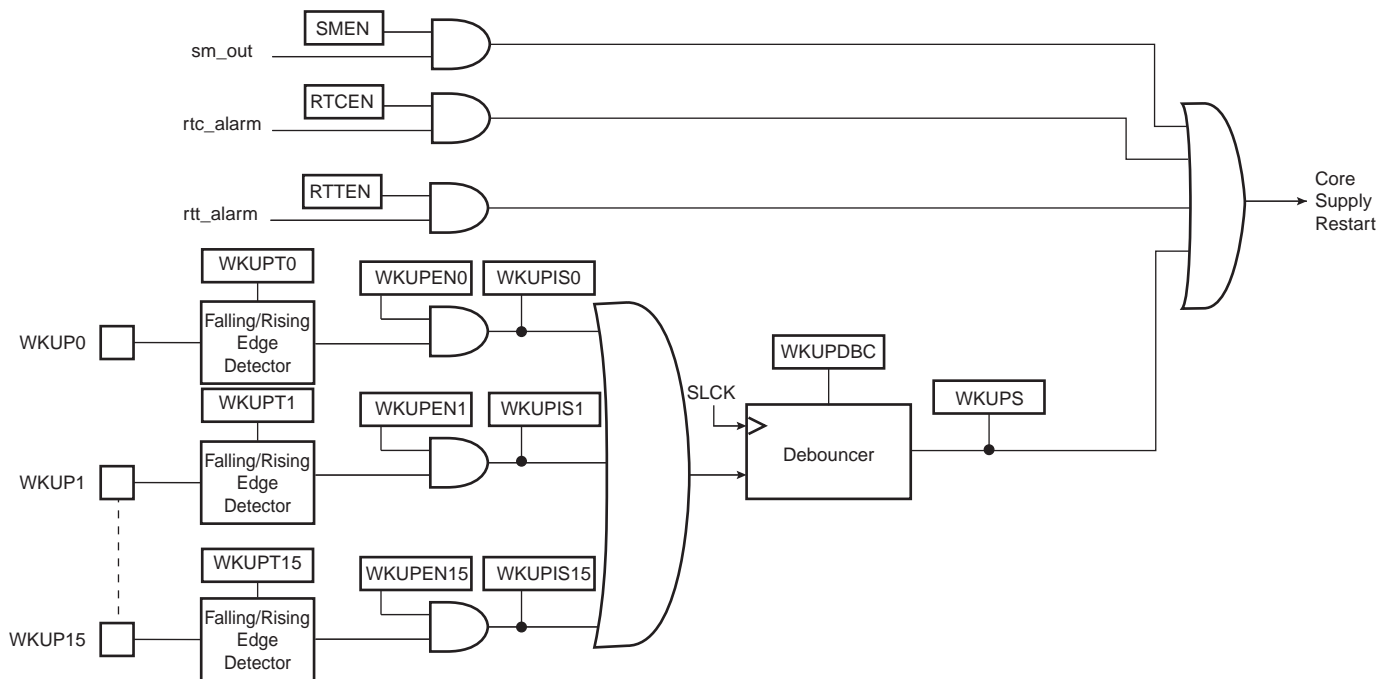
2. Supply Monitor current consumption is not included.

3. When considering wake-up time, the time required to start the PLL is not taken into account. Once started, the device works with the 4/8/12 MHz fast RC oscillator. The user has to add the PLL start-up time if it is needed in the system. The wake-up time is defined as the time taken for wake up until the first instruction is fetched.
4. Total Current consumption, 1  $\mu$ A typ to 1.8V on VDDIO to 25°C.
5. 20.4  $\mu$ A on VDDCORE, 32.2  $\mu$ A for total current consumption
6. In this mode the core is supplied and not clocked but some peripherals can be clocked.
7. Depends on MCK frequency. In this mode, the core is supplied but some peripherals can be clocked.

## 5.6 Wake-up Sources

The wake-up events allow the device to exit the backup mode. When a wake-up event is detected, the Supply Controller performs a sequence which automatically reenables the core power supply and the SRAM power supply, if they are not already enabled.

**Figure 5-4.** Wake-up Source



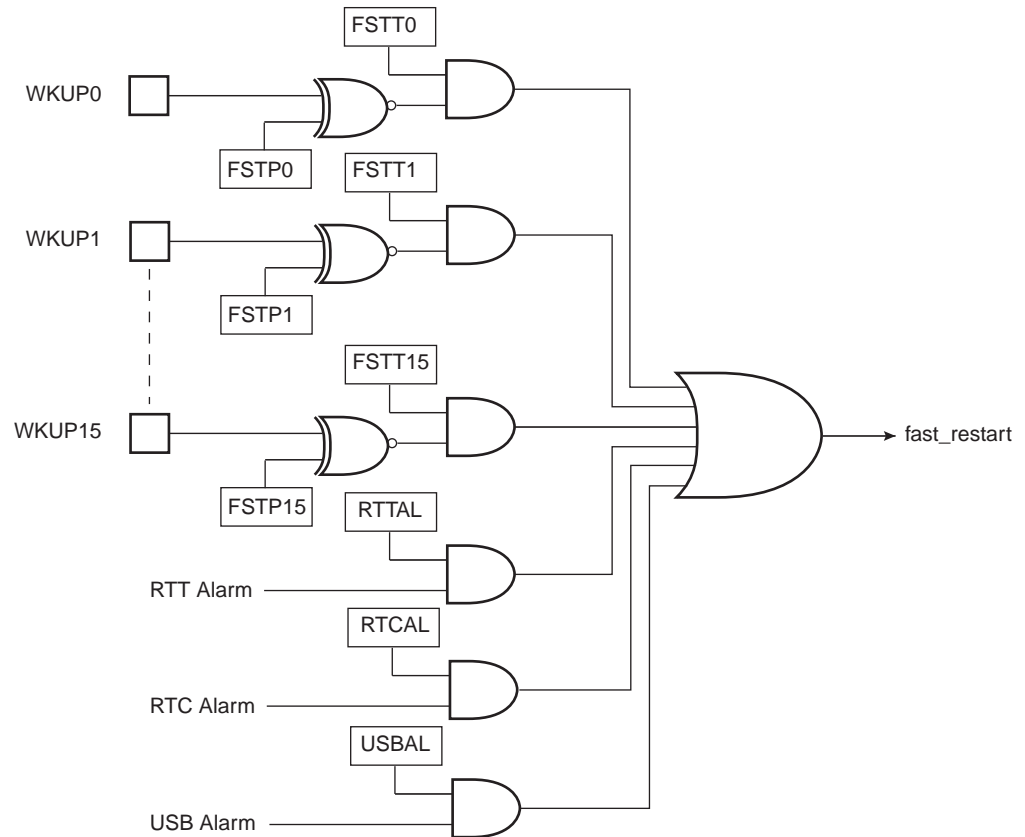


## 5.7 Fast Startup

The SAM4S allows the processor to restart in a few microseconds while the processor is in wait mode or in sleep mode. A fast start up can occur upon detection of a low level on one of the 19 wake-up inputs (WKUP0 to 15 + SM + RTC + RTT).

The fast restart circuitry, as shown in Figure 5-5, is fully asynchronous and provides a fast start-up signal to the Power Management Controller. As soon as the fast start-up signal is asserted, the PMC automatically restarts the embedded 4/8/12 MHz Fast RC oscillator, switches the master clock on this 4 MHz clock and reenables the processor clock.

**Figure 5-5.** Fast Start-Up Sources



## 6. Input/Output Lines

The SAM4S has several kinds of input/output (I/O) lines such as general purpose I/Os (GPIO) and system I/Os. GPIOs can have alternate functionality due to multiplexing capabilities of the PIO controllers. The same PIO line can be used whether in I/O mode or by the multiplexed peripheral. System I/Os include pins such as test pins, oscillators, erase or analog inputs.

### 6.1 General Purpose I/O Lines

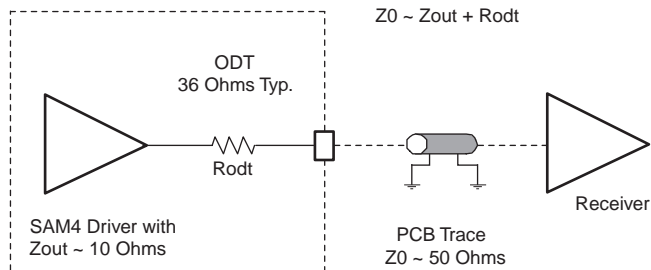
GPIO Lines are managed by PIO Controllers. All I/Os have several input or output modes such as pull-up or pull-down, input Schmitt triggers, multi-drive (open-drain), glitch filters, debouncing or input change interrupt. Programming of these modes is performed independently for each I/O line through the PIO controller user interface. For more details, refer to the product “PIO Controller” section.

The input/output buffers of the PIO lines are supplied through VDDIO power supply rail.

The SAM4S embeds high speed pads able to handle up to 70 MHz for HSMCI (MCK/2), 70 MHz for SPI clock lines and 46 MHz on other lines. See the “AC Characteristics” sub-section of the product Electrical Characteristics. Typical pull-up and pull-down value is 100 kΩ for all I/Os.

Each I/O line also embeds an ODT (On-Die Termination), (see [Figure 6-1](#) below). It consists of an internal series resistor termination scheme for impedance matching between the driver output (SAM4S) and the PCB trace impedance preventing signal reflection. The series resistor helps to reduce IOs switching current (di/dt) thereby reducing in turn, EMI. It also decreases overshoot and undershoot (ringing) due to inductance of interconnect between devices or between boards. In conclusion ODT helps diminish signal integrity issues.

**Figure 6-1.** On-Die Termination



### 6.2 System I/O Lines

System I/O lines are pins used by oscillators, test mode, reset and JTAG to name but a few. Described below in [Table 6-1](#) are the SAM4S system I/O lines shared with PIO lines.

These pins are software configurable as general purpose I/O or system pins. At startup the default function of these pins is always used.

**Table 6-1.** System I/O Configuration Pin List.

SYSTEM_IO bit number	Default function after reset	Other function	Constraints for normal start	Configuration
12	ERASE	PB12	Low Level at startup <sup>(1)</sup>	In Matrix User Interface Registers (Refer to the System I/O Configuration Register in the “Bus Matrix” section of the datasheet.)
10	DDM	PB10	-	
11	DDP	PB11	-	
7	TCK/SWCLK	PB7	-	
6	TMS/SWDIO	PB6	-	
5	TDO/TRACESWO	PB5	-	
4	TDI	PB4	-	
-	PA7	XIN32	-	See footnote <sup>(2)</sup> below
-	PA8	XOUT32	-	
-	PB9	XIN	-	See footnote <sup>(3)</sup> below
-	PB8	XOUT	-	

- Notes:
1. If PB12 is used as PIO input in user applications, a low level must be ensured at startup to prevent Flash erase before the user application sets PB12 into PIO mode,
  2. In the product Datasheet refer to: “Slow Clock Generator” of the “Supply Controller” section.
  3. In the product Datasheet refer to: “3 to 20 MHz Crystal Oscillator” information in the “PMC” section.

## 6.2.1 Serial Wire JTAG Debug Port (SWJ-DP) Pins

The SWJ-DP pins are TCK/SWCLK, TMS/SWDIO, TDO/SWO, TDI and commonly provided on a standard 20-pin JTAG connector defined by ARM. For more details about voltage reference and reset state, refer to [Table 3-1 on page 8](#).

At startup, SWJ-DP pins are configured in SWJ-DP mode to allow connection with debugging probe. Please refer to the “Debug and Test” Section of the product datasheet.

SWJ-DP pins can be used as standard I/Os to provide users more general input/output pins when the debug port is not needed in the end application. Mode selection between SWJ-DP mode (System IO mode) and general IO mode is performed through the AHB Matrix Special Function Registers (MATRIX\_SFR). Configuration of the pad for pull-up, triggers, debouncing and glitch filters is possible regardless of the mode.

The JTAGSEL pin is used to select the JTAG boundary scan when asserted at a high level. It integrates a permanent pull-down resistor of about 15 kΩ to GND, so that it can be left unconnected for normal operations.

By default, the JTAG Debug Port is active. If the debugger host wants to switch to the Serial Wire Debug Port, it must provide a dedicated JTAG sequence on TMS/SWDIO and TCK/SWCLK which disables the JTAG-DP and enables the SW-DP. When the Serial Wire Debug Port is active, TDO/TRACESWO can be used for trace.

The asynchronous TRACE output (TRACESWO) is multiplexed with TDO. So the asynchronous trace can only be used with SW-DP, not JTAG-DP. For more information about SW-DP and JTAG-DP switching, please refer to the “Debug and Test” Section.

### 6.3 Test Pin

The TST pin is used for JTAG Boundary Scan Manufacturing Test or Fast Flash programming mode of the SAM4S series. The TST pin integrates a permanent pull-down resistor of about 15 k $\Omega$  to GND, so that it can be left unconnected for normal operations. To enter fast programming mode, see the Fast Flash Programming Interface (FFPI) section. For more details on the manufacturing and test mode, refer to the “Debug and Test” section of the product datasheet.

### 6.4 NRST Pin

The NRST pin is bidirectional. It is handled by the on-chip reset controller and can be driven low to provide a reset signal to the external components or asserted low externally to reset the microcontroller. It will reset the Core and the peripherals except the Backup region (RTC, RTT and Supply Controller). There is no constraint on the length of the reset pulse and the reset controller can guarantee a minimum pulse length. The NRST pin integrates a permanent pull-up resistor to VDDIO of about 100 k $\Omega$ . By default, the NRST pin is configured as an input.

### 6.5 ERASE Pin

The ERASE pin is used to reinitialize the Flash content (and some of its NVM bits) to an erased state (all bits read as logic level 1). It integrates a pull-down resistor of about 100 k $\Omega$  to GND, so that it can be left unconnected for normal operations.

This pin is debounced by SCLK to improve the glitch tolerance. When the ERASE pin is tied high during less than 100 ms, it is not taken into account. The pin must be tied high during more than 220 ms to perform a Flash erase operation.

The ERASE pin is a system I/O pin and can be used as a standard I/O. At startup, the ERASE pin is not configured as a PIO pin. If the ERASE pin is used as a standard I/O, startup level of this pin must be low to prevent unwanted erasing. Refer to [Section 10.16 “Peripheral Signal Multiplexing on I/O Lines” on page 48](#). Also, if the ERASE pin is used as a standard I/O output, asserting the pin to low does not erase the Flash.

## 7. Processor and Architecture

### 7.1 ARM Cortex-M4 Processor

- Thumb-2 (ISA) subset consisting of all base Thumb-2 instructions, 16-bit and 32-bit
- Harvard processor architecture enabling simultaneous instruction fetch with data load/store
- Three-stage pipeline
- Saturating arithmetic for signal processing
- Hardware division and fast digital-signal-processing oriented multiply accumulate
- Thumb and Debug states
- Handler and Thread modes
- Low latency ISR entry and exit

### 7.2 APB/AHB bridge

The SAM4S embeds One Peripheral bridge.

The peripherals of the bridge are clocked by MCK.

### 7.3 Matrix Masters

The Bus Matrix of the SAM4S manages 4 masters, which means that each master can perform an access concurrently with others, to an available slave.

Each master has its own decoder, which is defined specifically for each master. In order to simplify the addressing, all the masters have the same decodings.

**Table 7-1.** List of Bus Matrix Masters

Master 0	Cortex-M4 Instruction/Data
Master 1	Cortex-M4 System
Master 2	Peripheral DMA Controller (PDC)
Master 3	CRC Calculation Unit

### 7.4 Matrix Slaves

The Bus Matrix of the SAM4S manages 5 slaves. Each slave has its own arbiter, allowing a different arbitration per slave.

**Table 7-2.** List of Bus Matrix Slaves

Slave 0	Internal SRAM
Slave 1	Internal ROM
Slave 2	Internal Flash
Slave 3	External Bus Interface
Slave 4	Peripheral Bridge

## 7.5 Master to Slave Access

All the Masters can normally access all the Slaves. However, some paths do not make sense, for example allowing access from the Cortex-M4 S Bus to the Internal ROM. Thus, these paths are forbidden or simply not wired, and shown as “-” in the following table.

**Table 7-3.** SAM4S Master to Slave Access

Slaves	Masters	0	1	2	3
		Cortex-M4 I/D Bus	Cortex-M4 S Bus	PDC	CRCCU
0	Internal SRAM	-	X	X	X
1	Internal ROM	X	-	X	X
2	Internal Flash	X	-	-	X
3	External Bus Interface	-	X	X	X
4	Peripheral Bridge	-	X	X	-

## 7.6 Peripheral DMA Controller

- Handles data transfer between peripherals and memories
- Low bus arbitration overhead
  - One Master Clock cycle needed for a transfer from memory to peripheral
  - Two Master Clock cycles needed for a transfer from peripheral to memory
- Next Pointer management for reducing interrupt latency requirement

The Peripheral DMA Controller handles transfer requests from the channel according to the following priorities (Low to High priorities):

**Table 7-4.** Peripheral DMA Controller

Instance name	Channel T/R
PWM	Transmit
TWI1	Transmit
TWI0	Transmit
UART1	Transmit
UART0	Transmit
USART1	Transmit
USART0	Transmit
DACC	Transmit
SPI	Transmit
SSC	Transmit
HSMCI	Transmit

**Table 7-4.** Peripheral DMA Controller

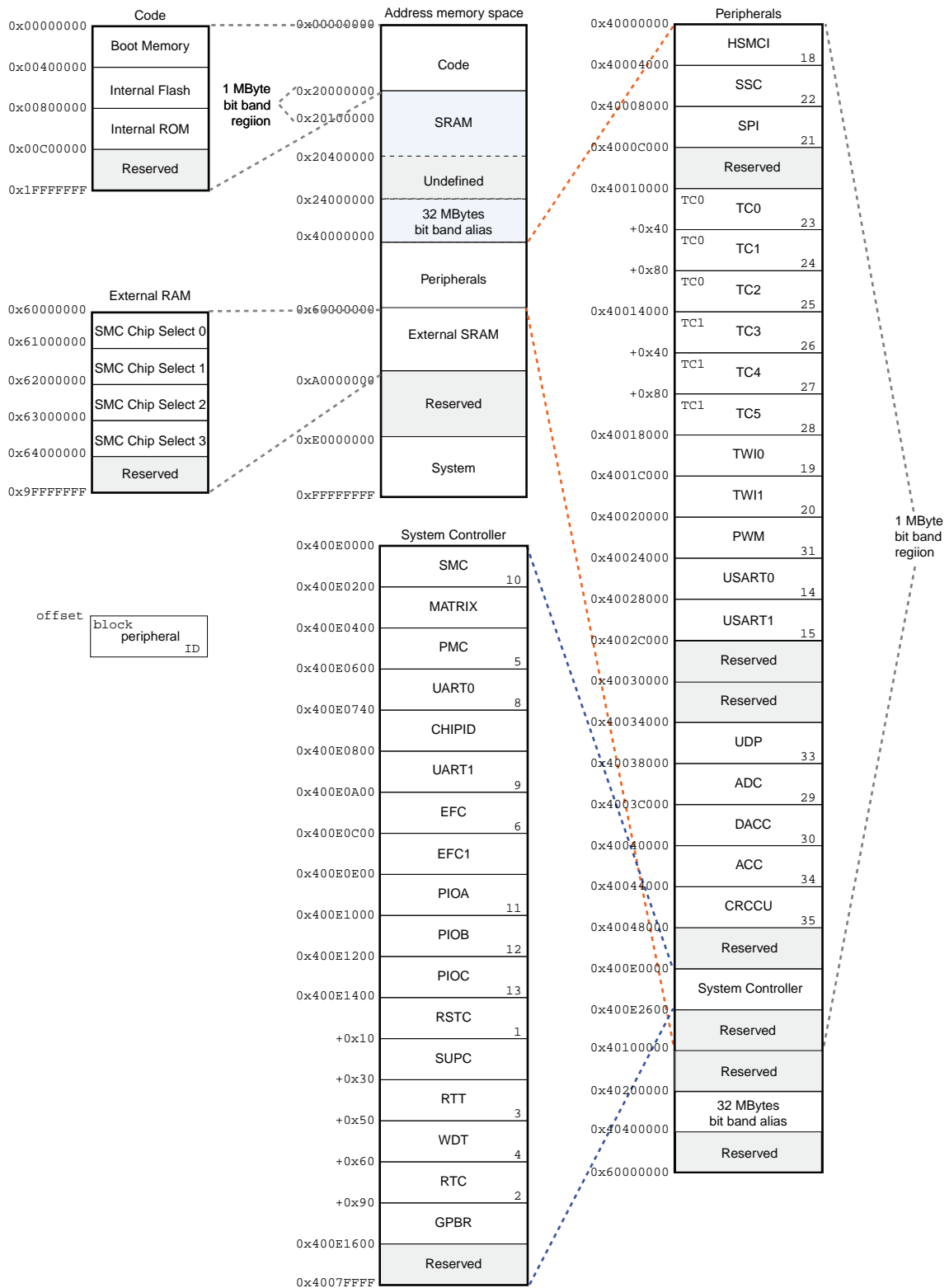
Instance name	Channel T/R
PIOA	Receive
TWI1	Receive
TWI0	Receive
UART1	Receive
UART0	Receive
USART1	Receive
USART0	Receive
ADC	Receive
SPI	Receive
SSC	Receive
HSMCI	Receive

## 7.7 Debug and Test Features

- Debug access to all memory and registers in the system, including Cortex-M4 register bank when the core is running, halted, or held in reset.
- Serial Wire Debug Port (SW-DP) and Serial Wire JTAG Debug Port (SWJ-DP) debug access
- Flash Patch and Breakpoint (FPB) unit for implementing breakpoints and code patches
- Data Watchpoint and Trace (DWT) unit for implementing watch points, data tracing, and system profiling
- Instrumentation Trace Macrocell (ITM) for support of printf style debugging
- IEEE®1149.1 JTAG Boundary scan on All Digital Pins

## 8. Product Mapping

Figure 8-1. SAM4S Product Mapping





## 9. Memories

### 9.1 Embedded Memories

#### 9.1.1 Internal SRAM

The SAM4SD32 device (2x1024 Kbytes) embeds a total of 160-Kbytes high-speed SRAM.

The SAM4SD16 device (2x512Kbytes)embeds a total of 160-Kbytes high-speed SRAM.

The SAM4SA16 device (1024 Kbytes) embeds a total of 160-Kbytes high-speed SRAM.

The SAM4S16 device (1024 Kbytes) embeds a total of 128-Kbytes high-speed SRAM.

The SAM4S8 device (512 Kbytes) embeds a total of 128-Kbytes high-speed SRAM.

The SRAM is accessible over System Cortex-M4 bus at address 0x2000 0000.

The SRAM is in the bit band region. The bit band alias region is from 0x2200 0000 to 0x23FF FFFF.

#### 9.1.2 Internal ROM

The SAM4S embeds an Internal ROM, which contains the SAM Boot Assistant (SAM-BA<sup>®</sup>), In Application Programming routines (IAP) and Fast Flash Programming Interface (FFPI).

At any time, the ROM is mapped at address 0x0080 0000.

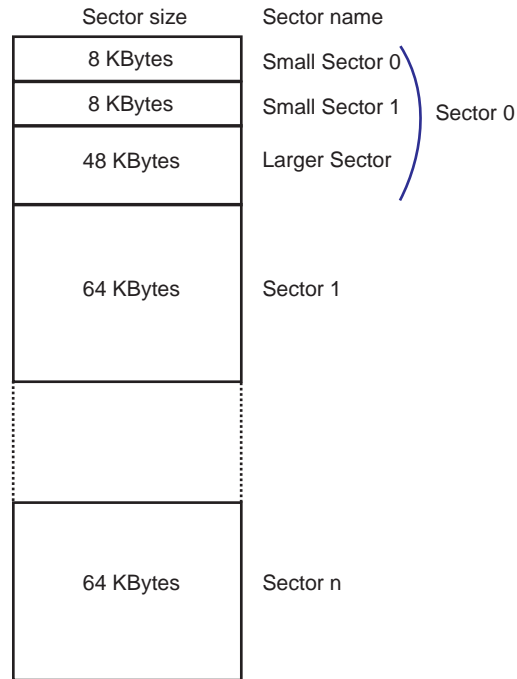
#### 9.1.3 Embedded Flash

##### 9.1.3.1 Flash Overview

The memory is organized in sectors. Each sector has a size of 64 Kbytes. The first sector of 64 Kbytes is divided into 3 smaller sectors.

The three smaller sectors are organized to consist of 2 sectors of 8 Kbytes and 1 sector of 48 Kbytes. Refer to [Figure 9-1, "Global Flash Organization"](#) below.

**Figure 9-1.** Global Flash Organization



Each Sector is organized in pages of 512 Bytes.

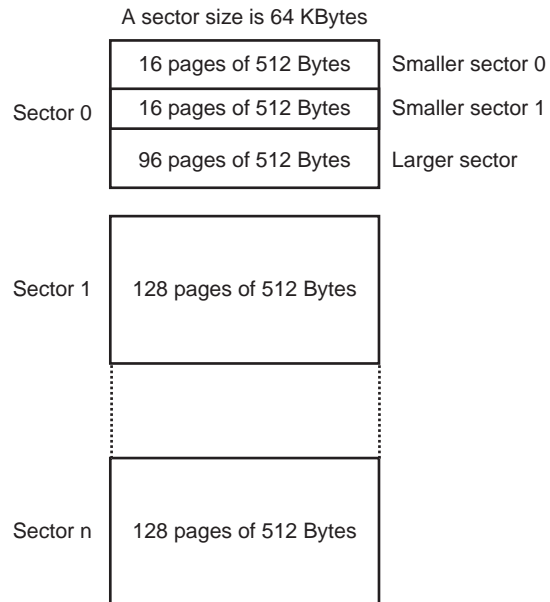
For sector 0:

- The smaller sector 0 has 16 pages of 512Bytes
- The smaller sector 1 has 16 pages of 512 Bytes
- The larger sector has 96 pages of 512 Bytes

From Sector 1 to n:

The rest of the array is composed of 64-Kbyte sectors of 128 pages, each page of 512 bytes. Refer to [Figure 9-2, "Flash Sector Organization"](#) below.

**Figure 9-2.** Flash Sector Organization

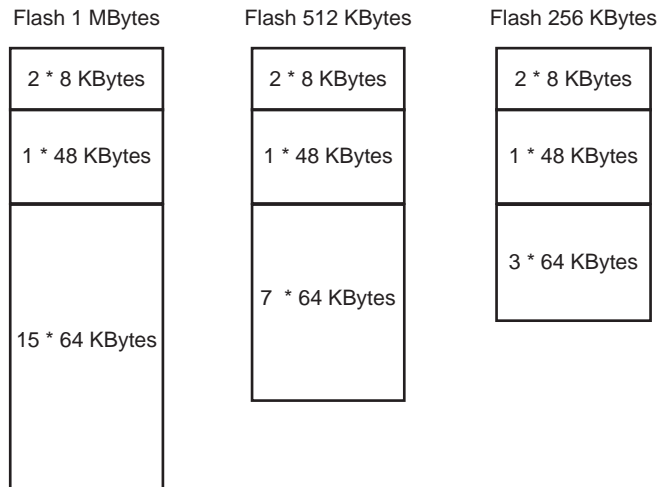


Flash size varies by product:

- SAM4S8: the Flash size is 512 Kbytes
  - Internal Flash address is 0x0040\_0000
- SAM4SD16/SA16: the Flash size is 2 x 512 Kbytes
  - Internal Flash0 address is 0x0040\_0000
  - Internal Flash1 address is 0x0048\_0000
- SAM4SD32: the Flash size is 2 x 1024 Kbytes
  - Internal Flash0 address is 0x0040\_0000
  - Internal Flash1 address is 0x0050\_0000

Refer to [Figure 9-3, "Flash Size"](#) below for the organization of the Flash following its size.

**Figure 9-3.** Flash Size



Erasing the memory can be performed as follows:

- on a 512-byte page inside a sector, of 8Kbytes

Note: EWP and EWPL commands can be only used in 8Kbytes sectors.

- on a 4-Kbyte Block inside a sector of 8 Kbytes/48 Kbytes/64 Kbytes
- on a sector of 8 Kbytes/48 Kbytes/64 Kbytes
- on chip

#### 9.1.3.2 *Enhanced Embedded Flash Controller*

The Enhanced Embedded Flash Controller manages accesses performed by the masters of the system. It enables reading the Flash and writing the write buffer. It also contains a User Interface, mapped on the APB.

The Enhanced Embedded Flash Controller ensures the interface of the Flash block.

It manages the programming, erasing, locking and unlocking sequences of the Flash using a full set of commands.

One of the commands returns the embedded Flash descriptor definition that informs the system about the Flash organization, thus making the software generic.

#### 9.1.3.3 *Flash Speed*

The user needs to set the number of wait states depending on the frequency used:

For more details, refer to the “AC Characteristics” sub-section of the product “Electrical Characteristics”.

## 9.1.3.4 Lock Regions

Several lock bits are used to protect write and erase operations on lock regions. A lock region is composed of several consecutive pages, and each lock region has its associated lock bit.

**Table 9-1.** Lock bit number

Product	Number of lock bits	Lock region size
SAM4SD32	256 (128 + 128)	8 Kbytes
SAM4SD16	128 (64 + 64)	8 Kbytes
SAM4SA16	128	8 Kbytes
SAM4S8	64	8 Kbytes

If a locked-region's erase or program command occurs, the command is aborted and the EEFC triggers an interrupt.

The lock bits are software programmable through the EEFC User Interface. The command "Set Lock Bit" enables the protection. The command "Clear Lock Bit" unlocks the lock region.

Asserting the ERASE pin clears the lock bits, thus unlocking the entire Flash.

## 9.1.3.5 Security Bit Feature

The SAM4SD32 and SAM4SD16 feature 2 security bits, the SAM4S16/SA16/S8 feature a security bit, based on a specific General Purpose NVM bit (GPNVM bit 0). When one of the security bits is enabled, any access to the Flash, SRAM, Core Registers and Internal Peripherals either through the ICE interface or through the Fast Flash Programming Interface, is forbidden. This ensures the confidentiality of the code programmed in the Flash.

This security bit can only be enabled, through the command "Set General Purpose NVM Bit 0" of the EEFC User Interface. Disabling the security bit can only be achieved by asserting the ERASE pin at 1, and after a full Flash erase is performed. When the security bit is deactivated, all accesses to the Flash, SRAM, Core registers, Internal Peripherals are permitted.

It is important to note that the assertion of the ERASE pin should always be longer than 200 ms.

As the ERASE pin integrates a permanent pull-down, it can be left unconnected during normal operation. However, it is safer to connect it directly to GND for the final application.

## 9.1.3.6 Calibration Bits

NVM bits are used to calibrate the brownout detector and the voltage regulator. These bits are factory configured and cannot be changed by the user. The ERASE pin has no effect on the calibration bits.

## 9.1.3.7 Unique Identifier

Each device integrates its own 128-bit unique identifier. These bits are factory configured and cannot be changed by the user. The ERASE pin has no effect on the unique identifier.

## 9.1.3.8 User Signature

Each part contains a User Signature of 512 bytes. It can be used by the user to store user information such as trimming, keys, etc., that the customer does not want to be erased by asserting the ERASE pin or by software ERASE command. Read, write and erase of this area is allowed.

### 9.1.3.9 Fast Flash Programming Interface

The Fast Flash Programming Interface allows programming the device through a multiplexed fully-handshaked parallel port. It allows gang programming with market-standard industrial programmers.

The FFPI supports read, page program, page erase, full erase, lock, unlock and protect commands.

### 9.1.3.10 SAM-BA Boot

The SAM-BA Boot is a default Boot Program which provides an easy way to program in-situ the on-chip Flash memory.

The SAM-BA Boot Assistant supports serial communication via the UART and USB.

The SAM-BA Boot provides an interface with SAM-BA Graphic User Interface (GUI).

The SAM-BA Boot is in ROM and is mapped in Flash at address 0x0 when GPNVM bit 1 is set to 0.

### 9.1.3.11 GPNVM Bits

The SAM4S features two GPNVM bits. These bits can be cleared or set respectively through the commands "Clear GPNVM Bit" and "Set GPNVM Bit" of the EEFC User Interface.

The Flash of the SAM4S16/SA16 is composed of 1024 Kbytes in a single bank. The Flash of the SAM4S8 is composed of 512Kbytes in a single bank.

The SAM4SD32/SD16 features 3 GPNVM bits that can be cleared or set respectively through the "Clear GPNVM Bit" and "Set GPNVM Bit" commands of the EEFC User Interface. The GPNVM0 is the security bit. The GPNVM1 is used to select the boot mode (boot always at 0x00) on ROM or FLASH. The SAM4SD32/16 embeds an additional GPNVM bit: GPNVM2. This GPNVM bit is used only to swap the Flash0 and Flash1. If GPNVM bit 2 is:

ENABLE: the Flash1 is mapped at address 0x0040\_0000 (Flash1 and Flash0 are continuous).  
 DISABLE: the Flash0 is mapped at address 0x0040\_0000 (Flash0 and Flash1 are continuous).

**Table 9-2.** General-purpose Non volatile Memory Bits

GPNVMBit[#]	Function
0	Security bit
1	Boot mode selection
2	Flash selection (Flash 0 or Flash 1)

### 9.1.4 Boot Strategies

The system always boots at address 0x0. To ensure maximum boot possibilities, the memory layout can be changed via GPNVM.

A general purpose NVM (GPNVM) bit is used to boot either on the ROM (default) or from the Flash.

The GPNVM bit can be cleared or set respectively through the commands "Clear General-purpose NVM Bit" and "Set General-purpose NVM Bit" of the EEFC User Interface.

Setting GPNVM Bit 1 selects the boot from the Flash, clearing it selects the boot from the ROM. Asserting ERASE clears the GPNVM Bit 1 and thus selects the boot from the ROM by default.

Setting the GPNVM Bit 2 selects bank 1, clearing it selects the boot from bank 0. Asserting ERASE clears the GPNVM Bit 2 and thus selects the boot from bank 0 by default.

## 9.2 External Memories

The SAM4S features one External Bus Interface to provide an interface to a wide range of external memories and to any parallel peripheral.

### 9.2.1 Static Memory Controller

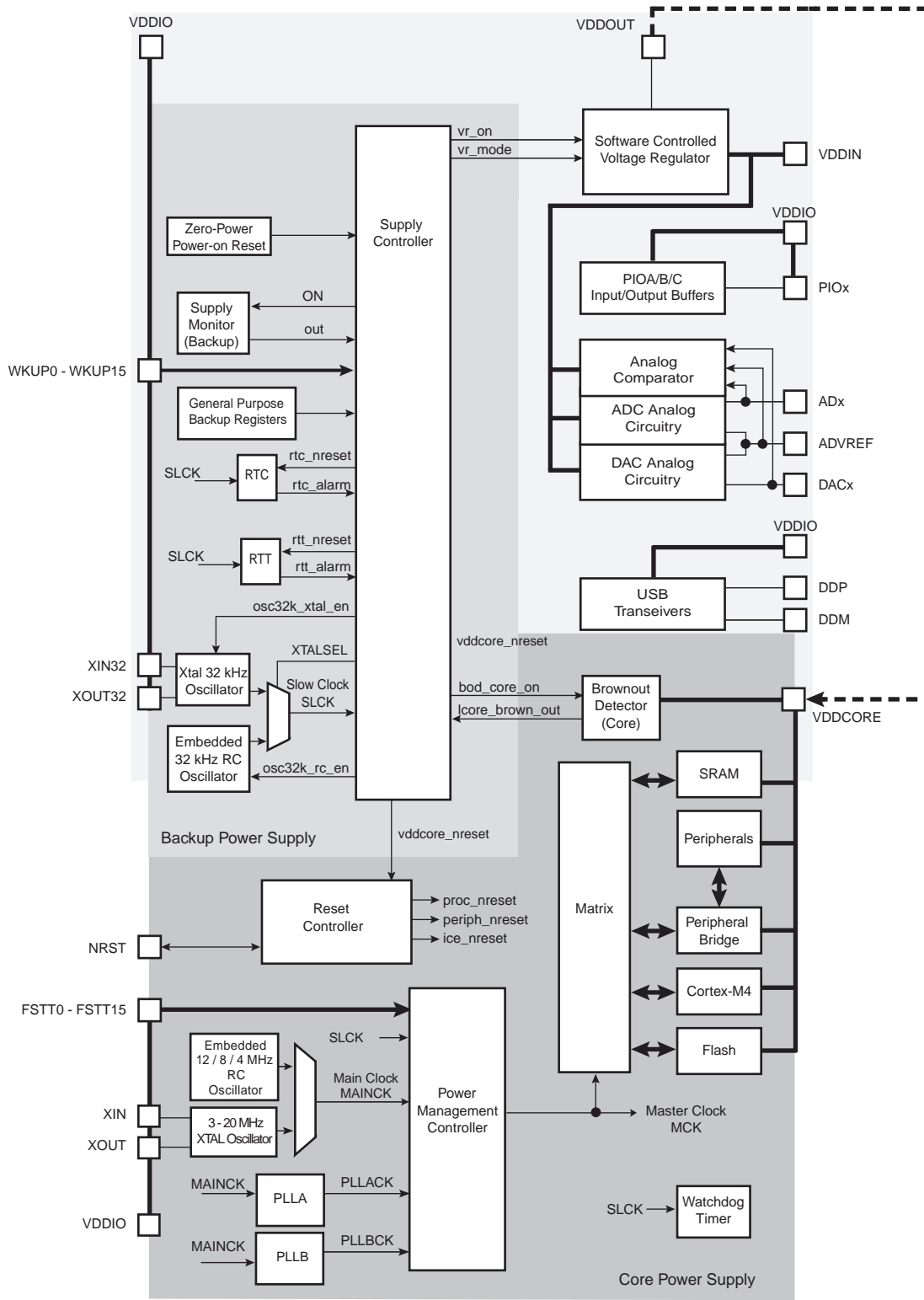
- 16-Mbyte Address Space per Chip Select
- 8-bit Data Bus
- Word, Halfword, Byte Transfers
- Programmable Setup, Pulse And Hold Time for Read Signals per Chip Select
- Programmable Setup, Pulse And Hold Time for Write Signals per Chip Select
- Programmable Data Float Time per Chip Select
- External Wait Request
- Automatic Switch to Slow Clock Mode
- Asynchronous Read in Page Mode Supported: Page Size Ranges from 4 to 32 Bytes
- NAND Flash additional logic supporting NAND Flash with Multiplexed Data/Address buses
- Hardware Configurable number of chip selects from 1 to 4
- Programmable timing on a per chip select basis

## 10. System Controller

The System Controller is a set of peripherals which allows handling of key elements of the system, such as power, resets, clocks, time, interrupts, watchdog, etc...

See the system controller block diagram in [Figure 10-1 on page 40](#).

Figure 10-1. System Controller Block Diagram



FSTT0 - FSTT15 are possible Fast Startup sources, generated by WKUP0 - WKUP15 pins, but are not physical pins.



## 10.1 System Controller and Peripheral Mapping

Refer to [Figure 8-1, "SAM4S Product Mapping"](#).

All the peripherals are in the bit band region and are mapped in the bit band alias region.

## 10.2 Power-on-Reset, Brownout and Supply Monitor

The SAM4S embeds three features to monitor, warn and/or reset the chip:

- Power-on-Reset on VDDIO
- Brownout Detector on VDDCORE
- Supply Monitor on VDDIO

### 10.2.1 Power-on-Reset

The Power-on-Reset monitors VDDIO. It is always activated and monitors voltage at start up but also during power down. If VDDIO goes below the threshold voltage, the entire chip is reset. For more information, refer to the “Electrical Characteristics” section of the datasheet.

### 10.2.2 Brownout Detector on VDDCORE

The Brownout Detector monitors VDDCORE. It is active by default. It can be deactivated by software through the Supply Controller (SUPC\_MR). It is especially recommended to disable it during low-power modes such as wait or sleep modes.

If VDDCORE goes below the threshold voltage, the reset of the core is asserted. For more information, refer to the “Supply Controller (SUPC)” and “Electrical Characteristics” sections of the datasheet.

### 10.2.3 Supply Monitor on VDDIO

The Supply Monitor monitors VDDIO. It is not active by default. It can be activated by software and is fully programmable with 16 steps for the threshold (between 1.6V to 3.4V). It is controlled by the Supply Controller (SUPC). A sample mode is possible. It allows to divide the supply monitor power consumption by a factor of up to 2048. For more information, refer to the “Supply Controller (SUPC)” and “Electrical Characteristics” sections of the datasheet.

## 10.3 Reset Controller

The Reset Controller is based on a Power-on-Reset cell, and a Supply Monitor on VDDCORE.

The Reset Controller is capable to return to the software the source of the last reset, either a general reset, a wake-up reset, a software reset, a user reset or a watchdog reset.

The Reset Controller controls the internal resets of the system and the NRST pin input/output. It is capable to shape a reset signal for the external devices, simplifying to a minimum connection of a push-button on the NRST pin to implement a manual reset.

The configuration of the Reset Controller is saved as supplied on VDDIO.

## 10.4 Supply Controller (SUPC)

The Supply Controller controls the power supplies of each section of the processor and the peripherals (via Voltage regulator control).

The Supply Controller has its own reset circuitry and is clocked by the 32 kHz Slow clock generator.

The reset circuitry is based on a zero-power power-on reset cell and a brownout detector cell. The zero-power power-on reset allows the Supply Controller to start properly, while the software-programmable brownout detector allows detection of either a battery discharge or main voltage loss.

The Slow Clock generator is based on a 32 kHz crystal oscillator and an embedded 32 kHz RC oscillator. The Slow Clock defaults to the RC oscillator, but the software can enable the crystal oscillator and select it as the Slow Clock source.

The Supply Controller starts up the device by sequentially enabling the internal power switches and the Voltage Regulator, then it generates the proper reset signals to the core power supply.

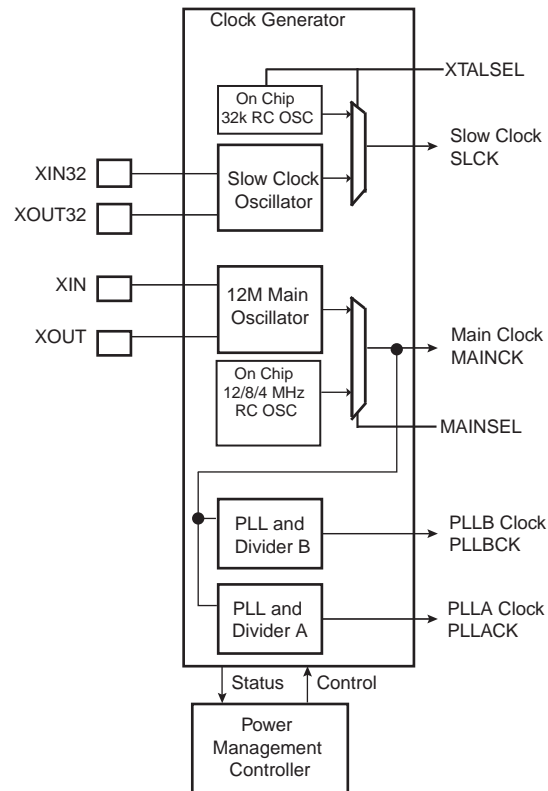
It also enables to set the system in different low-power modes and to wake it up from a wide range of events.

## 10.5 Clock Generator

The Clock Generator is made up of:

- One Low-power 32768 Hz Slow Clock Oscillator with bypass mode
- One Low-power RC Oscillator
- One 3-20 MHz Crystal Oscillator, which can be bypassed
- One Fast RC Oscillator, factory programmed. Three output frequencies can be selected: 4, 8 or 12 MHz. By default 4 MHz is selected.
- One 80 to 240 MHz PLL (PLL<sub>B</sub>) providing a clock for the USB Full Speed Controller
- One 80 to 240 MHz programmable PLL (PLL<sub>A</sub>), provides the clock, MCK to the processor and peripherals. The PLL<sub>A</sub> input frequency is from 3 MHz to 32 MHz.

**Figure 10-2.** Clock Generator Block Diagram



## 10.6 Power Management Controller

The Power Management Controller provides all the clock signals to the system. It provides:

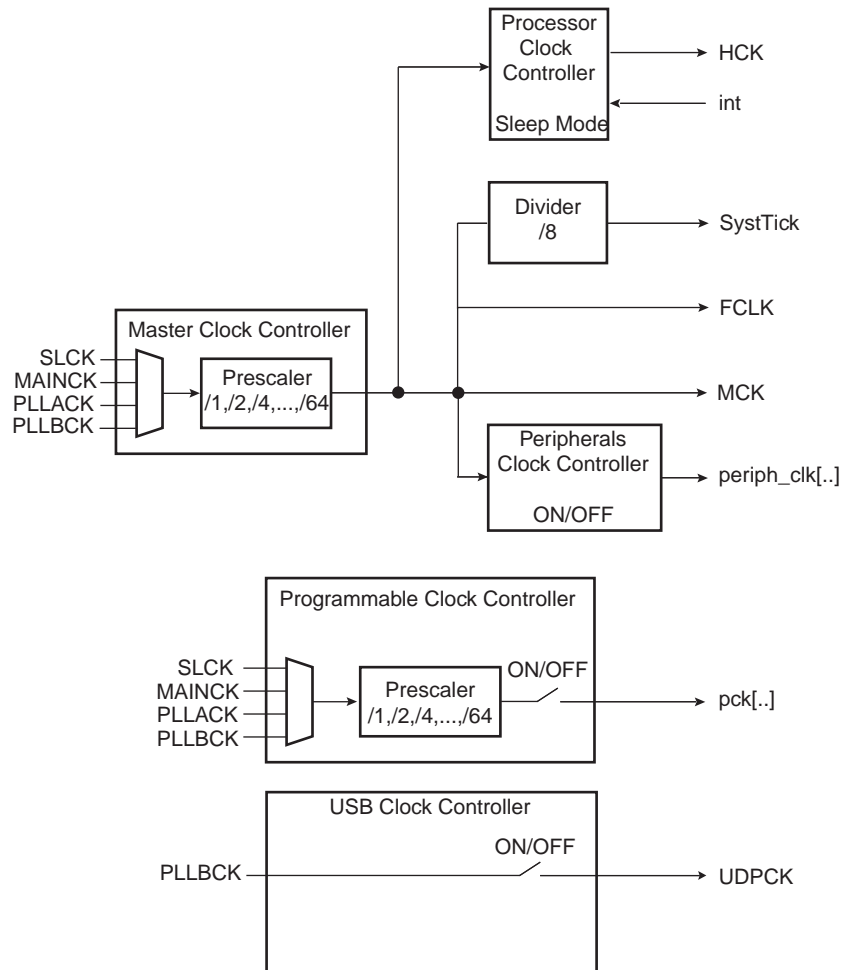
- the Processor Clock, HCLK
- the Free running processor clock, FCLK
- the Cortex SysTick external clock
- the Master Clock, MCK, in particular to the Matrix and the memory interfaces
- the USB Clock, UDPCK
- independent peripheral clocks, typically at the frequency of MCK
- three programmable clock outputs: PCK0, PCK1 and PCK2

The Supply Controller selects between the 32 kHz RC oscillator or the crystal oscillator. The unused oscillator is disabled automatically so that power consumption is optimized.

By default, at startup the chip runs out of the Master Clock using the fast RC oscillator running at 4 MHz.

The user can trim the 8 and 12 MHz RC Oscillator frequency by software.

**Figure 10-3.** Power Management Controller Block Diagram



The SysTick calibration value is fixed at 12500, which allows the generation of a time base of 1 ms with SysTick clock at 12.5 MHz (max HCLK/8 = 100 MHz/8 = 12500, so STCALIB = 0x30D4).

## 10.7 Watchdog Timer

- 16-bit key-protected only-once Programmable Counter
- Windowed, prevents the processor to be in a deadlock on the watchdog access

## 10.8 SysTick Timer

- 24-bit down counter
- Self-reload capability
- Flexible System timer

## 10.9 Real-Time Timer

- Real-Time Timer, allowing backup of time with different accuracies
  - 32-bit Free-running backup Counter
  - Integrates a 16-bit programmable prescaler running on slow clock
  - Alarm Register capable to generate a wake-up of the system through the Shut Down Controller

## 10.10 Real Time Clock

- Low power consumption
- Full asynchronous design
- Two hundred year Gregorian and Persian calendar
- Programmable Periodic Interrupt
- Trimmable 32.7682 kHz crystal oscillator clock source
- Alarm and update parallel load
- Control of alarm and update Time/Calendar Data In
- Waveform output capability on GPIO pins in low power modes

## 10.11 General-Purpose Backup Registers

- Eight 32-bit backup general-purpose registers

## 10.12 Nested Vectored Interrupt Controller

- Thirty maskable external interrupts
- Sixteen priority levels
- Processor state automatically saved on interrupt entry, and restored on
- Dynamic reprioritizing of interrupts
- Priority grouping.
  - selection of pre-empting interrupt levels and non pre-empting interrupt levels.
- Support for tail-chaining and late arrival of interrupts.
  - back-to-back interrupt processing without the overhead of state saving and restoration between interrupts.
- Processor state automatically saved on interrupt entry, and restored on interrupt exit, with no instruction overhead.

## 10.13 Chip Identification

- Chip Identifier (CHIPID) registers permit recognition of the device and its revision.

**Table 10-1.** SAM4S Chip IDs Register

Chip Name	Flash Size (Kbytes)	RAM Size (Kbytes)	Pin Count	CHIPID_CIDR	CHIPID_EXID
SAM4SD32C	2*1024	160	100	0X29A7_0EE0	
SAM4SD32B	2*1024	160	64	0X2997_0EE0	
SAM4SD16C	2*512	160	100	0X29A7_0CE0	
SAM4SD16B	2*512	160	64	0X2997_0CE0	
SAM4SA16C	1024	160	100	0X28A7_0CE0	0x0
SAM4SA16B	1024	160	64	0X2897_0CE0	0x0
SAM4S16B	1024	128	64	0x289C_0CE0	0x0
SAM4S16C	1024	128	100	0x28AC_0CE0	0x0
SAM4S8B	512	128	64	0x289C_0AE0	0x0
SAM4S8C	512	128	100	0x28AC_0AE0	0x0

- JTAG ID: 05B3\_203F

## 10.14 PIO Controllers

- 3 PIO Controllers, PIOA, PIOB and PIOC (100-pin version only) controlling a maximum of 79 I/O Lines
- Each PIO Controller controls up to 32 programmable I/O Lines
- Fully programmable through Set/Clear Registers

**Table 10-2.** PIO available according to pin count

Version	64 pin	100 pin
PIOA	32	32
PIOB	15	15
PIOC	-	32

- Multiplexing of four peripheral functions per I/O Line
- For each I/O Line (whether assigned to a peripheral or used as general purpose I/O)
  - Input change interrupt
  - Programmable Glitch filter
  - Programmable debouncing filter
  - Multi-drive option enables driving in open drain
  - Programmable pull-up on each I/O line
  - Pin data status register, supplies visibility of the level on the pin at any time
  - Additional interrupt modes on a programmable event: rising edge, falling edge, low level or high level
  - Lock of the configuration by the connected peripheral
- Synchronous output, provides set and clear of several I/O lines in a single write

- Write Protect Registers
- Programmable Schmitt trigger inputs
- Parallel capture mode
  - Can be used to interface a CMOS digital image sensor, an ADC....
  - One clock, 8-bit parallel data and two data enable on I/O lines
  - Data can be sampled one time out of two (for chrominance sampling only)
  - Supports connection of one Peripheral DMA Controller channel (PDC) which offers buffer reception without processor intervention

## 10.15 Peripheral Identifiers

Table 10-3 defines the Peripheral Identifiers of the SAM4S. A peripheral identifier is required for the control of the peripheral interrupt with the Nested Vectored Interrupt Controller and control of the peripheral clock with the Power Management Controller.

**Table 10-3.** Peripheral Identifiers

Instance ID	Instance Name	NVIC Interrupt	PMC Clock Control	Instance Description
0	SUPC	X		Supply Controller
1	RSTC	X		Reset Controller
2	RTC	X		Real Time Clock
3	RTT	X		Real Time Timer
4	WDT	X		Watchdog Timer
5	PMC	X		Power Management Controller
6	EEFC0	X		Enhanced Embedded Flash Controller 0
7	EEFC1	-		Enhanced Embedded Flash Controller 1
8	UART0	X	X	UART 0
9	UART1	X	X	UART 1
10	SMC	X	X	Static Memory Controller
11	PIOA	X	X	Parallel I/O Controller A
12	PIOB	X	X	Parallel I/O Controller B
13	PIOC	X	X	Parallel I/O Controller C
14	USART0	X	X	USART 0
15	USART1	X	X	USART 1
16	-	-	-	Reserved
17	-	-	-	Reserved
18	HSMCI	X	X	Multimedia Card Interface
19	TWI0	X	X	Two Wire Interface 0
20	TWI1	X	X	Two Wire Interface 1
21	SPI	X	X	Serial Peripheral Interface
22	SSC	X	X	Synchronous Serial Controller
23	TC0	X	X	Timer/Counter 0

**Table 10-3.** Peripheral Identifiers (Continued)

Instance ID	Instance Name	NVIC Interrupt	PMC Clock Control	Instance Description
24	TC1	X	X	Timer/Counter 1
25	TC2	X	X	Timer/Counter 2
26	TC3	X	X	Timer/Counter 3
27	TC4	X	X	Timer/Counter 4
28	TC5	X	X	Timer/Counter 5
29	ADC	X	X	Analog To Digital Converter
30	DACC	X	X	Digital To Analog Converter
31	PWM	X	X	Pulse Width Modulation
32	CRCCU	X	X	CRC Calculation Unit
33	ACC	X	X	Analog Comparator
34	UDP	X	X	USB Device Port

### 10.16 Peripheral Signal Multiplexing on I/O Lines

The SAM4S features 2 PIO controllers on 64-pin version (PIOA and PIOB) or 3 PIO controllers on the 100-pin version (PIOA, PIOB and PIOC), that multiplex the I/O lines of the peripheral set.

The SAM4S 64-pin and 100-pin PIO Controllers control up to 32 lines. Each line can be assigned to one of three peripheral functions: A, B or C. The multiplexing tables in the following paragraphs define how the I/O lines of the peripherals A, B and C are multiplexed on the PIO Controllers. The column “Comments” has been inserted in this table for the user’s own comments; it may be used to track how pins are defined in an application.

Note that some peripheral functions which are output only, might be duplicated within the tables.



## 10.16.1 PIO Controller A Multiplexing

**Table 10-4.** Multiplexing on PIO Controller A (PIOA)

I/O Line	Peripheral A	Peripheral B	Peripheral C	Extra Function	System Function	Comments
PA0	PWMH0	TIOA0	A17	WKUP0		
PA1	PWMH1	TIOB0	A18	WKUP1		
PA2	PWMH2	SCK0	DATRG	WKUP2		
PA3	TWD0	NPCS3				
PA4	TWCK0	TCLK0		WKUP3		
PA5	RXD0	NPCS3		WKUP4		
PA6	TXD0	PCK0				
PA7	RTS0	PWMH3			XIN32	
PA8	CTS0	ADTRG		WKUP5	XOUT32	
PA9	URXD0	NPCS1	PWMF10	WKUP6		
PA10	UTXD0	NPCS2				
PA11	NPCS0	PWMH0		WKUP7		
PA12	MISO	PWMH1				
PA13	MOSI	PWMH2				
PA14	SPCK	PWMH3		WKUP8		
PA15	TF	TIOA1	PWML3	WKUP14/PIODCEN1		
PA16	TK	TIOB1	PWML2	WKUP15/PIODCEN2		
PA17	TD	PCK1	PWMH3	AD0		
PA18	RD	PCK2	A14	AD1		
PA19	RK	PWML0	A15	AD2/WKUP9		
PA20	RF	PWML1	A16	AD3/WKUP10		
PA21	RXD1	PCK1		AD8		64/100 pins versions
PA22	TXD1	NPCS3	NCS2	AD9		64/100 pins versions
PA23	SCK1	PWMH0	A19	PIODCCLK		64/100 pins versions
PA24	RTS1	PWMH1	A20	PIODC0		64/100 pins versions
PA25	CTS1	PWMH2	A23	PIODC1		64/100 pins versions
PA26	DCD1	TIOA2	MCDA2	PIODC2		64/100 pins versions
PA27	DTR1	TIOB2	MCDA3	PIODC3		64/100 pins versions
PA28	DSR1	TCLK1	MCCDA	PIODC4		64/100 pins versions
PA29	RI1	TCLK2	MCCK	PIODC5		64/100 pins versions
PA30	PWML2	NPCS2	MCDA0	WKUP11/PIODC6		64/100 pins versions
PA31	NPCS1	PCK2	MCDA1	PIODC7		64/100 pins versions

## 10.16.2 PIO Controller B Multiplexing

**Table 10-5.** Multiplexing on PIO Controller B (PIOB)

I/O Line	Peripheral A	Peripheral B	Peripheral C	Extra Function	System Function	Comments
PB0	PWMH0			AD4/RTCOUT0		
PB1	PWMH1			AD5/RTCOUT1		
PB2	URXD1	NPCS2		AD6/WKUP12		
PB3	UTXD1	PCK2		AD7		
PB4	TWD1	PWMH2			TDI	
PB5	TWCK1	PWML0		WKUP13	TDO/TRACESWO	
PB6					TMS/SWDIO	
PB7					TCK/SWCLK	
PB8					XOUT	
PB9					XIN	
PB10					DDM	
PB11					DDP	
PB12	PWML1				ERASE	
PB13	PWML2	PCK0		DAC0		64/00 pins versions
PB14	NPCS1	PWMH3		DAC1		64/100 pins versions

## 10.16.3 PIO Controller C Multiplexing.

**Table 10-6.** Multiplexing on PIO Controller C (PIOC)

I/O Line	Peripheral A	Peripheral B	Peripheral C	Extra Function	System Function	Comments
PC0	D0	PWML0				100 pin version
PC1	D1	PWML1				100 pin version
PC2	D2	PWML2				100 pin version
PC3	D3	PWML3				100 pin version
PC4	D4	NPCS1				100 pin version
PC5	D5					100 pin version
PC6	D6					100 pin version
PC7	D7					100 pin version
PC8	NWE					100 pin version
PC9	NANDOE					100 pin version
PC10	NANDWE					100 pin version
PC11	NRD					100 pin version
PC12	NCS3			AD12		100 pin version
PC13	NWAIT	PWML0		AD10		100 pin version
PC14	NCS0					100 pin version
PC15	NCS1	PWML1		AD11		100 pin version
PC16	A21/NANDALE					100 pin version
PC17	A22/NANDCLE					100 pin version
PC18	A0	PWMH0				100 pin version
PC19	A1	PWMH1				100 pin version
PC20	A2	PWMH2				100 pin version
PC21	A3	PWMH3				100 pin version
PC22	A4	PWML3				100 pin version
PC23	A5	TIOA3				100 pin version
PC24	A6	TIOB3				100 pin version
PC25	A7	TCLK3				100 pin version
PC26	A8	TIOA4				100 pin version
PC27	A9	TIOB4				100 pin version
PC28	A10	TCLK4				100 pin version
PC29	A11	TIOA5		AD13		100 pin version
PC30	A12	TIOB5		AD14		100 pin version
PC31	A13	TCLK5				100 pin version

## 11. Embedded Peripherals Overview

### 11.1 Serial Peripheral Interface (SPI)

- Supports communication with serial external devices
  - Four chip selects with external decoder support allow communication with up to 15 peripherals
  - Serial memories, such as DataFlash® and 3-wire EEPROMs
  - Serial peripherals, such as ADCs, DACs, LCD Controllers, CAN Controllers and Sensors
  - External co-processors
- Master or slave serial peripheral bus interface
  - 8- to 16-bit programmable data length per chip select
  - Programmable phase and polarity per chip select
  - Programmable transfer delays between consecutive transfers and between clock and data per chip select
  - Programmable delay between consecutive transfers
  - Selectable mode fault detection
- Connection to PDC channel capabilities optimizes data transfers
  - One channel for the receiver, one channel for the transmitter
  - Next buffer support

### 11.2 Two Wire Interface (TWI)

- Master, Multi-Master and Slave Mode Operation
- Compatibility with Atmel two-wire interface, serial memory and I<sup>2</sup>C compatible devices
- One, two or three bytes for slave address
- Sequential read/write operations
- Bit Rate: Up to 400 kbit/s
- General Call Supported in Slave Mode
- Connecting to PDC channel capabilities optimizes data transfers in Master Mode only
  - One channel for the receiver, one channel for the transmitter
  - Next buffer support

### 11.3 Universal Asynchronous Receiver Transceiver (UART)

- Two-pin UART
  - Independent receiver and transmitter with a common programmable Baud Rate Generator
  - Even, Odd, Mark or Space Parity Generation
  - Parity, Framing and Overrun Error Detection
  - Automatic Echo, Local Loopback and Remote Loopback Channel Modes
  - Support for two PDC channels with connection to receiver and transmitter

## 11.4 USART

- Programmable Baud Rate Generator
- 5- to 9-bit full-duplex synchronous or asynchronous serial communications
  - 1, 1.5 or 2 stop bits in Asynchronous Mode or 1 or 2 stop bits in Synchronous Mode
  - Parity generation and error detection
  - Framing error detection, overrun error detection
  - MSB- or LSB-first
  - Optional break generation and detection
  - By 8 or by-16 over-sampling receiver frequency
  - Hardware handshaking RTS-CTS
  - Receiver time-out and transmitter timeguard
  - Optional Multi-drop Mode with address generation and detection
  - Optional Manchester Encoding
  - Full modem line support on USART1 (DCD-DSR-DTR-RI)
- RS485 with driver control signal
- ISO7816, T = 0 or T = 1 Protocols for interfacing with smart cards
  - NACK handling, error counter with repetition and iteration limit
- SPI Mode
  - Master or Slave
  - Serial Clock programmable Phase and Polarity
  - SPI Serial Clock (SCK) Frequency up to MCK/4
- IrDA modulation and demodulation
  - Communication at up to 115.2 Kbps
- Test Modes
  - Remote Loopback, Local Loopback, Automatic Echo

## 11.5 Synchronous Serial Controller (SSC)

- Provides serial synchronous communication links used in audio and telecom applications (with CODECs in Master or Slave Modes, I<sup>2</sup>S, TDM Buses, Magnetic Card Reader)
- Contains an independent receiver and transmitter and a common clock divider
- Offers configurable frame sync and data length
- Receiver and transmitter can be programmed to start automatically or on detection of different event on the frame sync signal
- Receiver and transmitter include a data signal, a clock signal and a frame synchronization signal

## 11.6 Timer Counter (TC)

- Six 16-bit Timer Counter Channels
- Wide range of functions including:
  - Frequency Measurement
  - Event Counting

- Interval Measurement
- Pulse Generation
- Delay Timing
- Pulse Width Modulation
- Up/down Capabilities
- Each channel is user-configurable and contains:
  - Three external clock inputs
  - Five internal clock inputs
  - Two multi-purpose input/output signals
- Two global registers that act on all three TC Channels
- Quadrature decoder
  - Advanced line filtering
  - Position / revolution / speed
- 2-bit Gray Up/Down Counter for Stepper Motor

## 11.7 Pulse Width Modulation Controller (PWM)

- One Four-channel 16-bit PWM Controller, 16-bit counter per channel
- Common clock generator, providing Thirteen Different Clocks
  - A Modulo n counter providing eleven clocks
  - Two independent Linear Dividers working on modulo n counter outputs
  - High Frequency Asynchronous clocking mode
- Independent channel programming
  - Independent Enable Disable Commands
  - Independent Clock Selection
  - Independent Period and Duty Cycle, with Double Buffering
  - Programmable selection of the output waveform polarity
  - Programmable center or left aligned output waveform
  - Independent Output Override for each channel
  - Independent complementary Outputs with 12-bit dead time generator for each channel
  - Independent Enable Disable Commands
  - Independent Clock Selection
  - Independent Period and Duty Cycle, with Double Buffering
- Synchronous Channel mode
  - Synchronous Channels share the same counter
  - Mode to update the synchronous channels registers after a programmable number of periods
- Connection to one PDC channel
  - Provides Buffer transfer without processor intervention, to update duty cycle of synchronous channels
- Two independent event lines which can send up to 4 triggers on ADC within a period

- One programmable Fault Input providing an asynchronous protection of outputs
- Stepper motor control (2 Channels)

## 11.8 High Speed Multimedia Card Interface (HSMCI)

- 4-bit or 1-bit Interface
- Compatibility with MultiMedia Card Specification Version 4.3
- Compatibility with SD and SDHC Memory Card Specification Version 2.0
- Compatibility with SDIO Specification Version V1.1.
- Compatibility with CE-ATA Specification 1.1
- Cards clock rate up to Master Clock divided by 2
- Boot Operation Mode support
- High Speed mode support
- Embedded power management to slow down clock rate when not used
- MCI has one slot supporting
  - One MultiMediaCard bus (up to 30 cards) or
  - One SD Memory Card
  - One SDIO Card
- Support for stream, block and multi-block data read and write

## 11.9 USB Device Port (UDP)

- USB V2.0 full-speed compliant, 12 Mbits per second.
- Embedded USB V2.0 full-speed transceiver
- Embedded 2688-byte dual-port RAM for endpoints
- Eight endpoints
  - Endpoint 0: 64bytes
  - Endpoint 1 and 2: 64 bytes ping-pong
  - Endpoint 3: 64 bytes
  - Endpoint 4 and 5: 512 bytes ping-pong
  - Endpoint 6 and 7: 64 bytes ping-pong
  - Ping-pong Mode (two memory banks) for Isochronous and bulk endpoints
- Suspend/resume logic
- Integrated Pull-up on DDP
- Pull-down resistor on DDM and DDP when disabled

## 11.10 Analog-to-Digital Converter (ADC12B)

- up to 16 Channels, 12-bit ADC
- 10/12-bit resolution
- up to 1 MSample/s
- Programmable conversion sequence conversion on each channel
- Integrated temperature sensor
- Automatic calibration mode

- Single ended/differential conversion
- Programmable gain: 1, 2, 4

### 11.11 Digital-to-Analog Converter (DAC)

- Up to 2 channel 12-bit DAC
- Up to 2 mega-samples conversion rate in single channel mode
- Flexible conversion range
- Multiple trigger sources for each channel
- 2 Sample/Hold (S/H) outputs
- Built-in offset and gain calibration
- Possible to drive output to ground
- Possible to use as input to analog comparator or ADC (as an internal wire and without S/H stage)
- Two PDC channels
- Power reduction mode

### 11.12 Static Memory Controller

- 16-Mbyte Address Space per Chip Select
- 8-bit Data Bus
- Word, Halfword, Byte Transfers
- Byte Write or Byte Select Lines
- Programmable Setup, Pulse And Hold Time for Read Signals per Chip Select
- Programmable Setup, Pulse And Hold Time for Write Signals per Chip Select
- Programmable Data Float Time per Chip Select
- Compliant with LCD Module
- External Wait Request
- Automatic Switch to Slow Clock Mode
- Asynchronous Read in Page Mode Supported: Page Size Ranges from 4 to 32 Bytes
- NAND Flash additional logic supporting NAND Flash with Multiplexed Data/Address buses
- Hardware Configurable number of chip select from 1 to 4
- Programmable timing on a per chip select basis

### 11.13 Analog Comparator

- One analog comparator
- High speed option vs. low-power option
  - 170  $\mu$ A/xx ns active current consumption/propagation delay
  - 20  $\mu$ A/xx ns active current consumption/propagation delay
- Selectable input hysteresis
  - 0, 15 mV, 30mV (Typ)
- Minus input selection:
  - DAC outputs



- Temperature Sensor
- ADVREF
- AD0 to AD3 ADC channels
- Plus input selection:
  - All analog inputs
- output selection:
  - Internal signal
  - external pin
  - selectable inverter
- window function
- Interrupt on:
  - Rising edge, Falling edge, toggle
  - Signal above/below window, signal inside/outside window

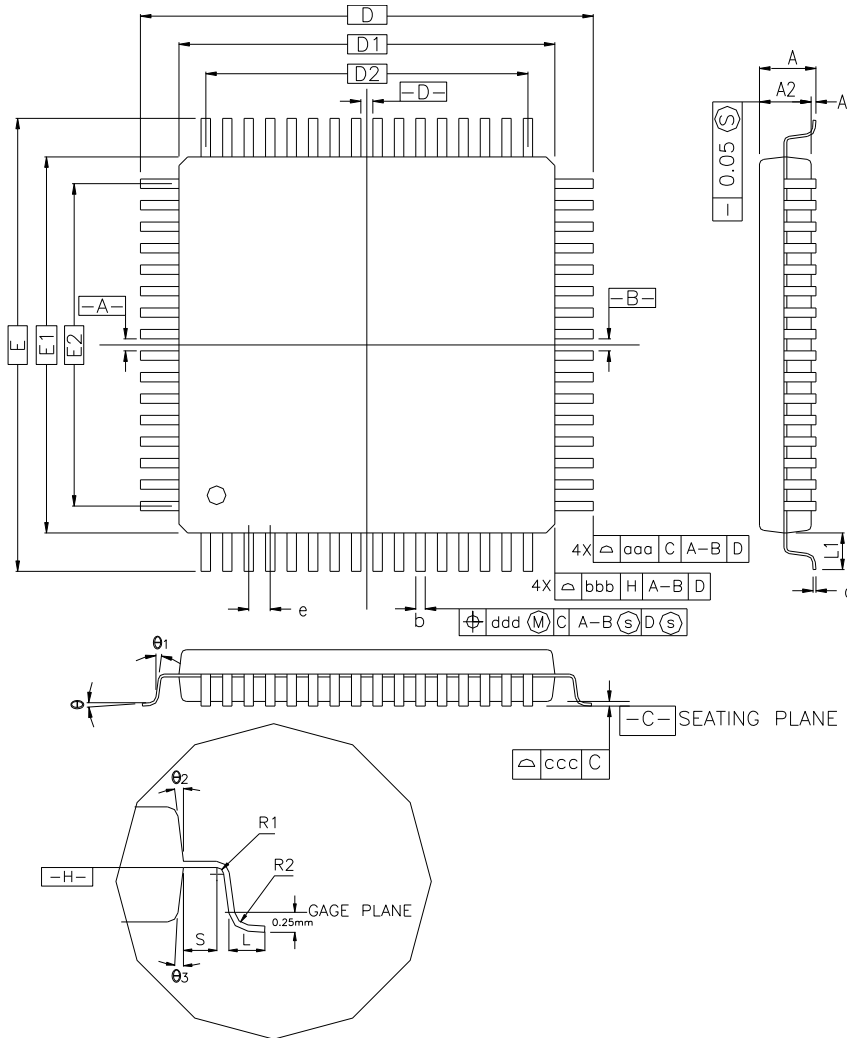
## 11.14 Cyclic Redundancy Check Calculation Unit (CRCCU)

- 32-bit cyclic redundancy check automatic calculation
- CRC calculation between two addresses of the memory

## 12. Package Drawings

The SAM4S series devices are available in LQFP, QFN, TFBGA and VFBGA packages.

Figure 12-1. 100-lead LQFP Package Mechanical Drawing

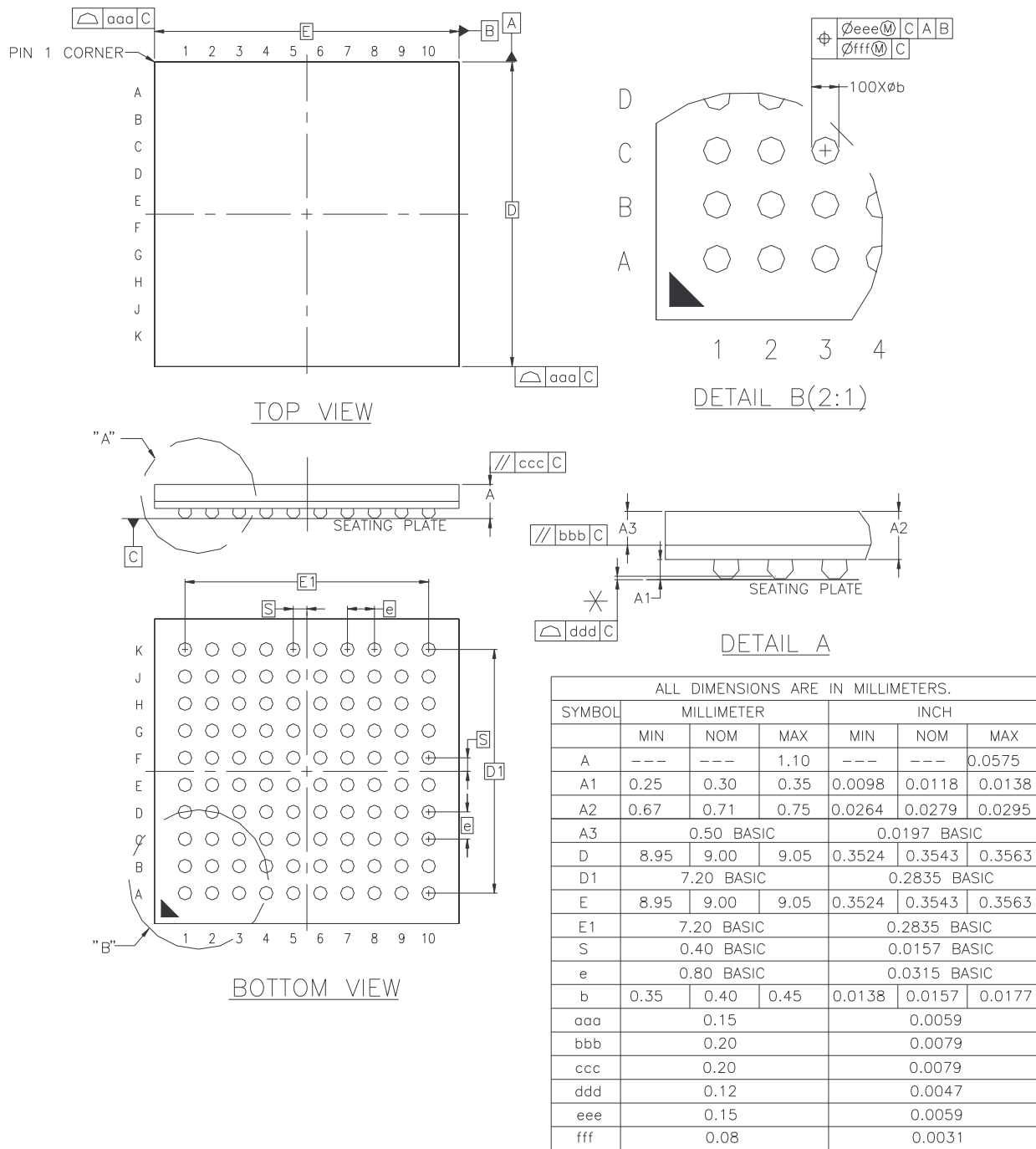


CONTROL DIMENSIONS ARE IN MILLIMETERS.

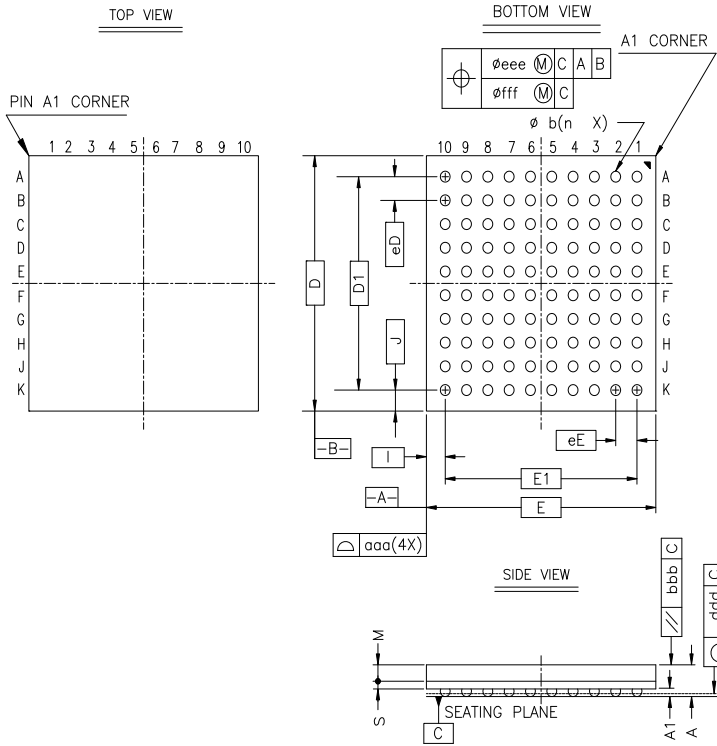
SYMBOL	MILLIMETER			INCH		
	MIN.	NOM.	MAX.	MIN.	NOM.	MAX.
A	—	—	1.60	—	—	0.063
A1	0.05	—	0.15	0.002	—	0.006
A2	1.35	1.40	1.45	0.053	0.055	0.057
D	16.00 BSC.			0.630 BSC.		
D1	14.00 BSC.			0.551 BSC.		
E	16.00 BSC.			0.630 BSC.		
E1	14.00 BSC.			0.551 BSC.		
R2	0.08	—	0.20	0.003	—	0.008
R1	0.08	—	—	0.003	—	—
$\theta$	0°	3.5°	7°	0°	3.5°	7°
$\theta_1$	0°	—	—	0°	—	—
$\theta_2$	11°	12°	13°	11°	12°	13°
$\theta_3$	11°	12°	13°	11°	12°	13°
c	0.09	—	0.20	0.004	—	0.008
L	0.45	0.60	0.75	0.018	0.024	0.030
L <sub>1</sub>	1.00 REF			0.039 REF		
S	0.20	—	—	0.008	—	—
b	0.17	0.20	0.27	0.007	0.008	0.011
e	0.50 BSC.			0.020 BSC.		
D2	12.00			0.472		
E2	12.00			0.472		
TOLERANCES OF FORM AND POSITION						
aaa	0.20			0.008		
bbb	0.20			0.008		
ccc	0.08			0.003		
ddd	0.08			0.003		

Note : 1. This drawing is for general information only. Refer to JEDEC Drawing MS-026 for additional information.

**Figure 12-2. 100-ball TFBGA Package Mechanical Drawing**

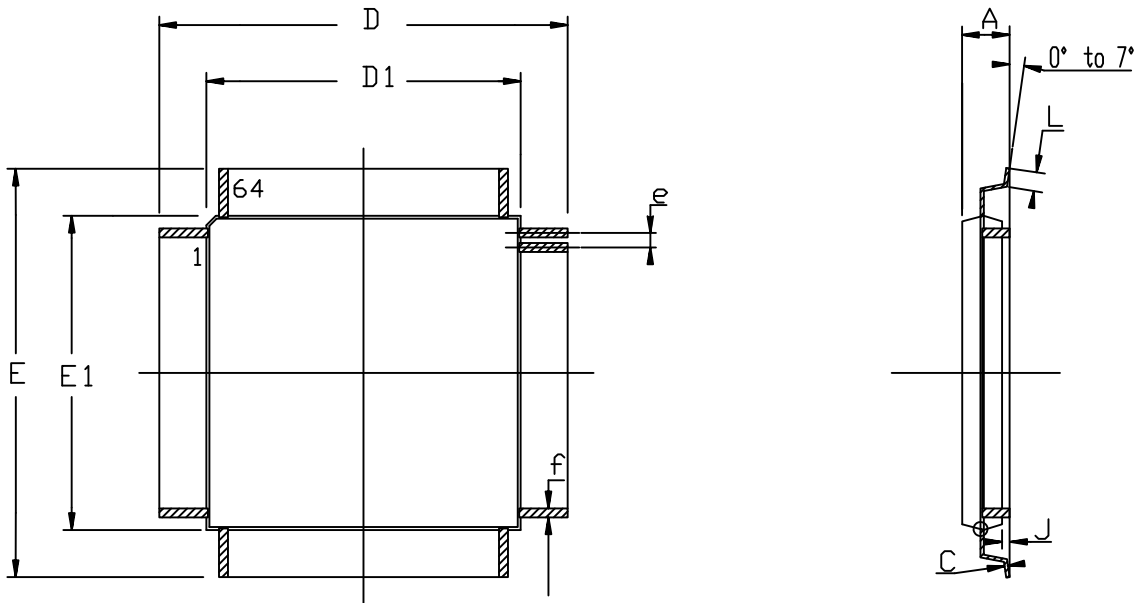


**Figure 12-3. 100-ball VFBGA Package Drawing**



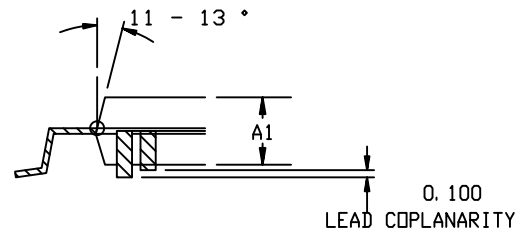
	Symbol	Common Dimensions
Package :		VFBGA
Body Size:	X	E 7.000±0.100
	Y	D 7.000±0.100
Ball Pitch :	X	eE 0.650
	Y	eD 0.650
Total Thickness :	A	1.000 MAX
Mold Thickness :	M	0.450 Ref.
Substrate Thickness :	s	0.210 Ref.
Ball Diameter :		0.300
Stand Off :	A1	0.160 ~ 0.260
Ball Width :	b	0.270 ~ 0.370
Package Edge Tolerance :	aaa	0.100
Mold Flatness :	bbb	0.100
Coplanarity:	ddd	0.080
Ball Offset (Package) :	eee	0.150
Ball Offset (Ball) :	fff	0.080
Ball Count :	n	100
Edge Ball Center to Center :	X	E1 5.850
	Y	D1 5.850
Corner Ball Center to Package Edge:	X	I 0.575
	Y	J 0.575

Figure 12-4. 64-lead LQFP Package Mechanical Drawing

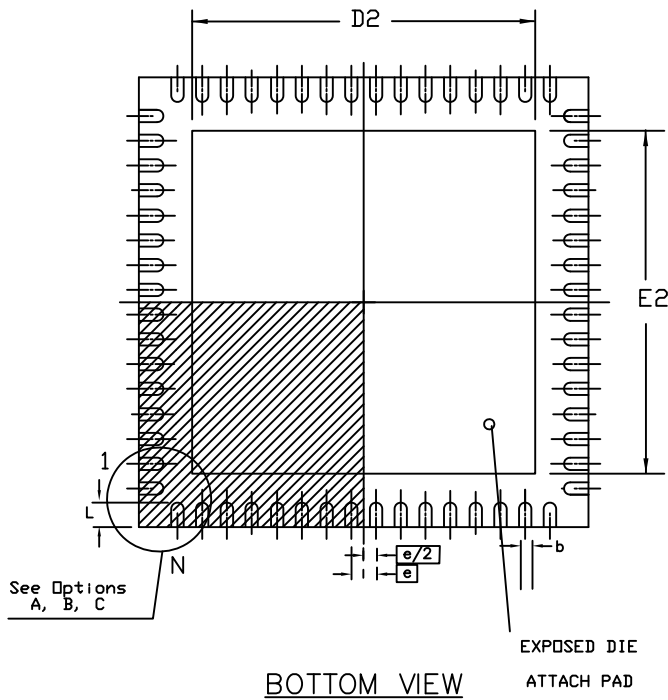
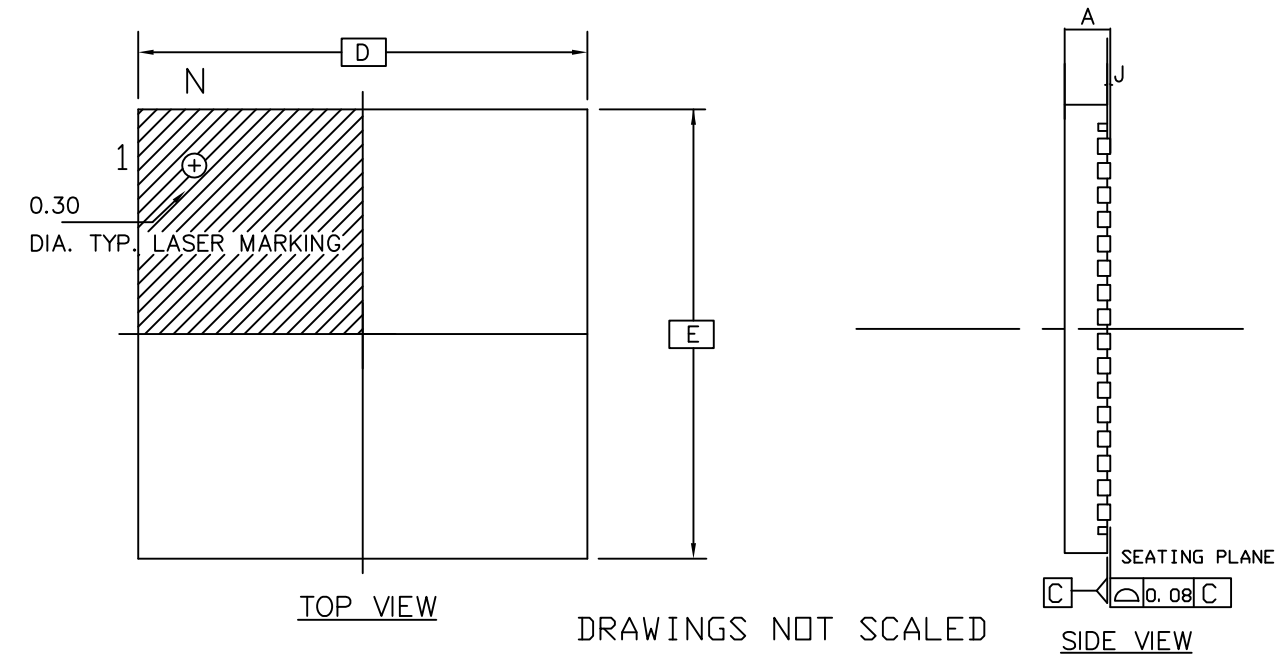


COMMON DIMENSIONS IN MM

SYMBOL	Min	Max	NOTES
A	----	1.20	
A1	0.95	1.05	
C	0.09	0.20	
D	16.00 BSC		
D1	14.00 BSC		
E	16.00 BSC		
E1	14.00 BSC		
J	0.05	0.15	
L	0.45	0.75	
e	0.80 BSC		
f	0.30	0.45	

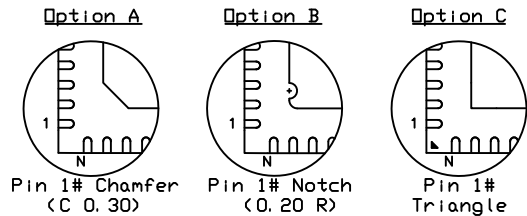


**Figure 12-5.** 64-lead QFN Package Mechanical Drawing



COMMON DIMENSIONS IN MM

SYMBOL	MIN.	NOM.	MAX.	NOTES
A	0.80	----	1.00	
J	0.00	----	0.05	
D/E	9.00 BSC			
D2/E2	3.25	----	7.50	
N	64			
e	0.50 BSC			
L	0.30	0.40	0.55	
b	0.18	0.25	0.30	



## 13. Ordering Information

**Table 13-1.** Ordering Codes for SAM4S Devices

Ordering Code	MRL	Flash (Kbytes)	Package	Package Type	Temperature Operating Range
ATSAM4SD32CA-CU	A	2*1024	TFBGA100	Green	Industrial (-40°C to +85°C)
ATSAM4SD32CA-CFU	A	2*1024	VFBGA100	Green	Industrial (-40°C to +85°C)
ATSAM4SD32CA-AU	A	2*1024	LQFP100	Green	Industrial (-40°C to +85°C)
ATSAM4SD32BA-MU	A	2*1024	QFN64	Green	Industrial (-40°C to +85°C)
ATSAM4SD32BA-AU	A	2*1024	LQFP64	Green	Industrial (-40°C to +85°C)
ATSAM4SD16CA-CU	A	2*512	TFBGA100	Green	Industrial (-40°C to +85°C)
ATSAM4SD16CA-CFU	A	2*512	VFBGA100	Green	Industrial (-40°C to +85°C)
ATSAM4SD16CA-AU	A	2*512	LQFP100	Green	Industrial (-40°C to +85°C)
ATSAM4SD16BA-MU	A	2*512	QFN64	Green	Industrial (-40°C to +85°C)
ATSAM4SD16BA-AU	A	2*512	LQFP64	Green	Industrial (-40°C to +85°C)
ATSAM4SA16CA-CU	A	1024	TFBGA100	Green	Industrial (-40°C to +85°C)
ATSAM4SA16CA-CFU	A	1024	VFBGA100	Green	Industrial (-40°C to +85°C)
ATSAM4SA16CA-AU	A	1024	LQFP100	Green	Industrial (-40°C to +85°C)
ATSAM4SA16BA-MU	A	1024	QFN64	Green	Industrial (-40°C to +85°C)
ATSAM4SA16BA-AU	A	1024	LQFP64	Green	Industrial (-40°C to +85°C)
ATSAM4S16CA-CU	A	1024	TFBGA100	Green	Industrial (-40°C to +85°C)
ATSAM4S16CA-CFU	A	1024	VFBGA100	Green	Industrial (-40°C to +85°C)
ATSAM4S16CA-AU	A	1024	LQFP100	Green	Industrial (-40°C to +85°C)
ATSAM4S16BA-MU	A	1024	QFN64	Green	Industrial (-40°C to +85°C)
ATSAM4S16BA-AU	A	1024	LQFP64	Green	Industrial (-40°C to +85°C)

**Table 13-1.** Ordering Codes for SAM4S Devices

Ordering Code	MRL	Flash (Kbytes)	Package	Package Type	Temperature Operating Range
ATSAM4S8CA-CU	A	512	TFBGA100	Green	Industrial (-40°C to +85°C)
ATSAM4S8CA-CFU	A	512	VFBGA100	Green	Industrial (-40°C to +85°C)
ATSAM4S8CA-AU	A	512	LQFP100	Green	Industrial (-40°C to +85°C)
ATSAM4S8BA-MU	A	512	QFN64	Green	Industrial (-40°C to +85°C)
ATSAM4S8BA-AU	A	512	LQFP64	Green	Industrial (-40°C to +85°C)







Doc. Rev 11100AS	Comments	Change Request Ref.
	Initial release.	





## Headquarters

### **Atmel Corporation**

2325 Orchard Parkway  
San Jose, CA 95131  
USA  
Tel: (+1) (408) 441-0311  
Fax: (+1) (408) 487-2600

## International

### **Atmel Asia Limited**

Unit 01-5 & 16, 19F  
BEA Tower, Millennium City 5  
418 Kwun Tong Road  
Kwun Tong, Kowloon  
HONG KONG  
Tel: (+852) 2245-6100  
Fax: (+852) 2722-1369

### **Atmel Munich GmbH**

Business Campus  
Parking 4  
D-85748 Garching b. Munich  
GERMANY  
Tel: (+49) 89-31970-0  
Fax: (+49) 89-3194621

### **Atmel Japan**

9F, Tonetsu Shinkawa Bldg.  
1-24-8 Shinkawa  
Chuo-ku, Tokyo 104-0033  
JAPAN  
Tel: (81) 3-3523-3551  
Fax: (81) 3-3523-7581

## Product Contact

### **Web Site**

[www.atmel.com](http://www.atmel.com)  
[www.atmel.com/AT91SAM](http://www.atmel.com/AT91SAM)

### **Technical Support**

AT91SAM Support  
Atmel technical support

### **Sales Contacts**

[www.atmel.com/contacts/](http://www.atmel.com/contacts/)

### **Literature Requests**

[www.atmel.com/literature](http://www.atmel.com/literature)

**Disclaimer:** The information in this document is provided in connection with Atmel products. No license, express or implied, by estoppel or otherwise, to any intellectual property right is granted by this document or in connection with the sale of Atmel products. **EXCEPT AS SET FORTH IN ATMEL'S TERMS AND CONDITIONS OF SALE LOCATED ON ATMEL'S WEB SITE, ATMEL ASSUMES NO LIABILITY WHATSOEVER AND DISCLAIMS ANY EXPRESS, IMPLIED OR STATUTORY WARRANTY RELATING TO ITS PRODUCTS INCLUDING, BUT NOT LIMITED TO, THE IMPLIED WARRANTY OF MERCHANTABILITY, FITNESS FOR A PARTICULAR PURPOSE, OR NON-INFRINGEMENT. IN NO EVENT SHALL ATMEL BE LIABLE FOR ANY DIRECT, INDIRECT, CONSEQUENTIAL, PUNITIVE, SPECIAL OR INCIDENTAL DAMAGES (INCLUDING, WITHOUT LIMITATION, DAMAGES FOR LOSS OF PROFITS, BUSINESS INTERRUPTION, OR LOSS OF INFORMATION) ARISING OUT OF THE USE OR INABILITY TO USE THIS DOCUMENT, EVEN IF ATMEL HAS BEEN ADVISED OF THE POSSIBILITY OF SUCH DAMAGES.** Atmel makes no representations or warranties with respect to the accuracy or completeness of the contents of this document and reserves the right to make changes to specifications and product descriptions at any time without notice. Atmel does not make any commitment to update the information contained herein. Unless specifically provided otherwise, Atmel products are not suitable for, and shall not be used in, automotive applications. Atmel's products are not intended, authorized, or warranted for use as components in applications intended to support or sustain life.



© 2012 Atmel Corporation. All rights reserved. Atmel®, Atmel logo and combinations thereof, QTouch®, DataFlash®, SAM-BA® and others are registered trademarks or trademarks of Atmel Corporation or its subsidiaries. Windows® and others, are registered trademarks or trademarks of Microsoft Corporation in the US and/or other countries. ARM®, ARM®Powered logo, Cortex®, Thumb®-2 and others are registered trademarks or trademarks of ARM Ltd. Other terms and product names may be trademarks of others.