

16-bit Proprietary Microcontroller

CMOS

F²MC-16F MB90210 Series

MB90214/P214A/P214B/W214A/W214B/V210

■ OUTLINE

The MB90210 series is a line of 16-bit microcontrollers particularly suitable for system control of video cameras, VTRs, and copiers. The F²MC-16F CPU integrated in this series is based on the F²MC*-16, while providing enhanced instructions for high-level languages and supporting extended addressing modes.

The MB90210 series incorporates a variety of peripheral resources such as a PWC timer with 4 channels, a 10-bit A/D converter with 8 channels, UART serial ports with 3 channels (1 channel for CTS and 1 channel for dual input/output pin switching), 16-bit reload timers with 8 channels, and an 8-bit PPG timer with 1 channel.

MB90P214B/W214B is under development.

*: F²MC stands for FUJITSU Flexible Microcontroller.

■ PACKAGE

80-pin Plastic QFP

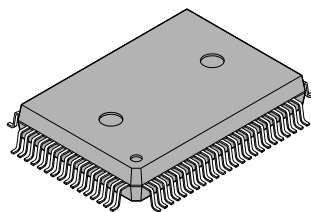

(FPT-80P-M06)

80-pin Ceramic QFP

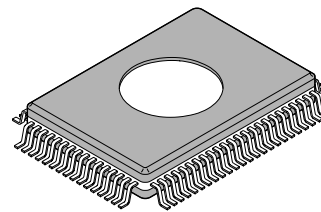

(FPT-80C-C02)

MB90210 Series

■ FEATURES

F²MC-16F CPU

- Minimum execution time: 62.5 ns/16-MHz oscillation (using a duty control system)
- Instruction sets optimized for controllers
 - Upward object-compatible with the F²MC-16(H)
 - Various data types (bit, byte, word, and long-word)
 - Instruction cycle improved to speed up operation
 - Extended addressing modes: 25 types
 - High coding efficiency
 - Access method (bank access with linear pointer)
 - Enhanced multiplication and division instructions (with signed instructions added)
 - Higher-precision operation using a 32-bit accumulator
- Extended intelligent I/O service (Automatic transfer function independent of instructions) access area expanded to 64 Kbytes
- Enhanced instruction set applicable to high-level language (C) and multitasking
 - System stack pointer
 - Enhanced pointer-indirect instructions
 - Barrel shift instruction
 - Stack check function
- Increased execution speed: 8-byte instruction queue
- Powerful interrupt functions: 8 levels and 29 sources

Integrated Peripheral Resources

- ROM : 64 Kbytes (MB90214)
 - EPROM : 64 Kbytes (MB90W214A/W214B)
 - OTPROM: 64Kbytes (MB90P214A/P214B)
- RAM: 3 Kbytes (MB90214)
 - 4 Kbytes (MB90P214A/P214B/W214A/W214B/V210)
- General-purpose ports: max. 65 channels
- PWC timer with time measurement function: 4 channels
- 10-bit A/D converter: 8 channels
- UART: 3 channels
- Including: 1 channel with CTS function
 - 1 channel with I/O pin switching function
- 16-bit reload timer
 - Toggled output, external clock, and gate functions: 4 channels
 - External clock and gate functions: 4 channels
- 8-bit PPG timer: 1 channel
- DTP/External-interrupt inputs: 4 channels
- Write-inhibit RAM: 256 bytes (MB90V210: 512 bytes)
- Timebase counter: 18 bits
- Clock gear function
- Low-power consumption mode
 - Sleep mode
 - Stop mode
 - Hardware standby mode

Product Description

- MB90214 is a mask ROM product.
- MB90P214A/P214B are OTPROM products.
- MB90W214A/W214B are EPROM products. ES only.
- Operating temperature of MB90P214A/W214A is -40°C to $+85^{\circ}\text{C}$. (However, the AC characteristics is assured in -40°C to $+70^{\circ}\text{C}$)
- MB90V210 is a evaluation device for the program development. ES only.

MB90210 Series

■ PRODUCT LINEUP

Part number Item	MB90214	MB90P214A MB90P214B	MB90W214A MB90W214B	MB90V210
Classification	Mask ROM product	OTPROM product	EPROM product	For evaluation
ROM size	64 Kbytes	64 Kbytes	64 Kbytes	—
RAM size	3 Kbytes	4 Kbytes	4 Kbytes	4 Kbytes
CPU functions	The number of instructions: 412 Instruction bit length: 8 or 16 bits Instruction length: 1 to 7 bytes Data bit length: 1, 4, 8, 16, or 32 bits Minimum execution time: 62.5 ns/16 MHz Interrupt processing time: 1.0 μs/16 MHz (min.)			
Ports	I/O ports (N-ch open-drain): 8 I/O ports (CMOS): 57 Total: 65			
PWC timer	Number of channels: 4 16-bit reload timer operation (operating clock cycle: 0.25 μs to 1.31 ms) 16-bit pulse-width count operation (Allowing continuous/one-shot measurement, H/L width measurement, inter-edge measurement, and divided-frequency measurement)			
10-bit A/D converter	Resolution: 10 or 8 bits, Number of inputs: 8 Single conversion mode (conversion for each input channel) Scan conversion mode (continuous conversion for up to 8 consecutive channels) Continuous conversion mode (repeated conversion for a selected channel) Stop conversion mode (conversion every fixed cycle)			
UART	Number of channels: 3 (1 channel with CTS function; 1 channel with I/O pin switching function) Clock-synchronous transfer mode (full-duplex double buffering, 7- to 9-bit data length, 2400 to 62500 bps) Asynchronous transfer mode (full-duplex double buffering, 7- to 9-bit data length, 2400 to 62500 bps)			
Timer	Number of channels: 4 channels × 2 types 16-bit reload timer operation (operating clock cycle: 0.25 μs to 1.05 s)			
8-bit PPG timer	Number of channels: 1 8-bit PPG operation (operating clock cycle: 0.25 μs to 6 s)			
DTP/External interrupt	Number of inputs: 4 External interrupt mode (allowing interrupts to activate at four different request levels) Simple DMA start mode (allowing extended I ² O/S to activate at two different request levels)			
Write-inhibit RAM	RAM size: 256 bytes (MB90V210: 512 bytes) RAM write-protectable with \overline{WI} pin			
Standby mode	Stop mode (activated by software or hardware) and sleep mode			
Gear function	Machine clock operating frequency switching: 16, 8, 4, or 1 MHz (at 16 MHz oscillation)			
Package	FPT-80P-M06		FPT-80C-C02	PGA-256C-A02

MB90210 Series

■ DIFFERENCES BETWEEN MB90214 (MASK ROM PRODUCT) AND MB90P214A/P214B/W214A/W214B

Part number Item	MB90214	MB90P214A MB90P214B	MB90W214A MB90W214B
ROM	Mask ROM 64 Kbytes	OTPROM 64 Kbytes	EPROM 64 Kbytes
Pin function 43 pins	MD2 pin	MD2/V _{PP} pin	

Note: MB90V210, device used for evaluation, is not warranted for electrical specifications.

MB90210 Series

PIN ASSIGNMENT

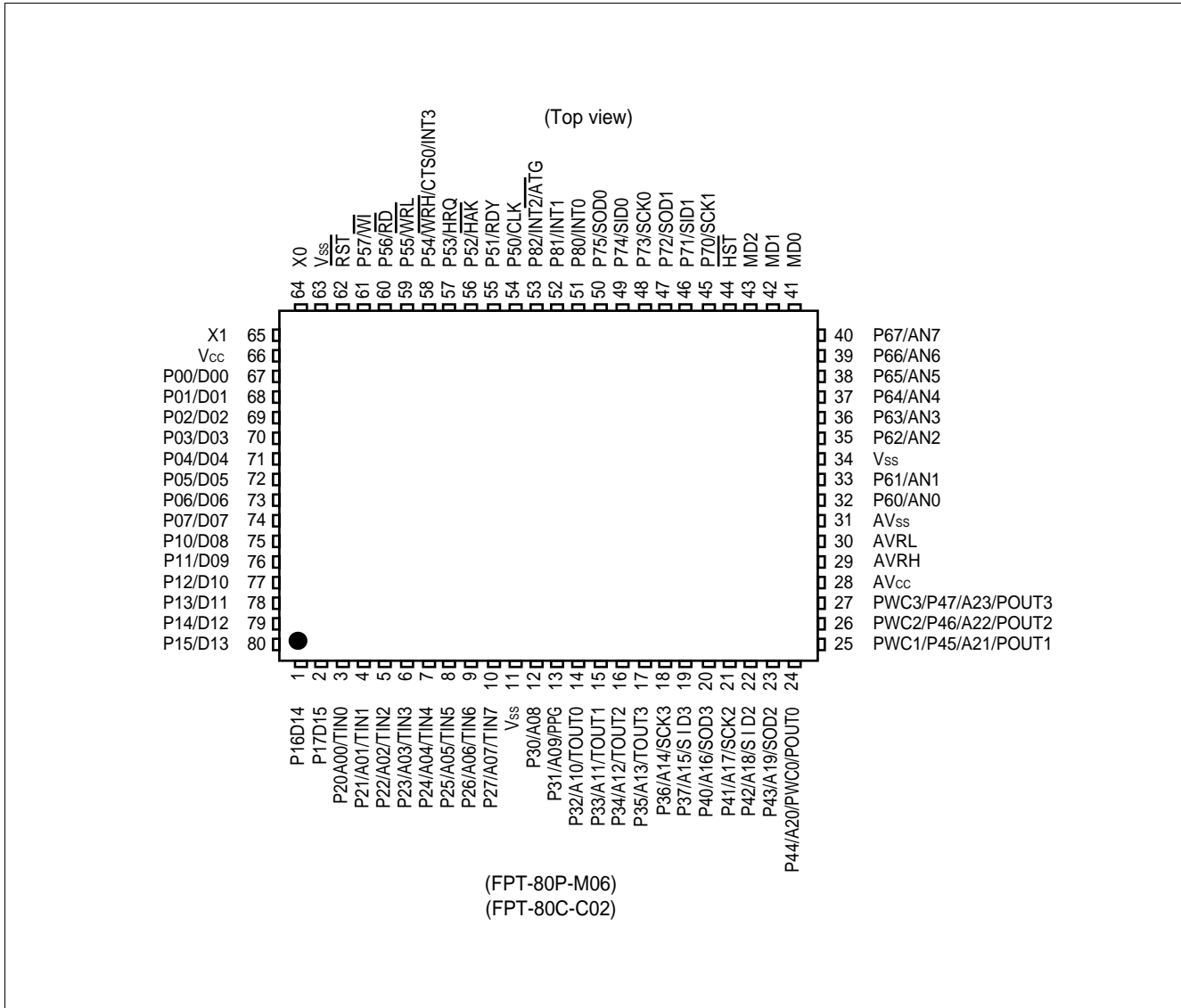

■ PIN DESCRIPTION

Pin no. QFP*	Pin name	Circuit type	Function
64, 65	X0, X1	A	Crystal oscillator pins (16 MHz)
62	\overline{RST}	H	External reset request input pin
66	V _{cc}	Power supply	Digital circuit power supply pin
11, 34, 63	V _{ss}	Power supply	Digital circuit grounding level
67 to 74	P00 to P07	B	General-purpose I/O ports These ports are available only in the single-chip mode.
	D00 to D07		I/O pins for the lower eight bits of external data bus These pins are available in an external-bus mode.
75 to 80, 1, 2	P10 to P15, P16, P17	B	General-purpose I/O ports These ports are available in the single-chip mode and in an external-bus mode with the 8-bit data bus specified.
	D08 to D13, D14, D15		I/O pins for the upper eight bits of external data bus These pins are available in an external-bus mode with the 16-bit data bus specified.
3 to 6	P20 to P23	E	General-purpose I/O ports These ports are available only in the single-chip mode.
	A00 to A03		Output pins for external address buses A00 to A03 These pins are available in an external-bus mode.
	TIN0 to TIN3		16-bit reload timer 1 (ch.0 to ch.3) input pins These pins are available when the 16-bit reload timer 1 (ch.0 to ch.3) input specification is "enabled". The data on the pin is read as the 16-bit reload timer 1 (ch.0 to ch.3) input (TIN0 to TIN3).
7 to 10	P24 to P27	E	General-purpose I/O ports These ports are available only in the single-chip mode.
	A04 to A07		Output pins for external address buses A04 to A07 These pins are available in an external-bus mode.
	TIN4 to TIN7		16-bit reload timer 2 (ch.4 to ch.7) input pins These pins are available when the 16-bit reload timer 2 (ch.4 to ch.7) input specification is "enabled". The data on the pin is read as the 16-bit reload timer 2 (ch.4 to ch.7) input (TIN4 to TIN7).
12	P30	E	General-purpose I/O port This port is available in the single-chip mode or when the middle address control register setting is "port."
	A08		Output pin for external address bus A08 This pin is available in an external-bus mode and when the middle address control register set to "address."

* : FPT-80P-M06, FPT-80C-C02

(Continued)

MB90210 Series

Pin no. QFP*	Pin name	Circuit type	Function
13	P31	E	General-purpose I/O port This port is available in the single-chip mode or when the middle address control register setting is "port", with the 8-bit PPG output is disabled.
	A09		Output pin for external address bus A09 This pin is available in an external-bus mode and when the middle address control register setting is "address."
	PPG		PPG timer output pin This pin is available when the PPG operation mode control register specification is the PPG output pin.
14 to 17	P32 to P35	E	General-purpose I/O ports These ports are available in the single-chip mode or when the middle address control register setting is "port", with the 16-bit reload timer 1 (ch.0 to ch.3) output is disabled.
	A10 to A13		Output pins for external address buses A10 to A13 These pins are available in an external-bus mode and when the middle address control register setting is "address."
	TOUT0 to TOUT3		16-bit reload timer 1 (ch.0 to ch.3) output pin These pins are available when the 16-bit reload timer 1 (ch.0 to ch.3) is output operation.
18	P36	E	General-purpose I/O port This port is available when the UART (ch.2) clock output is disabled either in the single-chip mode or when the middle address control register setting is "port."
	A14		Output pin for external address bus A14 This pin is available when the UART (ch.2) clock output is disabled in an external-bus mode and when the middle address control register setting is "address."
	SCK3		UART (ch.2) clock output pin (SCK3) This pin is available when the UART (ch.2) clock output is enabled. UART (ch.2) external clock input pin (SCK3) This pin is available when the port is in input mode and the UART (ch.2) specification is external clock mode.
19	P37	E	General-purpose I/O port This port is available in the single-chip mode or when the middle address control register setting is "port."
	A15		Output pin for external address bus A15 This pin is available in an external-bus mode and when middle address control register setting is "address."
	SID3		UART (ch.2) serial data input pin (SID3) Since this input is used whenever the SID3 is in input operation, the output by any other function must be suspended unless the output is intentionally performed.

* : FPT-80P-M06, FPT-80C-C02

(Continued)

MB90210 Series

Pin no. QFP*	Pin name	Circuit type	Function
20	P40	E	General-purpose I/O port This port is available when the UART (ch.2) serial data output from SOD3 is disabled either in the single-chip mode or when the upper address control register setting is "port."
	A16		Output pin for external address bus A16 This pin is available when the UART (ch.2) serial data output from SOD3 is disabled in an external-bus mode and when the upper address control register setting is "address."
	SOD3		UART (ch.2) serial data output pin (SOD3) This pin is available when the UART (ch.2) serial data output is enabled.
21	P41	E	General-purpose I/O port This port is available when the UART (ch.2) clock output is disabled either in the single-chip mode or when the upper address control register setting is "port."
	A17		Output pin for external address bus A17 This pin is available when the UART (ch.2) clock output is disabled in an external-bus mode and when the upper address control register setting is "address."
	SCK2		UART (ch.2) clock output pin (SCK2) This pin is available when the UART (ch.2) clock output is enabled. UART (ch.2) external clock input pin (SCK2) This pin is available when the port is in input mode and the UART (ch.2) specification is external clock mode.
22	P42	E	General-purpose I/O port This port is available in the single-chip mode or when the upper address control register setting is "port."
	A18		Output pin for external address bus A18 This pin is available in an external-bus mode and when the upper address control register setting is "address."
	SID2		UART (ch.2) serial data input pin (SID2) Since this input is used whenever the SID2 is in input operation, the output by any other function must be suspended unless the output is intentionally performed.
23	P43	E	General-purpose I/O port This port is available when the UART (ch.2) serial data output from SOD2 is disabled either in the single-chip mode or when the upper address control register setting is "port."
	A19		Output pin for external address bus A19 This pin is available when the UART (ch.2) serial data output from SOD2 is disabled in an external-bus mode and when the upper address control register setting is "address."
	SOD2		UART (ch.2) serial data output pin (SOD2) This pin is available when the UART (ch.2) serial data output from SOD2 is enabled.

* : FPT-80P-M06, FPT-80C-C02

(Continued)

MB90210 Series

Pin no. QFP*	Pin name	Circuit type	Function
24	PWC0	E	PWC timer input pin Since this input is used whenever the PWC0 timer is in input operation, the output by any other function must be suspended unless the output is intentionally performed.
	POUT0		PWC timer output pin This pin is available when the PWC0 is output operation.
25	P45	E	General-purpose I/O port This port is available in the single-chip mode or when the upper address control register setting is "port."
	A21		Output pin for external address bus A21 This pin is available in an external-bus mode and when the upper address control register setting is "address."
	PWC1		PWC timer data sample input pin Since this input is used whenever the PWC1 timer is in input operation, the output by any other function must be suspended unless the output is intentionally performed.
	POUT1		PWC timer output pin This pin is available when the PWC1 is output operation.
26	P46	E	General-purpose I/O port This port is available in the single-chip mode or when the upper address control register setting is "port."
	A22		Output pin for external address bus A22 This pin is available in an external-bus mode and when the upper address control register setting is "address."
	PWC2		PWC timer input pin Since this input is used whenever the PWC2 timer is in input operation, the output by any other function must be suspended unless the output is intentionally performed.
	POUT2		PWC timer output pin This pin is available when the PWC2 is output operation.
27	P47	E	General-purpose I/O port This port is available in the single-chip mode or when the upper address control register setting is "port."
	A23		Output pin for external address bus A23 This pin is available in an external-bus mode and when the upper address control register setting is "address."
	PWC3		PWC timer input pin Since this input is used whenever the PWC3 timer is in input operation, the output by any other function must be suspended unless the output is intentionally performed.
	POUT3		PWC timer output pin This pin is available when the PWC3 is output operation.

* : FPT-80P-M06, FPT-80C-C02

(Continued)

MB90210 Series

Pin no. QFP*	Pin name	Circuit type	Function
54	P50	E	General-purpose I/O port This port is available in the single-chip mode and when the CLK output is disabled.
	CLK		CLK output pin This pin is available in an external-bus mode with the CLK output enabled.
55	P51	E	General-purpose I/O port This port is available in the single-chip mode or when the ready function is disabled.
	RDY		Ready signal input pin This pin is available in an external-bus mode and when the ready function is enabled.
56	P52	E	General-purpose I/O port This port is available in the single-chip mode or when the hold function is disabled.
	$\overline{\text{HAK}}$		Hold acknowledge output pin This pin is available in an external-bus mode and when the hold function is enabled.
57	P53	E	General-purpose I/O port This port is available in the single-chip mode or when the hold function is disabled in an external-bus mode.
	HRQ		Hold request input pin This pin is available in an external-bus mode and when the hold function is enabled. Since this input is used during this operation at any time, the output by any other function must be suspended unless the output is intentionally performed.
58	P54	D	General-purpose I/O port This port is available in the single-chip mode, in the external bus 8-bit mode, or when the $\overline{\text{WRH}}$ pin output is disabled. When these pins are open in input mode, through current may leak in stop mode/reset mode, be sure to fix these pins to V_{cc}/V_{ss} level to use these pins in input mode.
	CTS0		UART (ch.0) clear-to-send input pin Since this input is used whenever the UART (ch.0) CTS function is enabled, the output by any other function must be suspended unless the output is intentionally performed. When these pins are open in input mode, through current may leak in stop mode/reset mode, be sure to fix these pins to V_{cc}/V_{ss} level to use these pins in input mode.
	$\overline{\text{WRH}}$		Write strobe output pin for the upper eight bits of data bus This pin is available in the external bus 16-bit mode with the $\overline{\text{WRH}}$ pin output enabled in an external-bus mode.

* : FPT-80P-M06, FPT-80C-C02

(Continued)

MB90210 Series

Pin no. QFP*	Pin name	Circuit type	Function
58	INT3	D	External interrupt request input pin Since this input is used whenever external interrupts are enabled, the output by any other function must be suspended unless the output is intentionally performed. When these pins are open in input mode, through current may leak in stop mode/reset mode, be sure to fix these pins to V_{CC}/V_{SS} level to use these pins in input mode.
59	P55	E	General-purpose I/O port This port is available in the single-chip mode or when the \overline{WRL} pin output is disabled.
	\overline{WRL}		Write strobe output pin for the lower eight bits of data bus This pin is available in an external-bus mode and when the \overline{WRL} pin output is enabled.
60	P56	E	General-purpose I/O port This port is available in the single-chip mode.
	\overline{RD}		Data bus read strobe output pin This pin is available in an external-bus mode.
61	P57	D	General-purpose I/O port This port is always available. When these pins are open in input mode, through current may leak in stop mode/reset mode, be sure to fix these pins to V_{CC}/V_{SS} level to use these pins in input mode.
	\overline{WI}		RAM write disable request input Since this input is used during this operation at any time, the output by any other function must be suspended unless the output is intentionally performed. When these pins are open in input mode, through current may leak in stop mode/reset mode, be sure to fix these pins to V_{CC}/V_{SS} level to use these pins in input mode.
32, 33, 35 to 40	P60, P61, P62 to P67	C	Open-drain I/O ports These ports are available when the analog input enable register setting is "port."
	AN0, AN1, AN2 to AN7		10-bit A/D converter analog input pins These pins are available when the analog input enable register setting is "analog input."
41 to 43	MD0 to MD2	F	Operation mode select signal input pins Connect these pins directly to V_{CC} or V_{SS} .
44	\overline{HST}	G	Hardware standby input pin
45	P70	E	General-purpose I/O port This port is available when the UART (ch.1) clock output is disabled.

* : FPT-80P-M06, FPT-80C-C02

(Continued)

MB90210 Series

Pin no. QFP*	Pin name	Circuit type	Function
45	SCK1	E	<p>UART (ch.1) clock output pin This pin is available when the UART (ch.1) clock output is enabled.</p> <p>UART (ch.1) external clock input pin This pin is available when the port is in input mode and the UART (ch.1) specification is external clock mode.</p>
46	P71	E	<p>General-purpose I/O port This port is always available.</p>
	SID1		<p>UART (ch.1) serial data input pin Since this input is used whenever the UART (ch.1) is in input operation, the output by any other function must be suspended unless the output is intentionally performed.</p>
47	P72	E	<p>General-purpose I/O port This port is available when the UART (ch.1) serial data output is disabled.</p>
	SOD1		<p>UART (ch.1) serial data output pin This pin is available when the UART (ch.1) serial data output is enabled.</p>
48	P73	E	<p>General-purpose I/O port This port is available when the UART (ch.0) clock output is disabled.</p>
	SCK0		<p>UART (ch.0) clock output pin This pin is available when the UART (ch.0) clock output is enabled.</p> <p>UART (ch.0) external clock input pin This pin is available when the port is in input mode and the UART (ch.0) specification is external clock mode.</p>
49	P74	E	<p>General-purpose I/O port This port is always available.</p>
	SID0		<p>UART (ch.0) serial data input pin Since this input is used whenever the UART (ch.0) is in input operation, the output by any other function must be suspended unless the output is intentionally performed.</p>
50	P75	E	<p>General-purpose I/O port This port is available when the UART (ch.0) serial data output is disabled.</p>
	SOD0		<p>UART (ch.0) serial data output pin This pin is available when the UART (ch.0) serial data output is enabled.</p>
51, 52	P80, P81	D	<p>General-purpose I/O port This port is always available. When these pins are open in input mode, through current may leak in stop mode/reset mode, be sure to fix these pins to V_{CC}/V_{SS} level to use these pins in input mode.</p>

* : FPT-80P-M06, FPT-80C-C02

(Continued)

MB90210 Series

(Continued)

Pin no. QFP*	Pin name	Circuit type	Function
51, 52	INT0, INT1	D	External interrupt request input pin Since this input is used whenever external interrupts are enabled, the output by any other function must be suspended unless the output is intentionally performed. When these pins are open in input mode, through current may leak in stop mode/reset mode, be sure to fix these pins to V_{CC}/V_{SS} level to use these pins in input mode.
53	P82	D	General-purpose I/O port This port is always available. When these pins are open in input mode, through current may leak in stop mode/reset mode, be sure to fix these pins to V_{CC}/V_{SS} level to use these pins in input mode.
	INT2		External interrupt request input pin Since this input is used whenever external interrupts are enabled, the output by any other function must be suspended unless the output is intentionally performed. When these pins are open in input mode, through current may leak in stop mode/reset mode, be sure to fix these pins to V_{CC}/V_{SS} level to use these pins in input mode.
	\overline{ATG}		10-bit A/D converter trigger input pin When these pins are open in input mode, through current may leak in stop mode/reset mode, be sure to fix these pins to V_{CC}/V_{SS} level to use these pins in input mode.
28	AV_{CC}	Power supply	Analog circuit power supply pin This power supply must be turned on or off with a potential equal to or higher than AV_{CC} applied to V_{CC} . Be sure that $AV_{CC} = V_{CC}$ before use and during operation.
29	AV_{RH}	Power supply	Analog circuit reference voltage input pin This pins must be turned on or off with a potential equal to or higher than AV_{RH} applied to AV_{CC} .
30	AV_{RL}	Power supply	Analog circuit reference voltage input pin
31	AV_{SS}	Power supply	Analog circuit grounding level

* : FPT-80P-M06, FPT-80C-C02

■ I/O CIRCUIT TYPE

Type	Circuit	Remarks
A	<p>Standby control</p>	<ul style="list-style-type: none"> Oscillation feedback resistor: Approx. 1 MΩ MB90214 MB90P214B MB90W214B
	<p>Standby control</p>	<ul style="list-style-type: none"> Oscillation feedback resistor: Approx. 1 MΩ MB90P214A MB90W214A
B	<p>Standby control</p>	<ul style="list-style-type: none"> CMOS-level I/O Standby control provided MB90214: With or without pull-up/pull-down resistor optional MB90P214A/P214B: Without pull-up/pull-down resistor MB90W214A/W214B: Without pull-up/pull-down resistor
C	<p>A/D input</p>	<ul style="list-style-type: none"> N-ch open-drain output CMOS-level hysteresis input A/D control provided
D	<p>Digital input</p>	<ul style="list-style-type: none"> CMOS-level output CMOS-level hysteresis input Standby control not provided MB90214: With or without pull-up/pull-down resistor optional MB90P214A/P214B: Without pull-up/pull-down resistor MB90W214A/W214B: Without pull-up/pull-down resistor

(Continued)

MB90210 Series

(Continued)

Type	Circuit	Remarks
E		<ul style="list-style-type: none"> • CMOS-level output • CMOS-level hysteresis input Standby control provided MB90214: With or without pull-up/pull-down resistor optional MB90P214A/P214B: Without pull-up/pull-down resistor MB90W214A/W214B: Without pull-up/pull-down resistor
F		<ul style="list-style-type: none"> • CMOS-level input with no standby control Mask ROM products only: MD2: With pull-down resistor MD1: With pull-up resistor MD0: With pull-down resistor
		<ul style="list-style-type: none"> • CMOS-level input with no standby control MD2 of OTPROM products/EPROM products only
G		<ul style="list-style-type: none"> • CMOS-level hysteresis input Standby control not provided • With input analog filter (40 ns Typ.)
H		<ul style="list-style-type: none"> • CMOS-level hysteresis input Standby control not provided • With input analog filter (40 ns Typ.) • With pull-up resistor MB90214: With or without pull-up/pull-down resistor optional MB90P214A/W214A/P214B/W214B: With pull-up resistor



Note: The pull-up and pull-down resistors are always connected, regardless of the state.

■ HANDLING DEVICES

1. Preventing Latchup

CMOS ICs may cause latchup when a voltage higher than V_{CC} or lower than V_{SS} is applied to input or output pins, or when a voltage exceeding the rating is applied between V_{CC} and V_{SS} .

If latch-up occurs, the power supply current increases rapidly, sometimes resulting in thermal breakdown of the device. Use meticulous care not to let any voltage exceed the maximum rating.

Also, take care to prevent the analog power supply (AV_{CC} and AV_{RH}) and analog input from exceeding the digital power supply (V_{CC}) when the analog system power supply is turned on and off.

2. Treatment of Unused Input Pins

Leaving unused input pins open could cause malfunctions. They should be connected to a pull-up or pull-down resistor.

3. Treatment of Pins when A/D is not Used

Connect to be $AV_{CC} = AV_{RH} = V_{CC}$ and $AV_{SS} = AV_{RL} = V_{SS}$ even if the A/D converter is not in use.

4. Precautions when Using an External Clock

To reset the internal circuit properly by the Low-level input to the \overline{RST} pin, the "L" level input to the \overline{RST} pin must be maintained for at least five machine cycles. Pay attention to it if the chip uses external clock input.

5. V_{CC} and V_{SS} Pins

Apply equal potential to the V_{CC} and V_{SS} pins.

6. Supply Voltage Variation

The operation assurance range for the V_{CC} supply voltage is as given in the ratings. However, sudden changes in the supply voltage can cause misoperation, even if the voltage remains within the rated range. Therefore, it is important to supply a stable voltage to the IC. The recommended power supply control guidelines are that the commercial frequency (50 to 60 Hz) ripple variation (P-P value) on V_{CC} should be less than 10% of the standard V_{CC} value and that the transient rate of change during sudden changes, such as during power supply switching, should be less than 0.1 V/ms.

7. Notes on Using an External Clock

When using an external clock, drive the X0 pin as illustrated below. When an external clock is used, oscillation stabilization time is required even for power-on reset and wake-up from stop mode.

• Use of External Clock

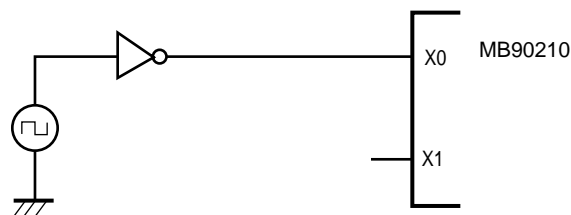

Note: When using an external clock, be sure to input external clock more than 6 machine cycles after setting the \overline{HST} pin to "L" to transfer to the hardware standby mode.

8. Power-on Sequence for A/D Converter Power Supplies and Analog Inputs

Be sure to turn on the digital power supply (V_{CC}) before applying voltage to the A/D converter power supplies (AV_{CC} , $AVRH$, and $AVRL$) and analog inputs ($AN0$ to $AN7$).

When turning power supplies off, turn off the A/D converter power supplies (AV_{CC} , $AVRH$, and $AVRL$) and analog inputs ($AN0$ to $AN7$) first, then the digital power supply (V_{CC}).

When turning $AVRH$ on or off, be careful not to let it exceed AV_{CC} .

■ PROGRAMMING FOR MB90P214A/P214B/W214A/W214B

In EPROM mode, the MB90P214A/P214B/W214A/W214B functions equivalent to the MBM27C1000. This allows the EPROM to be programmed with a general-purpose EPROM programmer by using the dedicated socket adapter (do not use the electronic signature mode).

1. Program Mode

When shipped from Fujitsu, and after each erasure, all bits (64 K × 8 bits) in the MB90P214A/P214B/W214A/W214B are in the “1” state. Data is written to the ROM by selectively programming “0’s” into the desired bit locations. Bits cannot be set to “1” electrically.

2. Programming Procedure

- (1) Set the EPROM programmer to MBM27C1000.
- (2) Load program data into the EPROM programmer at 10000_H to 1FFFF_H.

Note that ROM addresses FF0000_H to FFFFFFF_H in the operation mode in the MB90P214A/P214B/W214A/W214B series assign to 10000_H to 1FFFF_H in the EPROM mode (on the EPROM programmer).

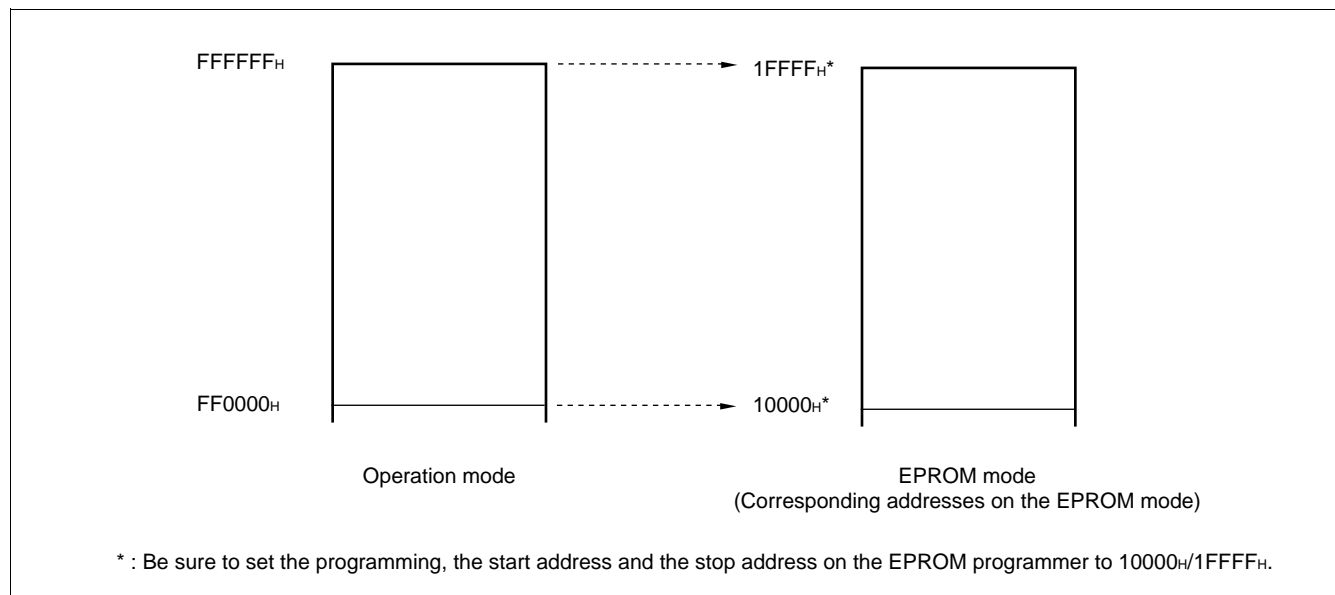

- (3) Mount the MB90P214A/P214B/W214A/W214B on the adapter socket, then fit the adapter socket onto the EPROM programmer. When mounting the device and the adapter socket, pay attention to their mounting orientations.
- (4) Start programming the program data to the device.
- (5) If programming has not successfully resulted, connect a capacitor of approx. 0.1 μF between V_{CC} and GND, between V_{PP} and GND.
- (6) Since the MB90P214A and MB90W214A have CMOS-level input, programming to them may be impossible depending on the output level of the general-purpose programmer. In that case, connect a pull-up resistor to the adapter socket side.

Note: The mask ROM products (MB90214) does not support EPROM mode. Data cannot, therefore, be read by the EPROM programmer.

MB90210 Series

3. EPROM Programmer Socket Adapter and Recommended Programmer Manufacturer

Part No.		MB90P214B	
Package		QFP-80	
Compatible socket adapter Sun Hayato Co., Ltd.		ROM-80QF-32DP-16F	
Recommended programmer manufacturer and programmer name	Advantest corp.	R4945A (main unit) + R49451A (adapter)	Recommended

Inquiry: Sun Hayato Co., Ltd.: TEL: (81)-3-3986-0403
FAX: (81)-3-5396-9106
Advantest Corp.: TEL: Except JAPAN (81)-3-3930-4111

4. Erase Procedure

Data written in the MB90W214A/W214B are erased (from "0" to "1") by exposing the chip to ultraviolet rays with a wavelength of 2,537 Å through the translucent cover.

Recommended irradiation dosage for exposure is 10 Wsec/cm². This amount is reached in 15 to 20 minutes with a commercial ultraviolet lamp positioned 2 to 3 cm above the package (when the package surface illuminance is 1200 μW/cm²).

If the ultraviolet lamp has a filter, remove the filter before exposure. Attaching a mirrored plate to the lamp increases the illuminance by a factor of 1.4 to 1.8, thus shortening the required erasure time. If the translucent part of the package is stained with oil or adhesive, transmission of ultraviolet rays is degraded, resulting in a longer erasure time. In that case, clean the translucent part using alcohol (or other solvent not affecting the package).

The above recommended dosage is a value which takes the guard band into consideration and is a multiple of the time in which all bits can be evaluated to have been erased. Observe the recommended dosage for erasure; the purpose of the guard band is to ensure erasure in all temperature and supply voltage ranges. In addition, check the life span of the lamp and control the illuminance appropriately.

Data in the MB90W214A/W214B are erased by exposure to light with a wavelength of 4000 Å or less.

Data in the device is also erased even by exposure to fluorescent lamp light or sunlight although the exposure results in a much lower erasure rate than exposure to 2537 Å ultraviolet rays. Note that exposure to such lights for an extended period will therefore affect system reliability. If the chip is used where it is exposed to any light with a wavelength of 4000 Å or less, cover the translucent part, for example, with a protective seal to prevent the chip from being exposed to the light.

Exposure to light with a wavelength of 4,000 to 5,000 Å or more will not erase data in the device. If the light applied to the chip has a very high illuminance, however, the device may cause malfunction in the circuit for reasons of general semiconductor characteristics. Although the circuit will recover normal operation when exposure is stopped, the device requires proper countermeasures for use in a place exposed continuously to such light even though the wavelength is 4,000 Å or more.

5. Recommended Screening Conditions

High temperature aging is recommended as the pre-assembly screening procedure.

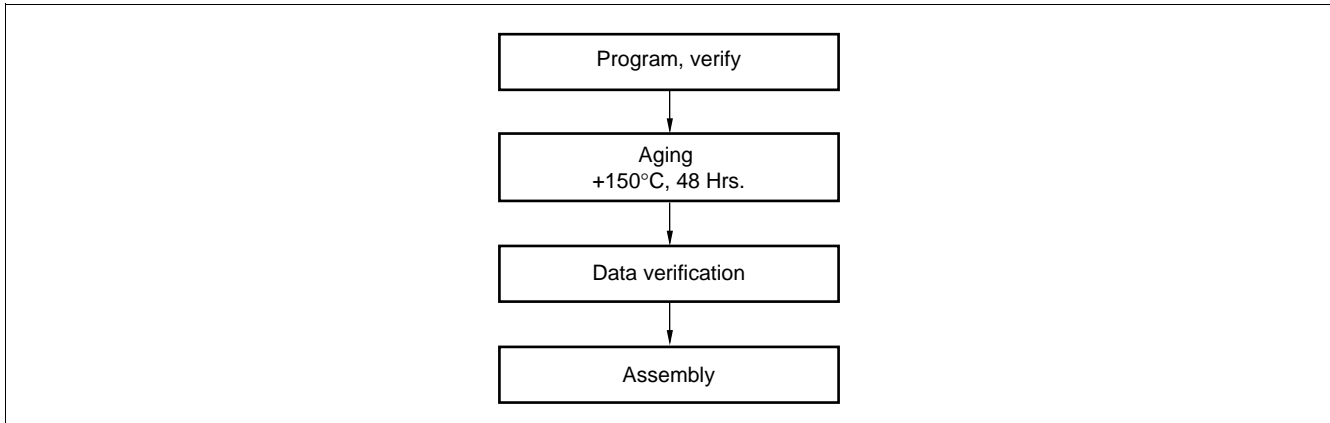

6. Programming Yield

MB90P214A/P214B cannot be write-tested for all bits due to their nature. Therefore the write yield cannot always be guaranteed to be 100%.

7. Pin Assignment in EPROM Mode

(1) Pins compatible with MBM27C1000

MBM27C1000		MB90P214A, MB90P214B, MB90W214A, MB90W214B		MBM27C1000		MB90P214A, MB90P214B, MB90W214A, MB90W214B	
Pin no.	Pin name	Pin no.	Pin name	Pin no.	Pin name	Pin no.	Pin name
1	V _{PP}	43	MD2 (V _{PP})	32	V _{CC}		
2	OE	59	P55	31	PGM	60	P56
3	A15	19	P37	30	N.C.		
4	A12	16	P34	29	A14	18	P36
5	A07	10	P27	28	A13	17	P35
6	A06	9	P26	27	A08	12	P30
7	A05	8	P25	26	A09	13	P31
8	A04	7	P24	25	A11	15	P33
9	A03	6	P23	24	A16	20	P40
10	A02	5	P22	23	A10	14	P32
11	A01	4	P21	22	CE	58	P54
12	A00	3	P20	21	D07	74	P07
13	D00	67	P00	20	D06	73	P06
14	D01	68	P01	19	D05	72	P05
15	D02	69	P02	18	D04	71	P04
16	GND			17	D03	70	P03

MB90210 Series

(2) Power supply and ground connection pins

Type	Pin no.	Pin name
Power supply	41	MD0
	42	MD1
	44	$\overline{\text{HST}}$
	66	V _{cc}
GND	11	V _{ss}
	30	AVRL
	31	AV _{ss}
	34	V _{ss}
	56	P52
	57	P53
	62	$\overline{\text{RST}}$
	63	V _{ss}

(3) Pins other than MBM27C1000-compatible pins

Pin no.	Pin name	Treatment
64	X0	Pull up to 4.7 k Ω .
65	X1	Open
1 2 21 to 27 28 29 32 33 35 to 40 45 to 50 51 to 53 54 55 61 75 to 80	P16 P17 P41 to P47 AV _{cc} AVRH P60 P61 P62 to P67 P70 to P75 P80 to P82 P50 P51 P57 P10 to P15	 <p>Connect a pull-up resistor of approximately 1 MΩ to each pin.</p>

■ BLOCK DIAGRAM

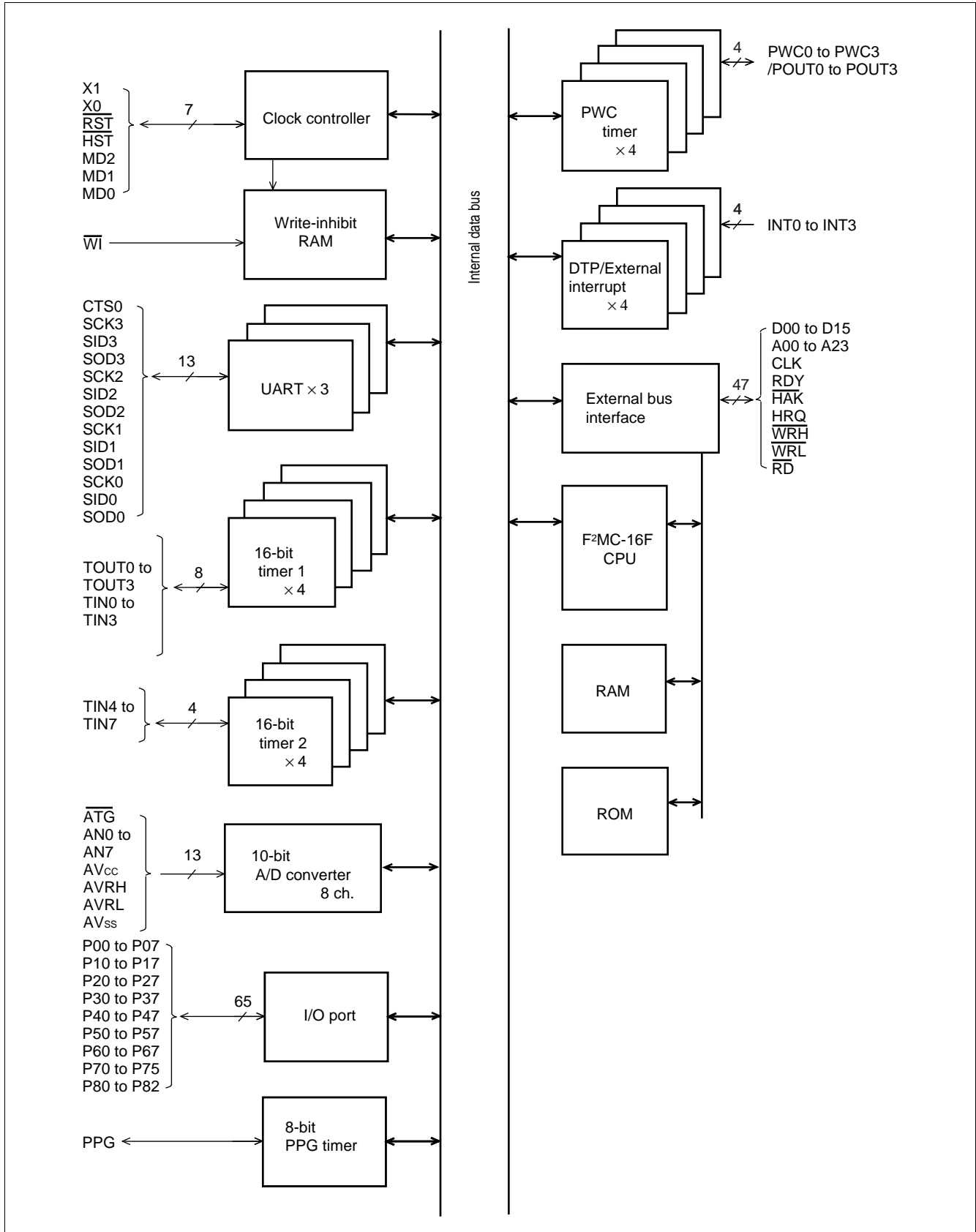

MEMORY MAP

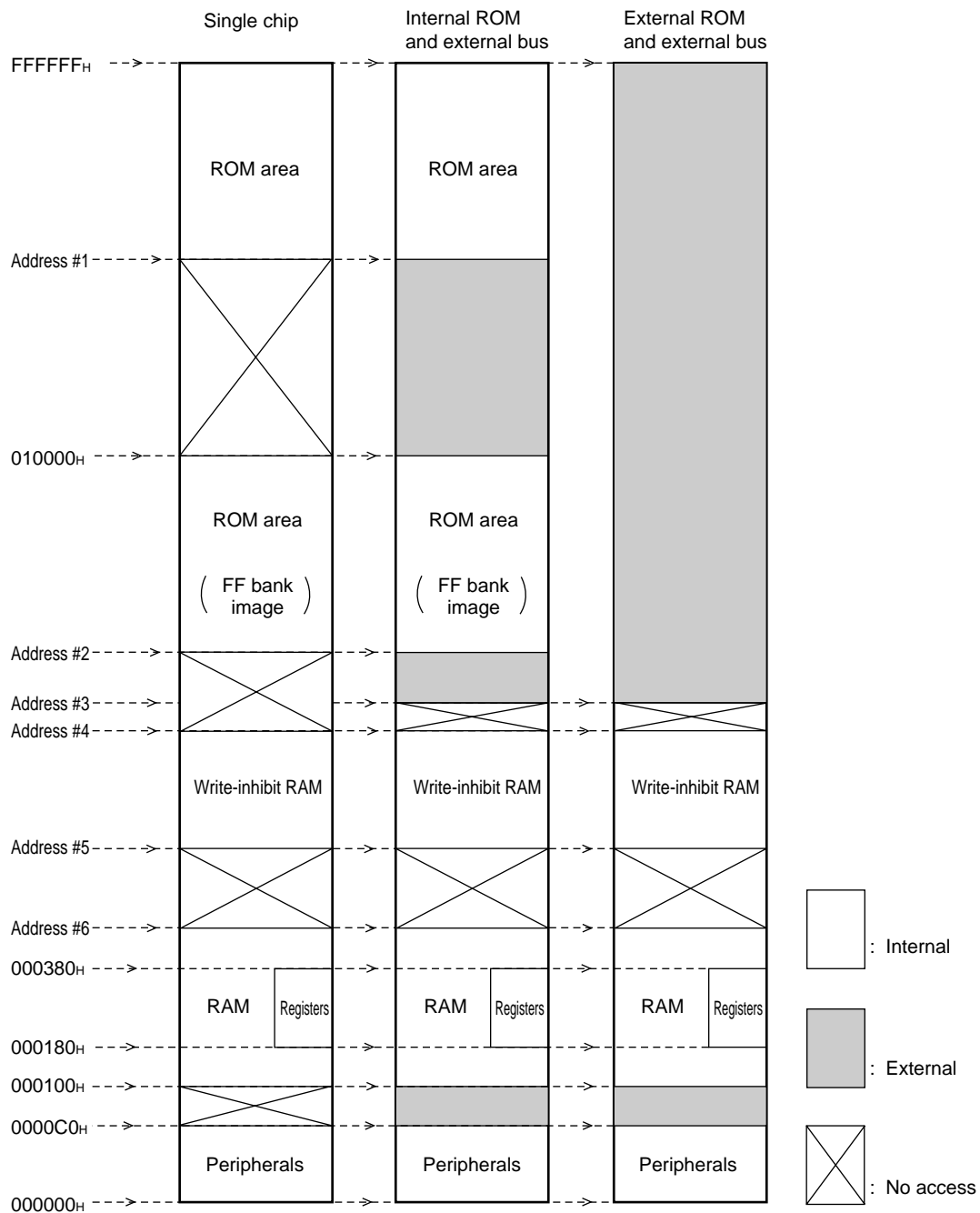

Type	Address #1	Address #2	Address #3	Address #4	Address #5	Address #6
MB90214	FF0000H	004000H	001300H	001200H	001100H	000D00H
MB90P214A/P214B MB90W214A/W214B	FF0000H	004000H	001300H	001200H	001100H	001100H
MB90V210	(FE0000H)	004000H	001300H	001300H	001100H	001100H

MB90210 Series

■ I/O MAP

Address	Register	Register name	Access	Resource name	Initial value
000000 _H *3	Port 0 data register	PDR0	R/W	Port 0	XXXXXXXX
000001 _H *3	Port 1 data register	PDR1	R/W	Port 1	XXXXXXXX
000002 _H *3	Port 2 data register	PDR2	R/W	Port 2	XXXXXXXX
000003 _H *3	Port 3 data register	PDR3	R/W	Port 3	XXXXXXXX
000004 _H *3	Port 4 data register	PDR4	R/W	Port 4	XXXXXXXX
000005 _H *3	Port 5 data register	PDR5	R/W	Port 5	XXXXXXXX
000006 _H	Port 6 data register	PDR6	R/W	Port 6	11111111
000007 _H	Port 7 data register	PDR7	R/W	Port 7	--XXXXXX
000008 _H	Port 8 data register	PDR8	R/W	Port 8	-----XXX
000009 _H to 0F _H	(Reserved area) *1				
000010 _H *3	Port 0 data direction register	DDR0	R/W	Port 0	00000000
000011 _H *3	Port 1 data direction register	DDR1	R/W	Port 1	00000000
000012 _H *3	Port 2 data direction register	DDR2	R/W	Port 2	00000000
000013 _H *3	Port 3 data direction register	DDR3	R/W	Port 3	00000000
000014 _H *3	Port 4 data direction register	DDR4	R/W	Port 4	00000000
000015 _H *3	Port 5 data direction register	DDR5	R/W	Port 5	00000000
000016 _H	Analog input enable register	ADER	R/W	Port 6	11111111
000017 _H	Port 7 data direction register	DDR7	R/W	Port 7	--000000
000018 _H	Port 8 data direction register	DDR8	R/W	Port 8	-----000
000019 _H to 1F _H	(Reserved area) *1				
000020 _H	Mode control register 0	UMC0	R/W	UART (ch.0)	00000100
000021 _H	Status register 0	USR0	R/W		00010000
000022 _H	Input data register 0/output data register 0	UIDR0/ UODR0	R/W		XXXXXXXX
000023 _H	Rate and data register 0	URD0	R/W		00000000
000024 _H	Mode control register 1	UMC1	R/W	UART (ch.1)	00000100
000025 _H	Status register 1	USR1	R/W		00010000
000026 _H	Input data register 1/output data register 1	UIDR1/ UODR1	R/W		XXXXXXXX
000027 _H	Rate and data register 1	URD1	R/W		00000000

(Continued)

MB90210 Series

Address	Register	Register name	Access	Resource name	Initial value
000028H	Mode control register 2	UMC2	R/W	UART (ch.2)	00000100
000029H	Status register 2	USR2	R/W		00010000
00002AH	Input data register 2/output data register 2	UIDR2/ UODR2	R/W		XXXXXXXX
00002BH	Rate and data register 2	URD2	R/W		00000000
00002CH	UART redirect control register	URDR	R/W	UART (ch.0/2)	---00000
00002DH to 2FH	(Reserved area) *1				
000030H	Interrupt/DTP enable register	ENIR	R/W	DTP/external interrupt	----0000
000031H	Interrupt/DTP factor register	EIRR	R/W		----0000
000032H	Request level setting register	ELVR	R/W		00000000
000033H	(Reserved area) *1				
000034H	AD control status register	ADCS	R/W	10-bit A/D converter	00000000
000035H					00000000
000036H to 37H	AD data register	ADCD	R/W *4		XXXXXXXX 0-----XX
000038H to 39H	Timer control status register 0	TMCSR0	R/W		16-bit reload timer 1 (ch.0)
00003AH to 3BH	Timer control status register 1	TMCSR1	R/W	16-bit reload timer 1 (ch.1)	00000000 ----0000
00003CH to 3DH	Timer control status register 2	TMCSR2	R/W	16-bit reload timer 1 (ch.2)	00000000 ----0000
00003EH to 3FH	Timer control status register 3	TMCSR3	R/W	16-bit reload timer 1 (ch.3)	00000000 ----0000
000040H	Timer 0 timer register	TMR0	R	16-bit reload timer 1 (ch.0)	XXXXXXXX
000041H					XXXXXXXX
000042H	Timer 0 reload register	TMRLR0	W		XXXXXXXX
000043H					XXXXXXXX
000044H	Timer 1 timer register	TMR1	R	16-bit reload timer 1 (ch.1)	XXXXXXXX
000045H					XXXXXXXX
000046H	Timer 1 reload register	TMRLR1	W		XXXXXXXX
000047H					XXXXXXXX

(Continued)

MB90210 Series

Address	Register	Register name	Access	Resource name	Initial value
000048 _H	Timer 2 timer register	TMR2	R	16-bit reload timer 1 (ch.2)	XXXXXXXX
000049 _H					XXXXXXXX
00004A _H	Timer 2 reload register	TMRLR2	W		XXXXXXXX
00004B _H					XXXXXXXX
00004C _H	Timer 3 timer register	TMR3	R	16-bit reload timer 1 (ch.3)	XXXXXXXX
00004D _H					XXXXXXXX
00004E _H	Timer 3 reload register	TMRLR3	W		XXXXXXXX
00004F _H					XXXXXXXX
000050 _H	Timer 4 timer register	TMR4	R	16-bit reload timer 2 (ch.4)	XXXXXXXX
000051 _H					XXXXXXXX
000052 _H	Timer 4 reload register	TMRLR4	W		XXXXXXXX
000053 _H					XXXXXXXX
000054 _H	Timer 5 timer register	TMR5	R	16-bit reload timer 2 (ch.5)	XXXXXXXX
000055 _H					XXXXXXXX
000056 _H	Timer 5 reload register	TMRLR5	W		XXXXXXXX
000057 _H					XXXXXXXX
000058 _H	Timer 6 timer register	TMR6	R	16-bit reload timer 2 (ch.6)	XXXXXXXX
000059 _H					XXXXXXXX
00005A _H	Timer 6 reload register	TMRLR6	W		XXXXXXXX
00005B _H					XXXXXXXX
00005C _H	Timer 7 timer register	TMR7	R	16-bit reload timer 2 (ch.7)	XXXXXXXX
00005D _H					XXXXXXXX
00005E _H	Timer 7 reload register	TMRLR7	W		XXXXXXXX
00005F _H					XXXXXXXX
000060 _H	Timer control status register 4	TMCSR4	R/W	16-bit reload timer 2 (ch.4)	00000000
000061 _H	(Reserved area) *1				
000062 _H	Timer control status register 5	TMCSR5	R/W	16-bit reload timer 2 (ch.5)	00000000
000063 _H	(Reserved area) *1				
000064 _H	Timer control status register 6	TMCSR6	R/W	16-bit reload timer 2 (ch.6)	00000000
000065 _H	(Reserved area) *1				

(Continued)

MB90210 Series

Address	Register	Register name	Access	Resource name	Initial value
000066H	Timer control status register 7	TMCSR7	R/W	16-bit reload timer 2 (ch.7)	00000000
000067H	(Reserved area) *1				
000068H	PWC0 divide ratio register	DIVR0	R/W	PWC timer (ch.0)	-----00
000069H	(Reserved area) *1				
00006AH	PWC1 divide ratio register	DIVR1	R/W	PWC timer (ch.1)	-----00
00006BH	(Reserved area) *1				
00006CH	PWC2 divide ratio register	DIVR2	R/W	PWC timer (ch.2)	-----00
00006DH	(Reserved area) *1				
00006EH	PWC3 divide ratio register	DIVR3	R/W	PWC timer (ch.3)	-----00
00006FH	(Reserved area) *1				
000070H	PWC0 control status register	PWCSR0	R/W	PWC timer (ch.0)	00000000
000071H					00000000
000072H	PWC0 data buffer register	PWCR0	R/W		00000000
000073H				00000000	
000074H	PWC1 control status register	PWCSR1	R/W	PWC timer (ch.1)	00000000
000075H					00000000
000076H	PWC1 data buffer register	PWCR1	R/W		00000000
000077H				00000000	
000078H	PWC2 control status register	PWCSR2	R/W	PWC timer (ch.2)	00000000
000079H					00000000
00007AH	PWC2 data buffer register	PWCR2	R/W		00000000
00007BH				00000000	
00007CH	PWC3 control status register	PWCSR3	R/W	PWC timer (ch.3)	00000000
00007DH					00000000
00007EH	PWC3 data buffer register	PWCR3	R/W		00000000
00007FH				00000000	
000080H to 87H	(Reserved area) *1				
000088H	PPG operation mode control register	PPGC	R/W	8-bit PPG timer	0000--1
000089H	(Reserved area) *1				

(Continued)

MB90210 Series

Address	Register	Register name	Access	Resource name	Initial value
00008A _H	PPG reload register	PRL	R/W	8-bit PPG timer	XXXXXXXX
00008B _H					XXXXXXXX
00008C _H to 8D _H	(Reserved area) *1				
00008E _H	WI control register	WICR	R/W	Write-inhibit RAM	---X----
00008F _H to 9E _H	(Reserved area) *1				
00009F _H	Delayed interrupt source generate/ release register	DIRR	R/W	Delayed interrupt generation module	-----0
0000A0 _H	Standby control register	STBYC	R/W	Low-power consumption mode	0001****
0000A1 _H to A2 _H	(Reserved area) *1				
0000A3 _H	Middle address control register	MACR	W	External pin	#####
0000A4 _H	Upper address control register	HACR	W		#####
0000A5 _H	External pin control register	EPCR	W		##0-0#00
0000A6 _H to A7 _H	(Reserved area) *1				
0000A8 _H	Watchdog timer control register	WTC	R/W	Watchdog timer	XXXXXXXX
0000A9 _H	Timebase timer control register	TBTC	R/W	Timebase timer	1--00000
0000AA _H to AF _H	(Reserved area) *1				
0000B0 _H	Interrupt control register 00	ICR00	R/W	Interrupt controller	00000111
0000B1 _H	Interrupt control register 01	ICR01	R/W		00000111
0000B2 _H	Interrupt control register 02	ICR02	R/W		00000111
0000B3 _H	Interrupt control register 03	ICR03	R/W		00000111
0000B4 _H	Interrupt control register 04	ICR04	R/W		00000111
0000B5 _H	Interrupt control register 05	ICR05	R/W		00000111
0000B6 _H	Interrupt control register 06	ICR06	R/W		00000111
0000B7 _H	Interrupt control register 07	ICR07	R/W		00000111
0000B8 _H	Interrupt control register 08	ICR08	R/W		00000111
0000B9 _H	Interrupt control register 09	ICR09	R/W		00000111

(Continued)

(Continued)

Address	Register	Register name	Access	Resource name	Initial value
0000BA _H	Interrupt control register 10	ICR10	R/W	Interrupt controller	00000111
0000BB _H	Interrupt control register 11	ICR11	R/W		00000111
0000BC _H	Interrupt control register 12	ICR12	R/W		00000111
0000BD _H	Interrupt control register 13	ICR13	R/W		00000111
0000BE _H	Interrupt control register 14	ICR14	R/W		00000111
0000BF _H	Interrupt control register 15	ICR15	R/W		00000111
0000C0 _H to FF _H	(External area) *2				

Initial value

0: The initial value of this bit is 0.

1: The initial value of this bit is 1.

X: The initial value of this bit is undefined.

–: This bit is not used. The initial value is undefined.

*: The initial value of this bit varies with the reset source.

#: The initial value of this bit varies with the operation mode.

*1: Access inhibited

*2: The only area available for the external access below address 0000FF_H is this area. Accesses to these addresses are handled as accesses to an external I/O area.

*3: When the external bus is enabled, do not access any register not serving as a general-purpose port in the areas from address 000000_H to 000005_H and from 000010_H to 000015_H.

*4: Writing to bit 15 is possible. Writing to other bits is used as a test function.

MB90210 Series

■ INTERRUPT SOURCES AND INTERRUPT VECTORS/INTERRUPT CONTROL REGISTERS

Interrupt source	EI ² OS support	Interrupt vector		Interrupt control register	
		No.	Address	ICR	Address
Reset	×	# 08	08 _H	FFFFDC _H	—
INT9 instruction	×	# 09	09 _H	FFFFD8 _H	—
Exceptional	×	# 10	0A _H	FFFFD4 _H	—
UART interrupt #0	△	# 11	0B _H	FFFFD0 _H	ICR00
UART interrupt #1	△	# 12	0C _H	FFFFC _H	
UART interrupt #2	△	# 13	0D _H	FFFFC8 _H	ICR01
UART interrupt #3	△	# 14	0E _H	FFFFC4 _H	
PWC timer # 0 · count completed	△	# 15	0F _H	FFFFC0 _H	ICR02
PWC timer # 0 · overflow	△	# 16	10 _H	FFFFBC _H	
PWC timer # 1 · count completed	△	# 17	11 _H	FFFFB8 _H	ICR03
PWC timer # 1 · overflow	△	# 18	12 _H	FFFFB4 _H	
PWC timer # 2 · count completed	△	# 19	13 _H	FFFFB0 _H	ICR04
PWC timer # 2 · overflow	△	# 20	14 _H	FFFFAC _H	
PWC timer # 3 · count completed	△	# 21	15 _H	FFFFA8 _H	ICR05
PWC timer # 3 · overflow	△	# 22	16 _H	FFFFA4 _H	
16-bit reload timer 1 # 0 overflow	△	# 23	17 _H	FFFFA0 _H	ICR06
16-bit reload timer 1 # 1 overflow	△	# 24	18 _H	FFFF9C _H	
16-bit reload timer 1 # 2 overflow	△	# 25	19 _H	FFFF98 _H	ICR07
16-bit reload timer 1 # 3 overflow	△	# 26	1A _H	FFFF94 _H	
16-bit reload timer 2 # 4 overflow	△	# 27	1B _H	FFFF90 _H	ICR08
16-bit reload timer 2 # 5 overflow	△	# 28	1C _H	FFFF8C _H	
16-bit reload timer 2 # 6 overflow	△	# 29	1D _H	FFFF88 _H	ICR09
16-bit reload timer 2 # 7 overflow	△	# 30	1E _H	FFFF84 _H	
A/D converter count completed	△	# 31	1F _H	FFFF80 _H	ICR10
Timebase timer interval interrupt	△	# 32	20 _H	FFFF7C _H	
UART2 · transmission completed	△	# 33	21 _H	FFFF78 _H	ICR11
UART2 · reception completed	△	# 34	22 _H	FFFF74 _H	

(Continued)

(Continued)

Interrupt source	EI ² OS support	Interrupt vector			Interrupt control register	
		No.	Address	Address	ICR	Address
UART1 · transmission completed	○	# 35	23 _H	FFFF70 _H	ICR12	0000BC _H
UART1 · reception completed	○	# 36	24 _H	FFFF6C _H		
UART0 · transmission completed	◎	# 37	25 _H	FFFF68 _H	ICR13	0000BD _H
UART0 · reception completed	◎	# 39	27 _H	FFFF60 _H	ICR14	0000BE _H
Delayed interrupt generation module	×	# 42	2A _H	FFFF54 _H	ICR15	0000BF _H
Stack fault	×	# 255	FF _H	FFFC00 _H	—	—

◎: EI²OS is supported (with stop request).

○: EI²OS is supported; however, since two interrupt sources are allocated to a single ICR, in case EI²OS is used for one of the two, EI²OS and ordinary interrupt are not both available for the other (with stop request).

△: EI²OS is supported; however, since two interrupt sources are allocated to a single ICR, in case EI²OS is used for one of the two, EI²OS and ordinary interrupt are not both available for the other (with no stop request).

×: EI²OS is not supported.

MB90210 Series

PERIPHERAL RESOURCES

1. Parallel Ports

The MB90210 series has 57 I/O pins and 8 open-drain I/O pins.

Ports 0 to 5, 7, and 8 are I/O ports. Each of these ports serves as an input port when the data direction register value is 0 and as an output port when the value is 1.

Port 6 is an open-drain port, which may be used as a port when the analog input enable register value is 0.

(1) Register Configuration

• Port data registers 0 to 8 (PDR0 to PDR8)

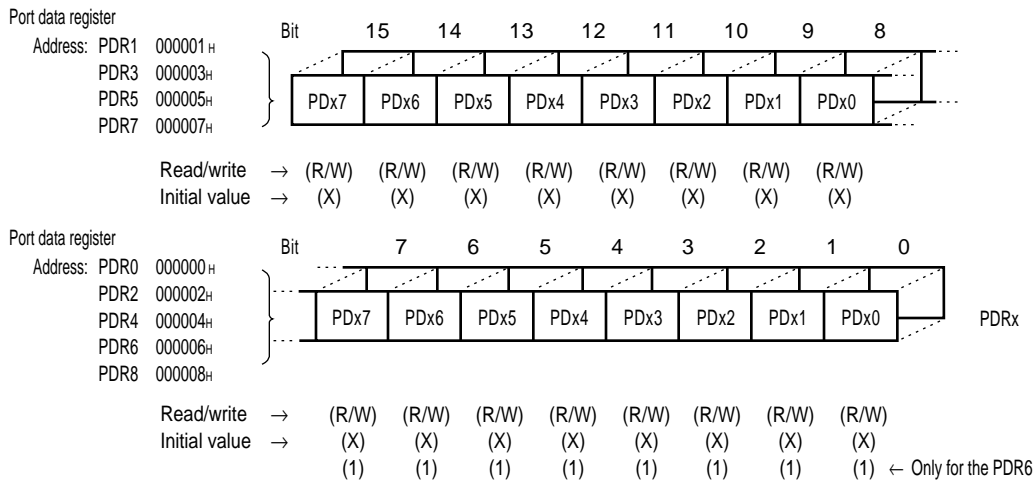

Note: No register bit is included in bits 7 and 6 of port 7 or bits 7 to 3 of port 8.

• Port direction registers 0 to 5, 7, and 8 (DDR0 to DDR5, DDR7, and DDR8)

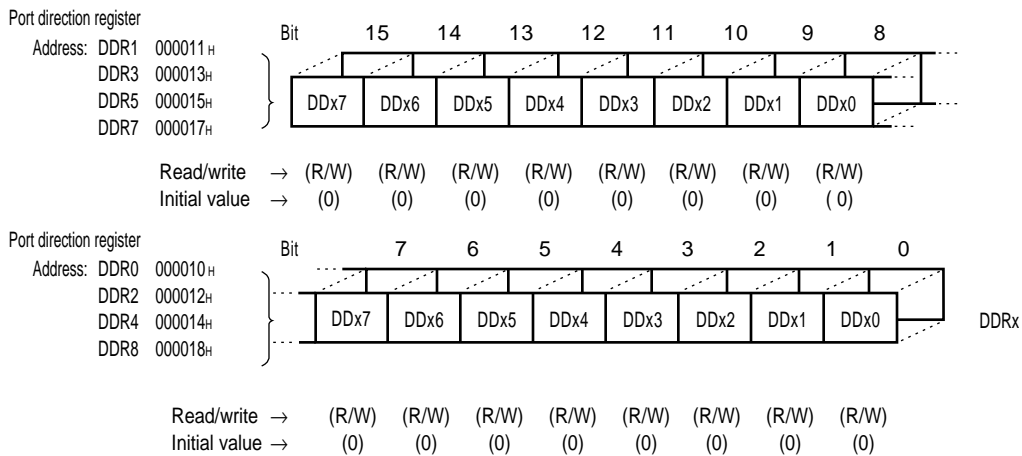

Note: No register bit is included in bits 7 and 6 of port 7 or bits 7 to 3 of port 8.
Port 6 has no DDR.

- Analog input enable register (ADER)

Analog input enable register		Bit	7	6	5	4	3	2	1	0	
Address: ADER 000016 _H			ADE7	ADE6	ADE5	ADE4	ADE3	ADE2	ADE1	ADE0	ADER
Read/write	→		(R/W)	(R/W)	(R/W)	(R/W)	(R/W)	(R/W)	(R/W)	(R/W)	
Initial value	→		(1)	(1)	(1)	(1)	(1)	(1)	(1)	(1)	

(2) Block Diagram

- I/O port (Port 0 to 5, 7, and 8)

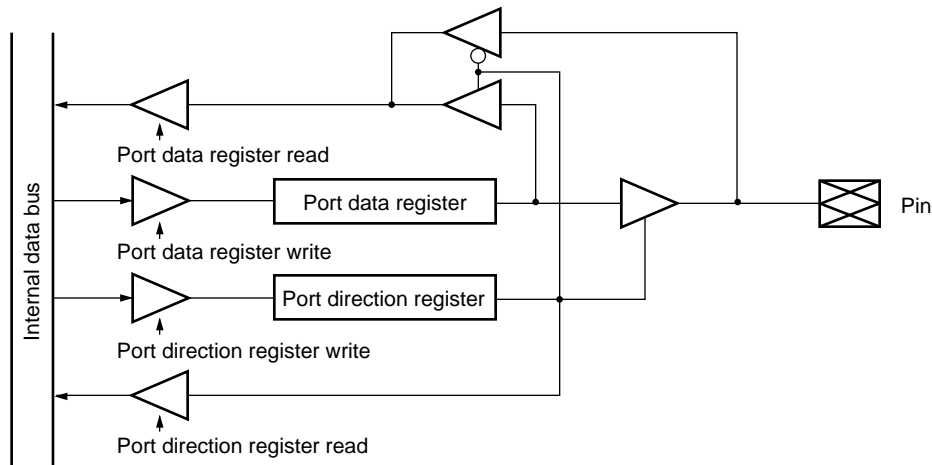

- I/O port with an open-drain output (Port 6)

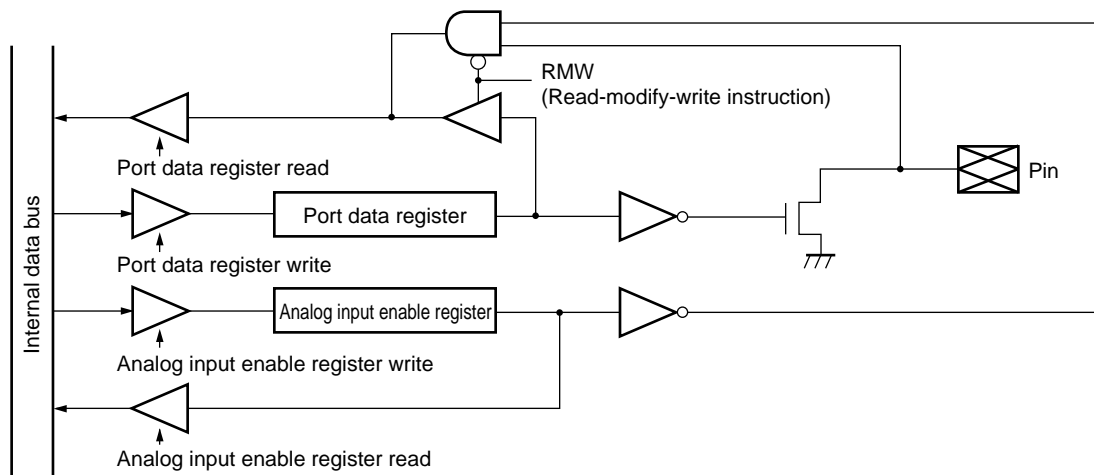

MB90210 Series

2. 16-bit Reload Timer 1 (with Event Count Function)

The 16-bit reload timer 1 consists of a 16-bit down counter, a 16-bit reload register, an input pin (TIN), an output pin (TOUT), and a control register. The input clock can be selected from among three internal clocks and one external clock. At the output pin (TOUT), the pulses in the toggled output waveform are output in the reload mode; the rectangular pulses indicating that the timer is counting are in the single-shot mode. The input pin (TIN) can be used for event input in the event count mode, and for trigger input or gate input in the internal clock mode.

MB90210 series contains four channels for this timer.

(1) Register Configuration

• Timer control status register (TMCSR)

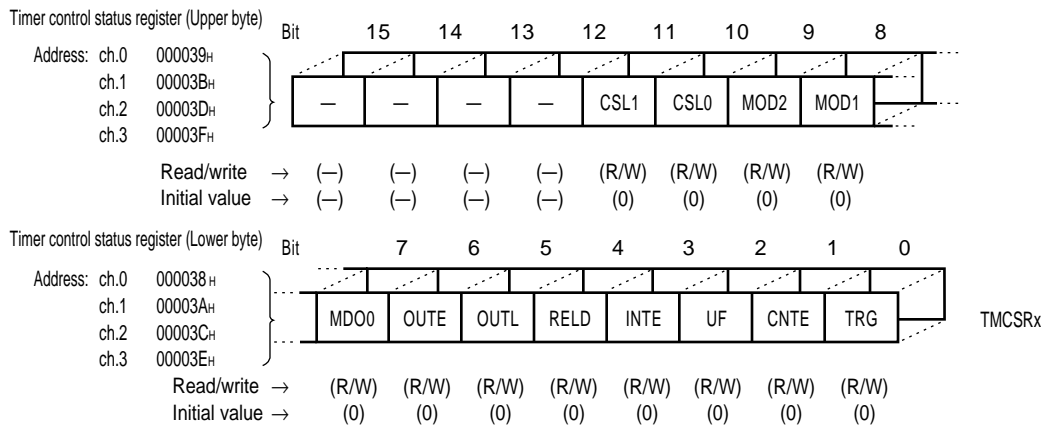

• Timer register (TMR)

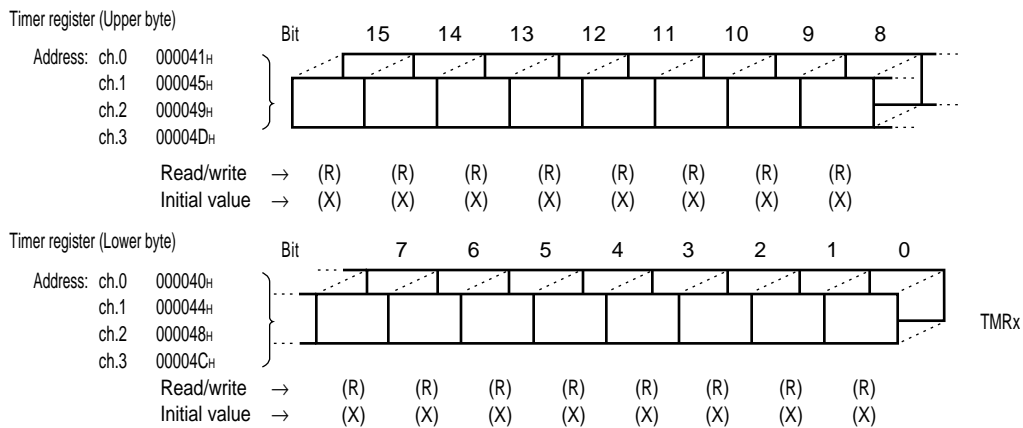

• Reload register (TMRLR)

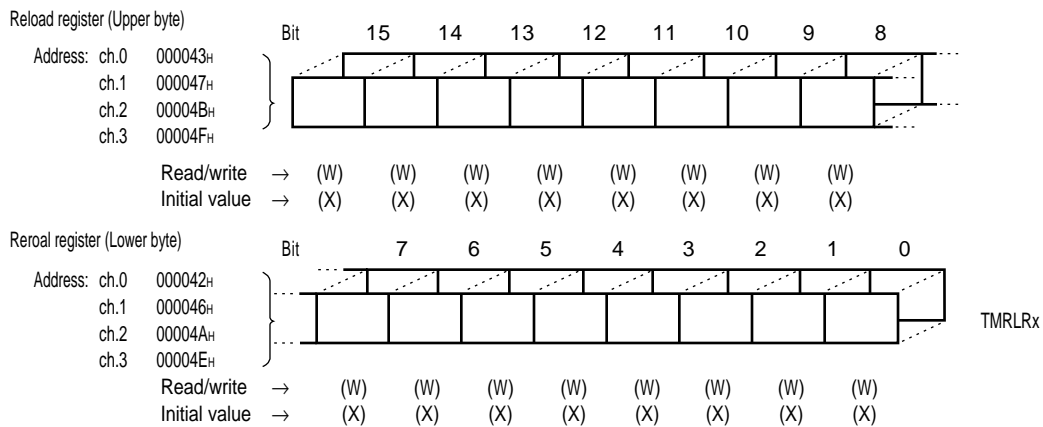

(2) Block Diagram

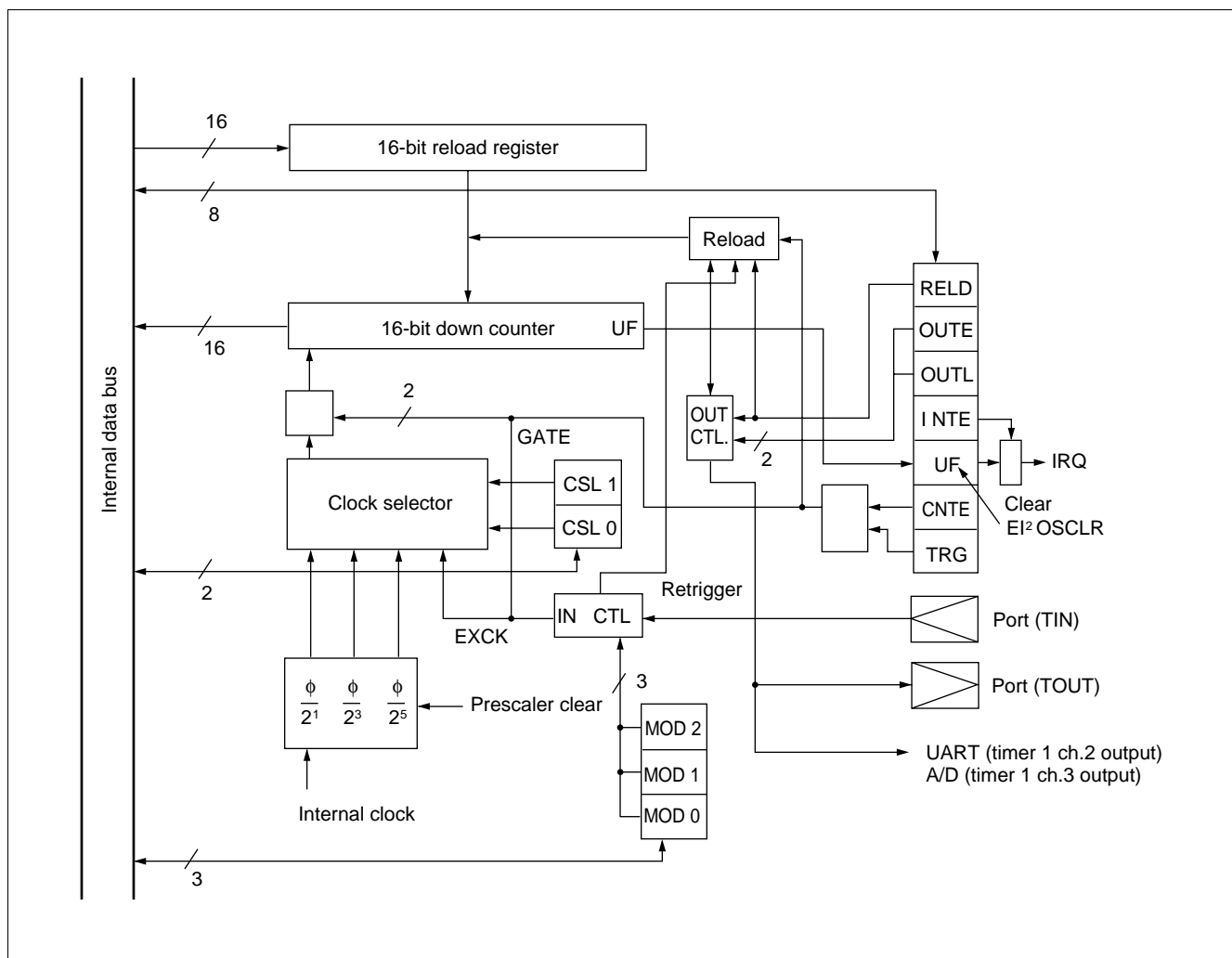

MB90210 Series

3. 16-bit Reload Timer 2 (with Gate Mode)

The 16-bit reload timer 2 consists of a 16-bit down counter, a 16-bit reload register, an input pin (TIN), and an 8-bit control register. The input clock can be selected from among four internal clocks.

The MB90210 series contains four channels for this timer.

(1) Register Configuration

- **Timer control status register (TMCSR)**

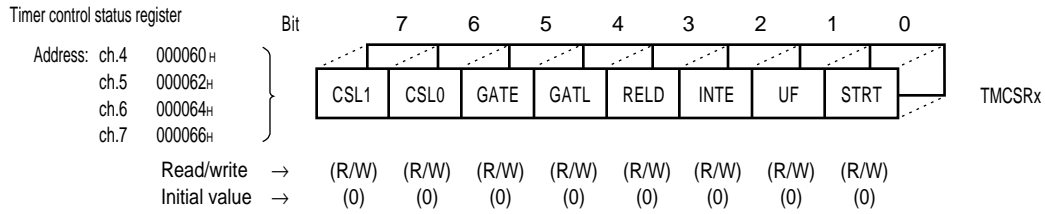

- **Timer register (TMR)**

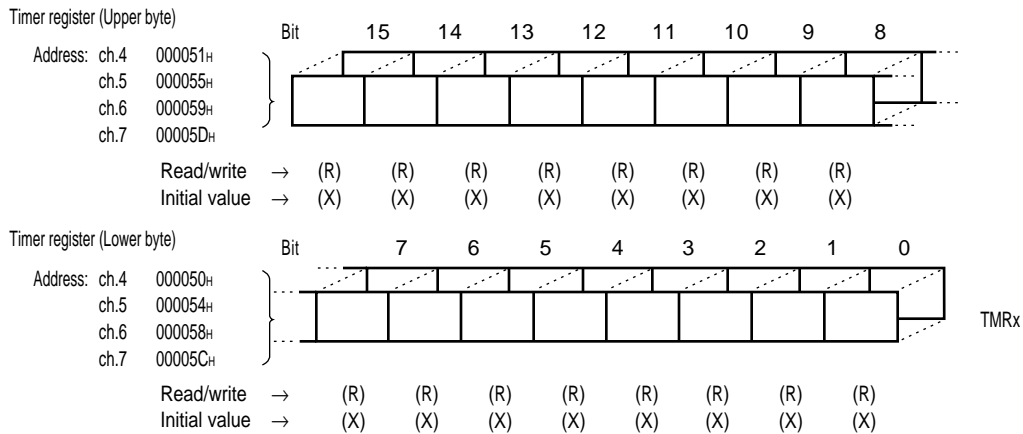

- **Reload register (TMRLR)**

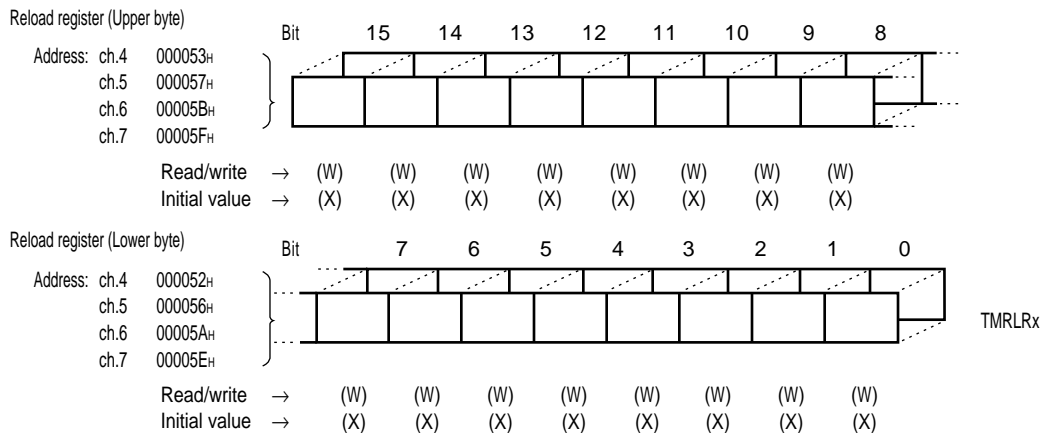

(2) Block Diagram

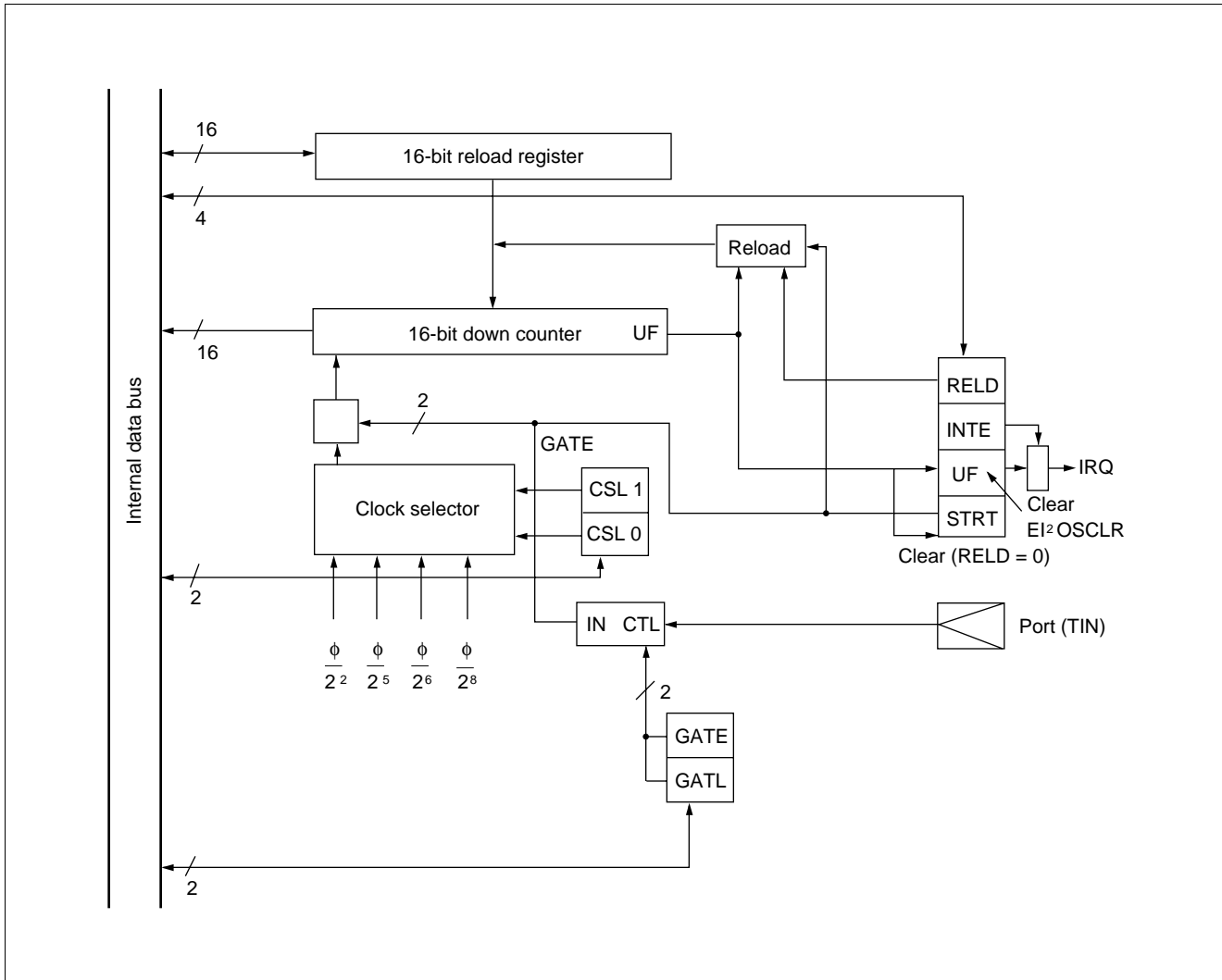

MB90210 Series

4. UART

The UART is a serial I/O port for synchronous or asynchronous communication with external resources. It has the following features:

- Full duplex double buffer
- Data transfer synchronous or asynchronous with clock pulses
- Multiprocessor mode support (Mode 2)
- Built-in dedicated baud-rate generator (Nine types)
- Arbitrary baud-rate setting from external clock input or internal timer (Use the 16-bit reload timer 1 channel 2 for internal timer.)
- Variable data length (7 to 9 bits (without parity bit); 6 to 8 bits (with parity bit))
- Variable data length (7 to 9 bit no parity, 6 to 8 bit with parity)
- Error detection function (Framing, overrun, parity)
- Interrupt function (Two sources for transmission and reception)
- Transfer in NRZ format

The MB90210 series contains three channels for the UART.
 UART channel 0 has the CTS function.
 UART channel 2 provides dual I/O pin switching.

(1) Register Configuration

• Serial mode control register (UMC)

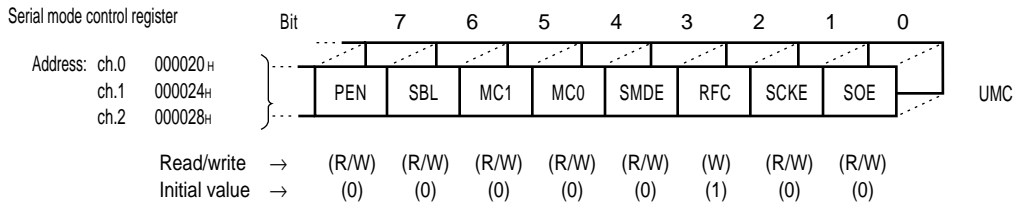

• Status register (USR)

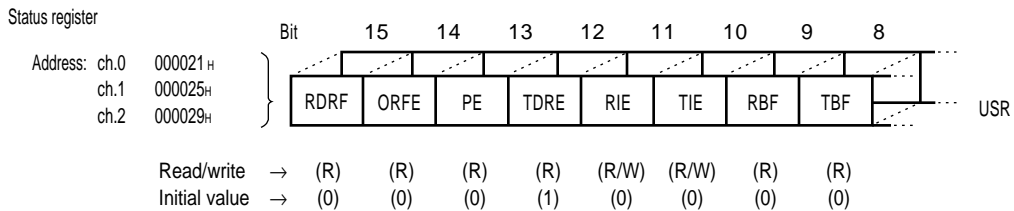

• Input data register (UIDR)/output data register (UODR)

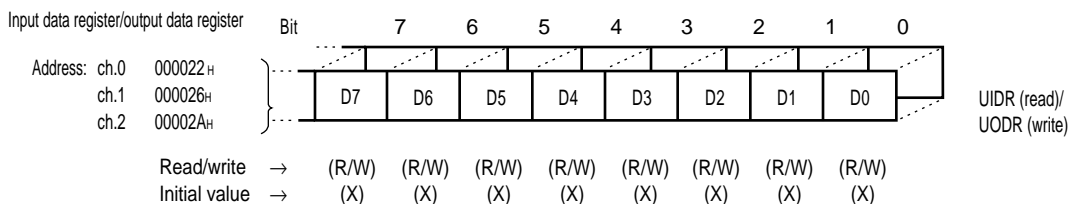

- **Rate and data register (URD)**

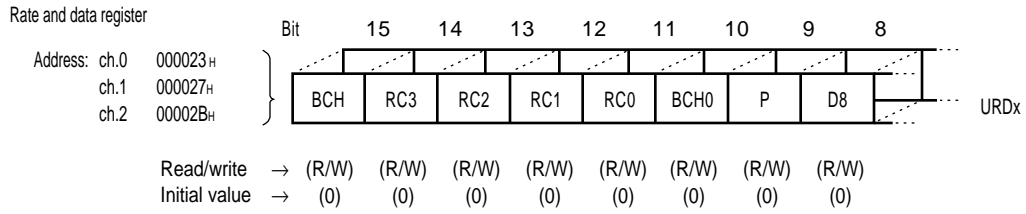

- **UART redirect control register (URDR)**

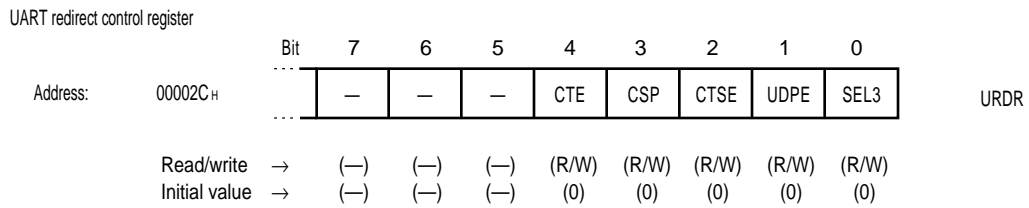

MB90210 Series

(2) Block Diagram

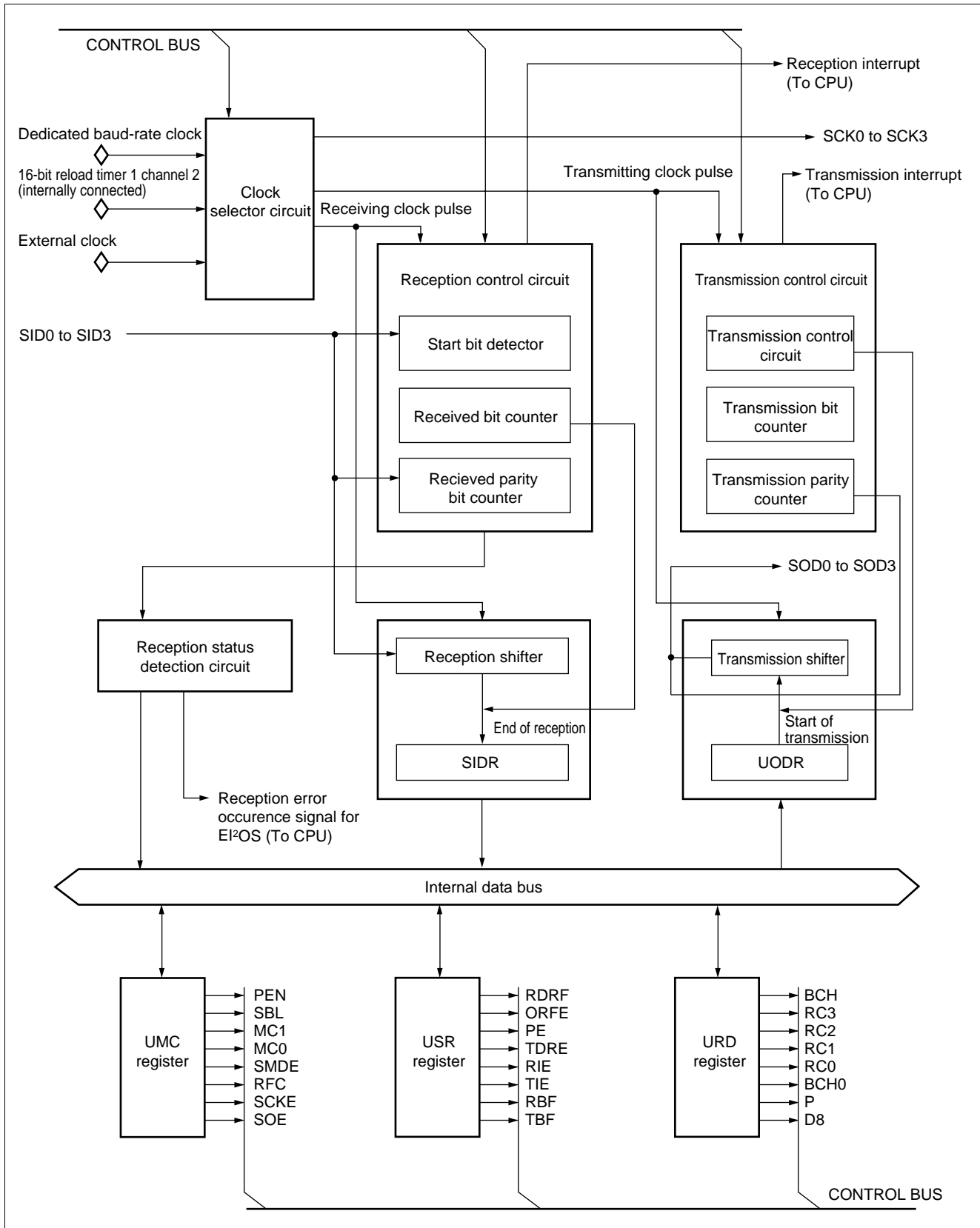

5. 10-bit A/D Converter

The 10-bit A/D converter converts the analog input voltage to a digital value. It has the following features:

- Conversion time: min.6.125 μ s per channel (at 16-MHz machine clock)
- RC-type successive approximation with built-in sample-and-hold circuit
- 10-bit or 8-bit resolution
- Eight analog input channels programmable for selection
 - Single conversion mode: Selects and converts one channel.
 - Scan conversion mode: Converts multiple consecutive channels (up to eight channels programmable).
 - Consecutive conversion mode: Converts a specified channel repeatedly.
 - Stop conversion mode: Converts one channel and suspends its own operation until the next activation (allowing synchronized conversion start).
- On completion of A/D conversion, the converter can generate an interrupt request to the CPU. This interrupt generation can activate the EI²OS to transfer the A/D conversion result to memory, making the converter suitable for continuous operation.
- Conversion can be activated by software, external trigger (falling edge), and/or timer (rising edge) as selected. Use the 16-bit reroad timer 1 channel 3 for the timer.

(1) Register Configuration

• A/D Control status register (ADCS1 and ADCS0)

A/D Control status register (Upper byte)		Bit	15	14	13	12	11	10	9	8	
Address:	000035 _H		BUSY	INT	INTE	PAUS	STS1	STS0	STRT	—	ADCS1
Read/write	→	(R/W)	(R/W)	(R/W)	(R/W)	(R/W)	(R/W)	(R/W)	(W)	(—)	
Initial value	→	(0)	(0)	(0)	(0)	(0)	(0)	(0)	(0)	(0)	

A/D Control status register (Lower byte)		Bit	7	6	5	4	3	2	1	0	
Address:	000034 _H		MD1	MD0	ANS2	ANS1	ANS0	ANE2	ANE1	ANE0	ADCS0
Read/write	→	(R/W)	(R/W)	(R/W)	(R/W)	(R/W)	(R/W)	(R/W)	(R/W)	(R/W)	
Initial value	→	(0)	(0)	(0)	(0)	(0)	(0)	(0)	(0)	(0)	

• A/D Data registers (ADCD1 and ADCD0)

A/D Data register (Upper byte)		Bit	15	14	13	12	11	10	9	8	
Address:	000037 _H		S10	—	—	—	—	—	D9	D8	ADCD1
Read/write	→	(W)	(—)	(—)	(—)	(—)	(—)	(—)	(R)	(R)	
Initial value	→	(0)	(—)	(—)	(—)	(—)	(—)	(—)	(X)	(X)	

A/D Data register (Lower byte)		Bit	7	6	5	4	3	2	1	0	
Address:	000036 _H		D7	D6	D5	D4	D3	D2	D1	D0	ADCD0
Read/write	→	(R)	(R)	(R)	(R)	(R)	(R)	(R)	(R)	(R)	
Initial value	→	(X)	(X)	(X)	(X)	(X)	(X)	(X)	(X)	(X)	

MB90210 Series

(2) Block Diagram

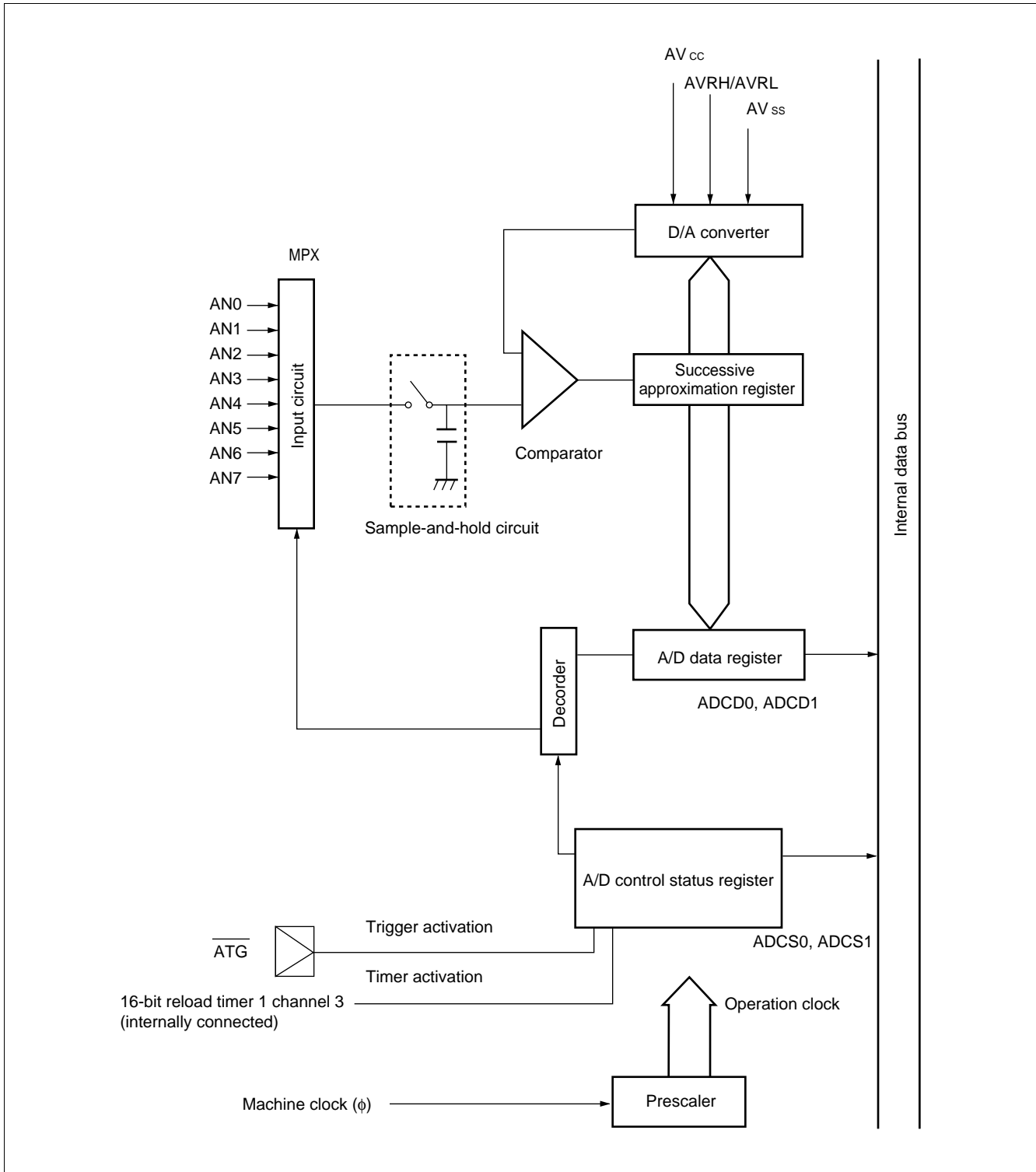

6. PWC(Pulse Width Count) Timer

The PWC (pulse width count) timer is a 16-bit multifunction up-count timer with an input-signal pulse-width count function and a reload timer function. The hardware configuration of this module is a 16-bit up-count timer, an input pulse divider with divide ratio control register, four count input pins, and a 16-bit control register. Using these components, the PWC timer provides the following features:

- Timer functions:
 - An interrupt request can be generated at set time intervals.
 - Pulse signals synchronized with the timer cycle can be output.
 - The reference internal clock can be selected from among three internal clocks.
- Pulse-width count functions:
 - The time between arbitrary pulse input events can be counted.
 - The reference internal clock can be selected from among three internal clocks.
 - Various count modes:
 - “H” pulse width (↑ to ↓) / “L” pulse width (↑ to ↓)
 - Rising-edge cycle (↑ to ↑) / Falling-edge cycle (↓ to ↓)
 - Count between edges (↑ or ↓ to ↓ or ↑)
 - Cycle count can be performed by 2²ⁿ division (n = 1, 2, 3, 4) of the input pulse, with an 8 bit input divider.
 - An interrupt request can be generated once counting has been performed.
 - The number of times counting is to be performed (once or subsequently) can be selected.

The MB90210 series contains four channels for the PWC timer.

(1) Register Configuration

• PWC control status register (PWCSR)

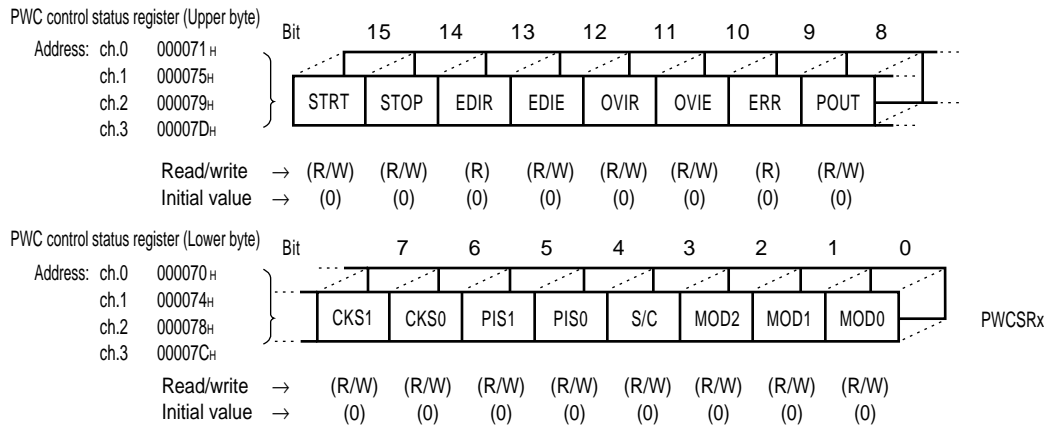

MB90210 Series

• PWC data buffer register (PWCR)

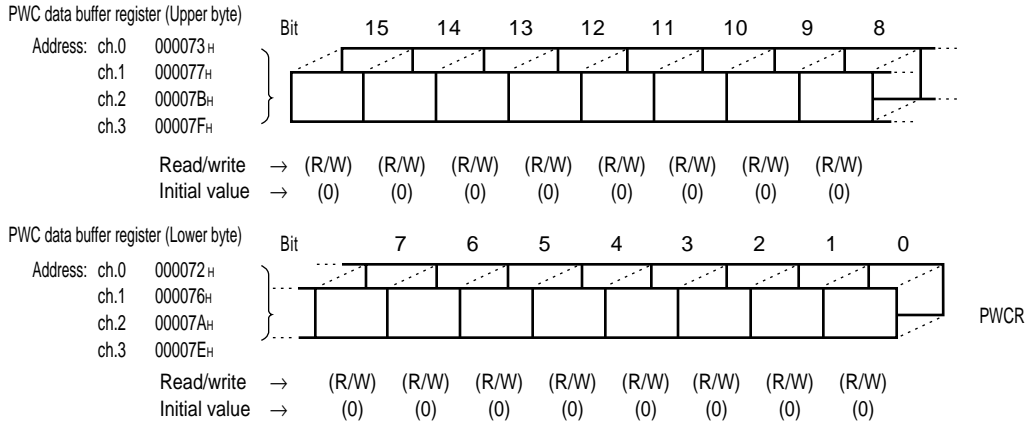

• PWC divide ratio control register (DIVR)

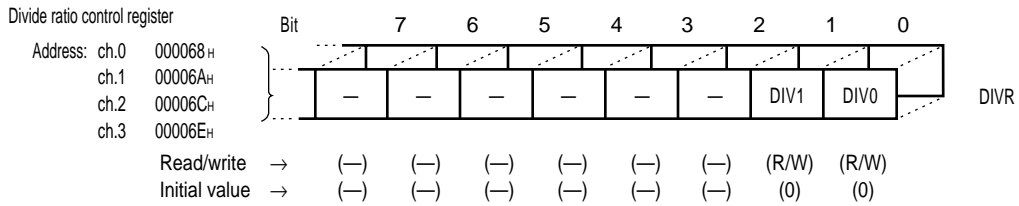

(2) Block Diagram

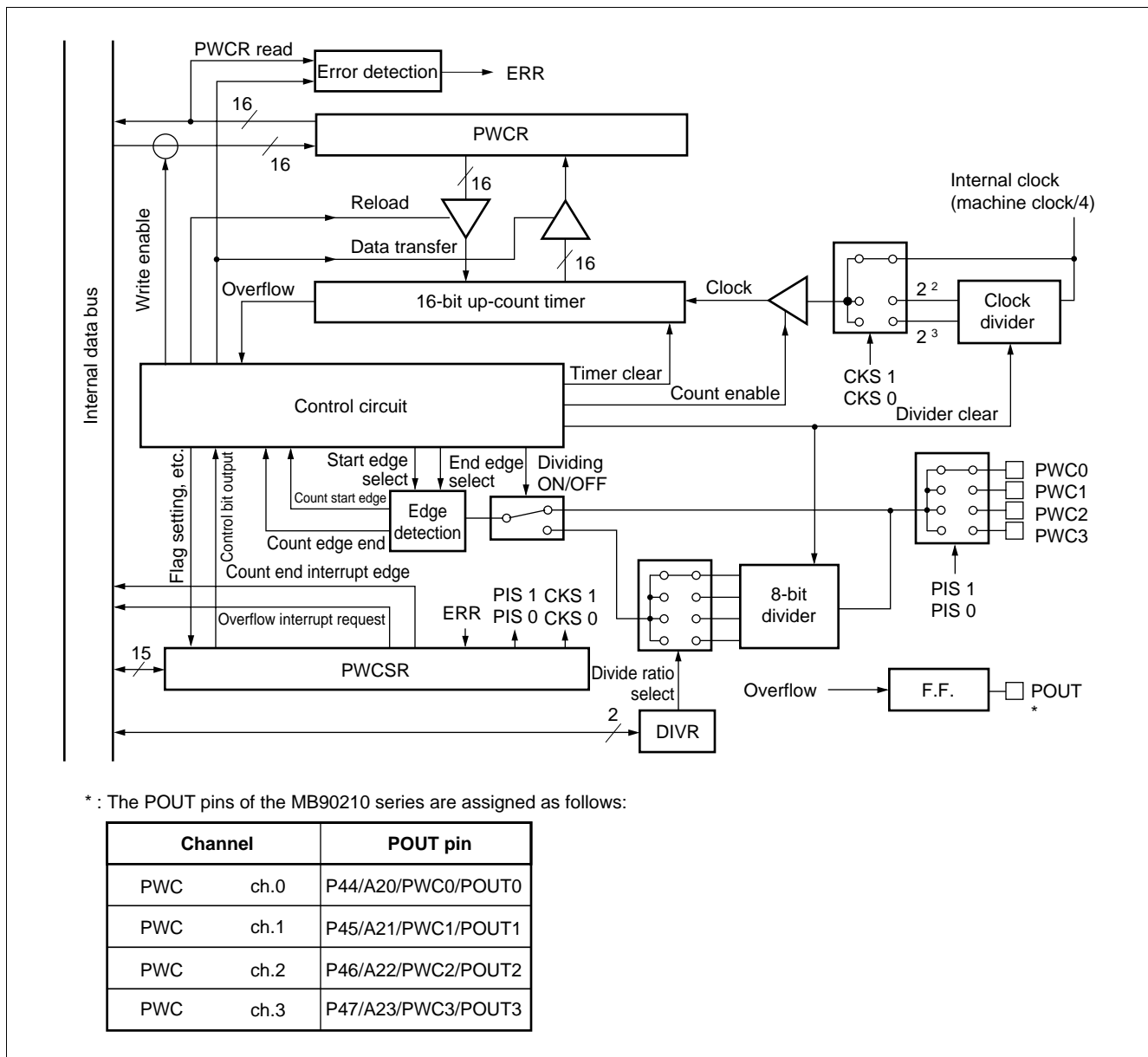

MB90210 Series

7. 8-bit PPG Timer

This block is an 8-bit reload timer module for PPG output by controlling pulse output according to the timer operation.

The hardware configuration of this block is an 8-bit down counter, two 8-bit reload registers, an 8-bit control register, and an external pulse output pin. Using these components, the module provides the following features:

PPG output operation: The module outputs pulse waves of any period and duty factor. It can also be used as a D/A converter using an external circuit.

(1) Register Configuration

- PPG operation mode control register (PPGC)

PPG operation mode control register		Bit	7	6	5	4	3	2	1	0	
Address:	000088 _H		PEN	PCKS	POE	Reserved	PUF	—	—	Reserved	PPGC
Read/write	→		(R/W)	(R/W)	(R/W)	(R/W)	(R/W)	(—)	(—)	(R/W)	
Initial value	→		(0)	(0)	(0)	(0)	(0)	(—)	(—)	(1)	

- PPG reload registers (PRLH and RRLH)

PPG reload register		Bit	15	14	13	12	11	10	9	8	
Address:	00008B _H										PRLH
Read/write	→		(R/W)	(R/W)	(R/W)	(R/W)	(R/W)	(R/W)	(R/W)	(R/W)	
Initial value	→		(X)	(X)	(X)	(X)	(X)	(X)	(X)	(X)	

PPG reload register		Bit	7	6	5	4	3	2	1	0	
Address:	00008A _H										PRLH
Read/write	→		(R/W)	(R/W)	(R/W)	(R/W)	(R/W)	(R/W)	(R/W)	(R/W)	
Initial value	→		(X)	(X)	(X)	(X)	(X)	(X)	(X)	(X)	

(2) Block Diagram

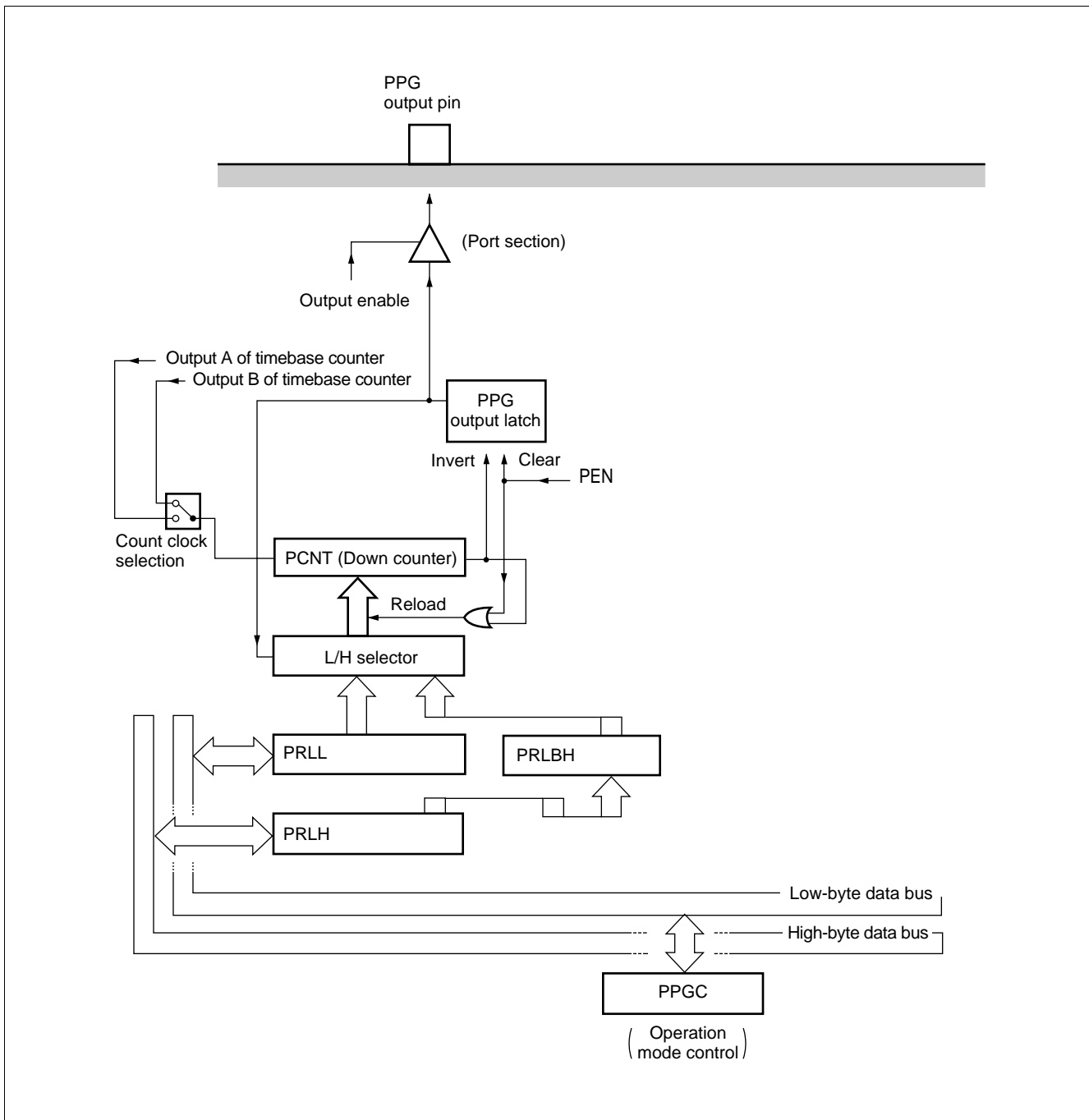

MB90210 Series

8. DTP/External Interrupt

The data transfer peripheral (DTP) is located between external peripherals and the F²MC-16F CPU. It receives a DMA request or an interrupt request generated by the external peripherals and reports it to the F²MC-16F CPU to activate the extended intelligent I/O service or interrupt handler. The user can select two request levels of “H” and “L” for extended intelligent I/O service or, and four request levels of “H,” “L,” rising edge and falling edge for external interrupt requests.

(1) Register Configuration

- **Interrupt/DTP enable register (ENIR)**

Interrupt/DTP enable register		Bit	7	6	5	4	3	2	1	0	
Address:	000030 _H		—	—	—	—	EN3	EN2	EN1	EN0	ENIR
Read/write	→		(—)	(—)	(—)	(—)	(R/W)	(R/W)	(R/W)	(R/W)	
Initial value	→		(—)	(—)	(—)	(—)	(0)	(0)	(0)	(0)	

- **Interrupt/DTP source register (EIRR)**

Interrupt/DTP source register		Bit	15	14	13	12	11	10	9	8	
Address:	000031 _H		—	—	—	—	ER3	ER2	ER1	ER0	EIRR
Read/write	→		(—)	(—)	(—)	(—)	(R/W)	(R/W)	(R/W)	(R/W)	
Initial value	→		(—)	(—)	(—)	(—)	(0)	(0)	(0)	(0)	

- **Request level setting register (ELVR)**

Request level setting register		Bit	7	6	5	4	3	2	1	0	
Address:	000032 _H		LB3	LA3	LB2	LA2	LB1	LA1	LB0	LA0	ELVR
Read/write	→		(R/W)	(R/W)	(R/W)	(R/W)	(R/W)	(R/W)	(R/W)	(R/W)	
Initial value	→		(0)	(0)	(0)	(0)	(0)	(0)	(0)	(0)	

(2) Block Diagram

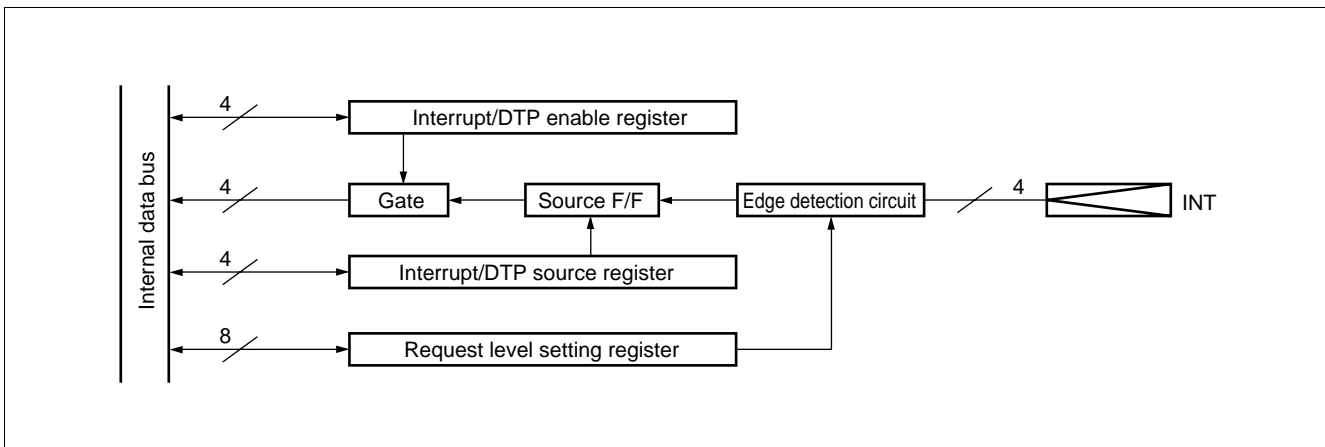

MB90210 Series

9. Watchdog Timer and Timebase Timer

The watchdog timer consists of a 2-bit watchdog counter using carry signals from an 18-bit timebase timer as the clock source, a control register, and a watchdog reset control section. The timebase timer consists of an 18-bit timer and an interval interrupt control circuit.

(1) Register Configuration

- Watchdog timer control register (WTC)

Watchdog timer control register		Bit	7	6	5	4	3	2	1	0	
Address:	0000A8 _H		PONR	STBR	WRST	ERST	SRST	WTE	WT1	WT0	WTC
Read/write	→		(R)	(R)	(R)	(R)	(R)	(W)	(W)	(W)	
Initial value	→		(X)	(X)	(X)	(X)	(X)	(X)	(X)	(X)	

- Timebase timer control register (TBTC)

Timebase timer control register		Bit	15	14	13	12	11	10	9	8	
Address:	0000A9 _H		Reserved	—	—	TBIE	TBOF	TBR	TBC1	TBC0	TBTC
Read/write	→		(W)	(—)	(—)	(R/W)	(R/W)	(R)	(R/W)	(R/W)	
Initial value	→		(1)	(—)	(—)	(0)	(0)	(0)	(0)	(0)	

(2) Block Diagram

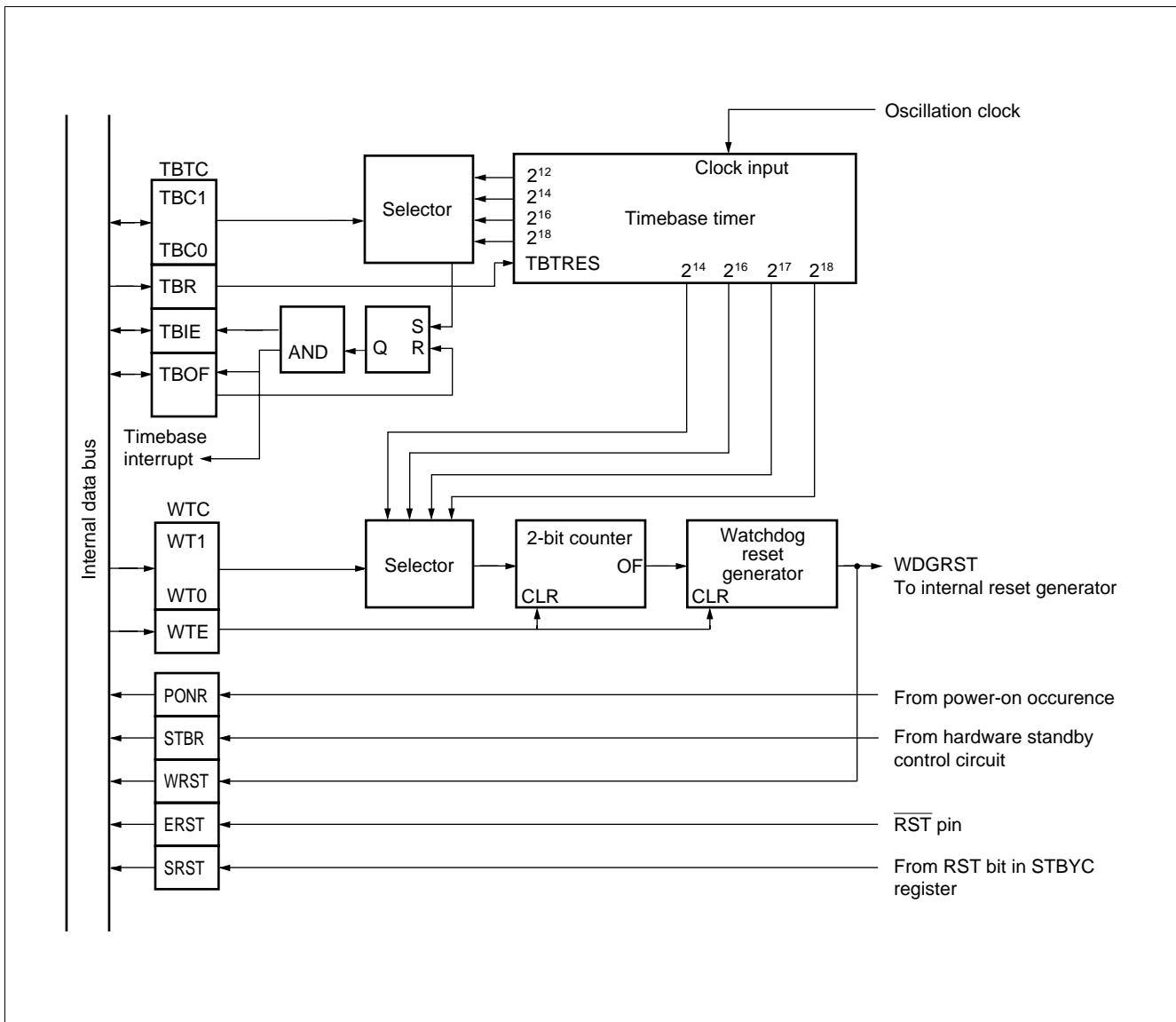

MB90210 Series

10. Delayed Interrupt Generation Module

The delayed interrupt generation module is used to generate an interrupt for task switching. Using this module allows an interrupt request to the F²MC-16F CPU to generate or cancel by software.

(1) Register Configuration

- Delayed interrupt source generate/release register (DIRR)

Delayed interrupt source generate/release register		Bit	15	14	13	12	11	10	9	8	
Address:	00009FH		—	—	—	—	—	—	—	R0	DIRR
Read/write	→	(—)	(—)	(—)	(—)	(—)	(—)	(—)	(—)	(R/W)	
Initial value	→	(—)	(—)	(—)	(—)	(—)	(—)	(—)	(—)	(0)	

(2) Block Diagram

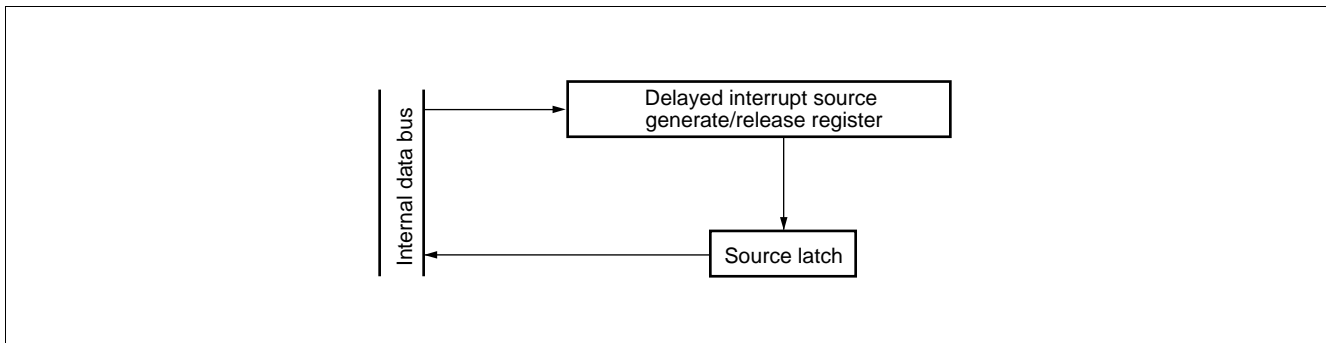

11. Write-inhibit RAM

The write-inhibit RAM is write-protectable with the \overline{WI} pin input. Maintaining the “L” level input to the \overline{WI} pin prevents a certain area of RAM from being written. The \overline{WI} pin has a 4-machine-cycle filter.

(1) Register Configuration

- **WI control register (WICR)**

WI control register	Bit	7	6	5	4	3	2	1	0	
Address: 00008EH		—	—	—	WI	—	—	—	—	WICR
Read/write	→	(—)	(—)	(—)	(R/W)	(—)	(—)	(—)	(—)	
Initial value	→	(—)	(—)	(—)	(1)	(—)	(—)	(—)	(—)	

(2) Write-inhibit RAM Area

Write-inhibit RAM area

001100_H to 0011FF_H (MB90214/P214A/P214B/W214A/W214B)

001100_H to 0012FF_H (MB90V210)

(3) Block Diagram

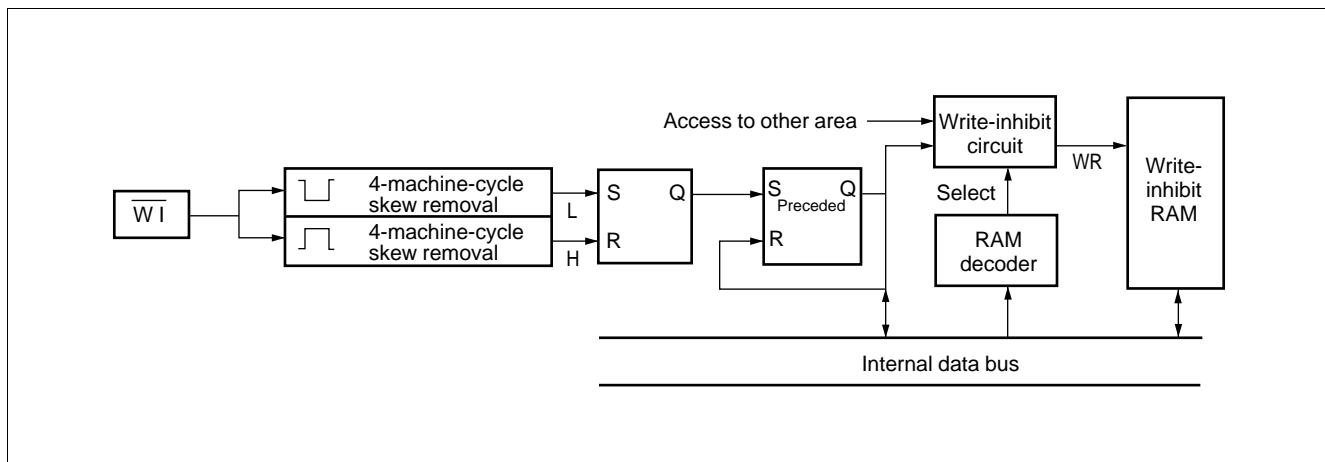

MB90210 Series

12. Low-power Consumption Modes, Oscillation Stabilization Delay Time, and Gear Function

The MB90210 series has three low-power consumption modes: the sleep mode, the stop mode, the hardware standby mode, and gear function.

Sleep mode is used to suspend only the CPU operation clock; the other components remain in operation. Stop mode and hardware standby mode stop oscillation, minimizing the power consumption while holding data.

The clock gear function divides the external clock frequency, which is used usually as it is, to provide a lower machine clock frequency. This function can therefore lower the overall operation speed without changing the oscillation frequency. The function can select the machine clock as a division of the frequency of crystal oscillation or external clock input by 1, 2, 4, or 16.

The OSC1 and OSC0 bits can be used to set the oscillation stabilization delay time for wake-up from stop mode or hardware standby mode.

(1) Register Configuration

- Standby control register (STBYC)

Standby control register	Bit	7	6	5	4	3	2	1	0	
Address: 0000A0H		STP	SLP	SPL	RST	OSC1	OSC0	CLK1	CLK0	STBYC
Read/write	→	(W)	(W)	(R/W)	(R/W)	(R/W)	(R/W)	(R/W)	(R/W)	
Initial value	→	(0)	(0)	(0)	(1)	(*)	(*)	(*)	(*)	

Note: The initial value(*) of bit0 to bit3 is changed by reset source.

(2) Block Diagram

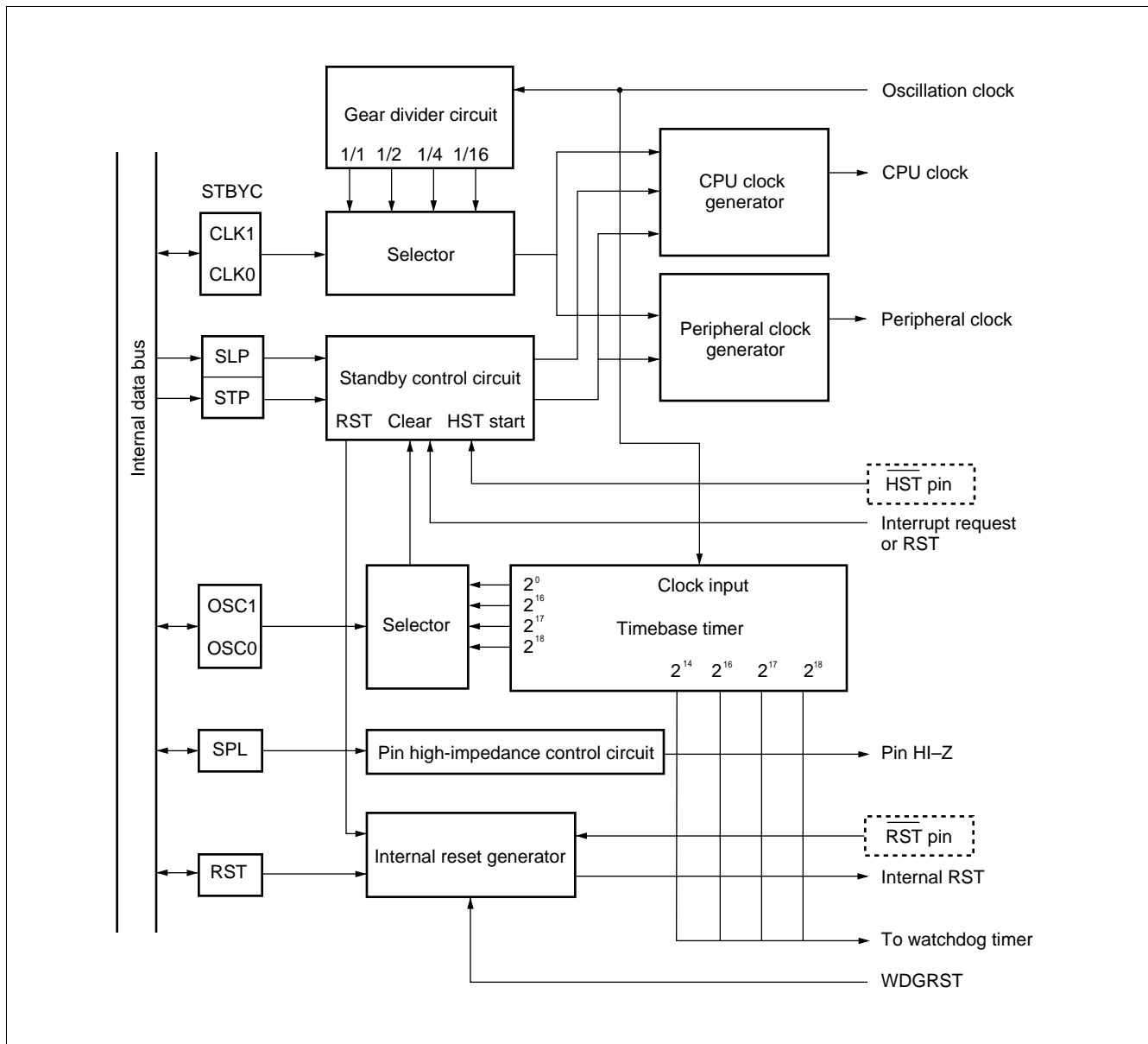

MB90210 Series

■ ELECTRICAL CHARACTERISTICS (MB90V210, device used for evaluation, is excluded)

1. Absolute Maximum Ratings

($V_{SS} = AV_{SS} = 0.0\text{ V}$)

Parameter	Symbol	Pin name	Value		Unit	Remarks
			Min.	Max.		
Power supply voltage	V_{CC}	V_{CC}	$V_{SS} - 0.3$	$V_{SS} + 7.0$	V	
Program voltage	V_{PP}	V_{PP}	$V_{SS} - 0.3$	13.0	V	MB90P214A/W214A MB90P214B/W214B
Analog power supply voltage	AV_{CC}	AV_{CC}	$V_{SS} - 0.3$	$V_{CC} + 0.3$	V	Power supply voltage for A/D converter
	AVRH AVRL	AVRH AVRL	$V_{SS} - 0.3$	AV_{CC}	V	Reference voltage for A/D converter
Input voltage	V_I^{*1}	—	$V_{SS} - 0.3$	$V_{CC} + 0.3$	V	
Output voltage	V_O	*2	$V_{SS} - 0.3$	$V_{CC} + 0.3$	V	
“L” level output current	I_{OL}	*3	—	20	mA	Rush current
“L” level total output current	ΣI_{OL}	*3	—	50	mA	Total output current
“H” level output current	I_{OH}	*2	—	-10	mA	Rush current
“H” level total output current	ΣI_{OH}	*2	—	-48	mA	Total output current
Power consumption	P_d	—	—	650	mW	
Operating temperature	T_A	—	-40	+105	°C	MB90214/P214B/W214B
			-40	+85	°C	MB90P214A/W214A
Storage temperature	T_{stg}	—	-55	+150	°C	

*1: V_I and V_O must not exceed $V_{CC} + 0.3\text{ V}$.

*2: Output pins

P00 to P07, P10 to P17, P20 to P27, P30 to P37, P40 to P47, P50 to P57, P70 to P75, P80 to P82

*3: Output pins

P00 to P07, P10 to P17, P20 to P27, P30 to P37, P40 to P47, P50 to P57, P60 to P67, P70 to P75, P80 to P82

WARNING: Semiconductor devices can be permanently damaged by application of stress (voltage, current, temperature, etc.) in excess of absolute maximum ratings. Do not exceed these ratings.

2. Recommended Operating Conditions

($V_{SS} = AV_{SS} = 0.0\text{ V}$)

Parameter	Symbol	Pin name	Value		Unit	Remarks
			Min.	Max.		
Power supply voltage	V_{CC}	V_{CC}	4.5	5.5	V	When operating
			3.0	5.5	V	Retains the RAM state in stop mode
Analog power supply voltage	AV_{CC}	AV_{CC}	4.5	$V_{CC} + 0.3$	V	Power supply voltage for A/D converter
	AV_{RH}	AV_{RH}	AV_{RL}	AV_{CC}	V	Reference voltage for A/D converter
	AV_{RL}	AV_{RL}	AV_{SS}	AV_{RH}	V	
Clock frequency	F_c	—	10	16	MHz	
Operating temperature	T_A^*	—	-40	+105	°C	Single-chip mode MB90214/P214B/W214B
			-40	+85	°C	Single-chip mode MB90P214A/W214A
			-40	+70	°C	External bus mode

* : Excluding the temperature rise due to the heat produced.

WARNING: Recommended operating conditions are normal operating ranges for the semiconductor device. All the device's electrical characteristics are warranted when operated within these ranges.

Always use semiconductor devices within the recommended operating conditions. Operation outside these ranges may adversely affect reliability and could result in device failure.

No warranty is made with respect to uses, operating conditions, or combinations not represented on the data sheet. Users considering application outside the listed conditions are advised to contact their FUJITSU representative beforehand.

MB90210 Series

3. DC Characteristics

Single-chip mode MB90214/P214B/W214B : ($V_{CC} = +4.5\text{ V to }+5.5\text{ V}$, $V_{SS} = 0.0\text{ V}$, $T_A = -40^\circ\text{C to }+105^\circ\text{C}$)
 MB90P214A/W214A : ($V_{CC} = +4.5\text{ V to }+5.5\text{ V}$, $V_{SS} = 0.0\text{ V}$, $T_A = -40^\circ\text{C to }+85^\circ\text{C}$)
 External bus mode : ($V_{CC} = +4.5\text{ V to }+5.5\text{ V}$, $V_{SS} = 0.0\text{ V}$, $T_A = -40^\circ\text{C to }+70^\circ\text{C}$)

Parameter	Symbol	Pin name	Condition	Value			Unit	Remarks
				Min.	Typ.	Max.		
“H” level input voltage	V_{IH}	*1	—	$0.7 V_{CC}$	—	$V_{CC} + 0.3$	V	CMOS level input
	V_{IHS}	*2	—	$0.8 V_{CC}$	—	$V_{CC} + 0.3$	V	Hysteresis input
	V_{IHM}	MD0 to MD2	—	$V_{CC} - 0.3$	—	$V_{CC} + 0.3$	V	
“L” level input voltage	V_{IL}	*1	—	$V_{SS} - 0.3$	—	$0.3 V_{CC}$	V	CMOS level input
	V_{ILS}	*2	—	$V_{SS} - 0.3$	—	$0.2 V_{CC}$	V	Hysteresis input
	V_{ILM}	MD0 to MD2	—	$V_{SS} - 0.3$	—	$V_{SS} + 0.3$	V	
“H” level output voltage	V_{OH}	*3	$V_{CC} = 4.5\text{ V}$ $I_{OH} = -4.0\text{ mA}$	$V_{CC} - 0.5$	—	V_{CC}	V	
	V_{OH1}	X1	$V_{CC} = 4.5\text{ V}$ $I_{OH} = -2.0\text{ mA}$	$V_{CC} - 2.3$	—	V_{CC}	V	
“L” level output voltage	V_{OL}	*4	$V_{CC} = 4.5\text{ V}$ $I_{OL} = 4.0\text{ mA}$	0	—	0.4	V	
	V_{OL1}	X1	$V_{CC} = 4.5\text{ V}$ $I_{OL} = 2.0\text{ mA}$	0	—	$V_{CC} - 2.3$	V	
Input leakage current	I_{I1}	*1 *2	$V_{CC} = 5.5\text{ V}$ $0.2 V_{CC} < V_I < 0.8 V_{CC}$	—	—	± 10	μA	Except pins with pull-up/pull-down resistor and $\overline{\text{RST}}$ pin
	I_{I2}	X0	$V_{CC} = 5.5\text{ V}$ $0.2 V_{CC} < V_{IH} < 0.8 V_{CC}$	—	—	± 25	μA	
Analog power supply voltage	I_A	AV_{CC}	$F_C = 16\text{ MHz}$	—	3	7	mA	
	I_{AH}		—	—	—	5^{*5}	μA	In stop mode, $T_A = +25^\circ\text{C}$
Input capacitance	C_{IN}	*6	—	—	10	—	pF	
Pull-up resistor	R_{pULU}	$\overline{\text{RST}}$	—	22	50	110	k Ω	^{*7} MB90214 MB90P214A/ W214A/P214B/ W214B
		MD1	—	110	300	650	k Ω	^{*7} MB90214
		Generic pin	—	22	50	110	k Ω	^{*7} MB90214
Pull-down resistor	R_{pULD}	MD0, MD2	—	110	300	650	k Ω	^{*7} MB90214
		Generic pin	—	22	50	110	k Ω	^{*7} MB90214

(Continued)

MB90210 Series

(Continued)

Parameter	Symbol	Pin name	Condition	Value			Unit	Remarks
				Min.	Typ.	Max.		
Power supply voltage*9	I _{CC}	V _{CC}	F _C = 16 MHz	—	50*8	80	mA	MB90214
				—	70*8	100	mA	MB90P214A/ W214A MB90P214B/ W214B
	I _{CCS}	V _{CC}	F _C = 16 MHz	—	—	40	mA	In sleep mode
	I _{CCH}	V _{CC}	—	—	5	10	μA	T _A = +25°C In stop mode In hardware standby input time

*1: CMOS level input (P00 to P07, P10 to P17, X0)

*2: Hysteresis input pins ($\overline{\text{RST}}$, $\overline{\text{HST}}$, P20 to P27, P30 to P37, P40 to P47, P50 to P57, P60 to P67, P70 to P75, P80 to P82)

*3: Output pins (P00 to P07, P10 to P17, P20 to P27, P30 to P37, P40 to P47, P50 to P57, P70 to P75, P80 to P82)

*4: Output pins (P00 to P07, P10 to P17, P20 to P27, P30 to P37, P40 to P47, P50 to P57, P60 to P67, P70 to P75, P80 to P82)

*5: The current value applies to the CPU stop mode with A/D converter inactive ($V_{CC} = AV_{CC} = AVRH = +5.5 \text{ V}$).

*6: Other than V_{CC} , V_{SS} , AV_{CC} and AV_{SS}

*7: A list of availabilities of pull-up/pull-down resistors

Pin name	MB90214	MB90P214A/W214A	MB90P214B/W214B
$\overline{\text{RST}}$	Availability of pull-up resistors is optionally defined.	Pull-up resistors available	Pull-up resistors available
MD1	Pull-up resistors available	Unavailable	Unavailable
MD0, MD2	Pull-down resistors available	Unavailable	Unavailable
Generic pin	Availability of pull-up/pull-down resistors is optionally defined.	Unavailable	Unavailable

*8: $V_{CC} = +5.0 \text{ V}$, $V_{SS} = 0.0 \text{ V}$, $T_A = +25^\circ\text{C}$, $F_C = 16 \text{ MHz}$

*9: Measurement condition of power supply current; external clock pin and output pin are open.

Measurement condition of V_{CC} ; see the table above mentioned.

MB90210 Series

2. AC Characteristics

(1) Clock Timing Standards

Single-chip mode MB90214/P214B/W214B : ($V_{CC} = +4.5\text{ V to }+5.5\text{ V}$, $V_{SS} = 0.0\text{ V}$, $T_A = -40^\circ\text{C to }+105^\circ\text{C}$)
 MB90P214A/W214A : ($V_{CC} = +4.5\text{ V to }+5.5\text{ V}$, $V_{SS} = 0.0\text{ V}$, $T_A = -40^\circ\text{C to }+85^\circ\text{C}$)
 External bus mode : ($V_{CC} = +4.5\text{ V to }+5.5\text{ V}$, $V_{SS} = 0.0\text{ V}$, $T_A = -40^\circ\text{C to }+70^\circ\text{C}$)

Parameter	Symbol	Pin name	Condition	Value			Unit	Remarks
				Min.	Typ.	Max.		
Clock frequency	F_c	X0, X1	—	10	—	16	MHz	
Clock cycle time	t_c	X0, X1	—	62.5	—	100	ns	$1/F_c$
Input clock pulse width	P_{WH} P_{WL}	X0	—	$0.4 t_c$	—	$0.6 t_c$	ns	Duty ratio: 60%
Input clock rising/falling time	t_{cr} t_{cf}	X0	—	—	—	8	ns	$t_{cr} + t_{cf}$

• Clock Input Timings

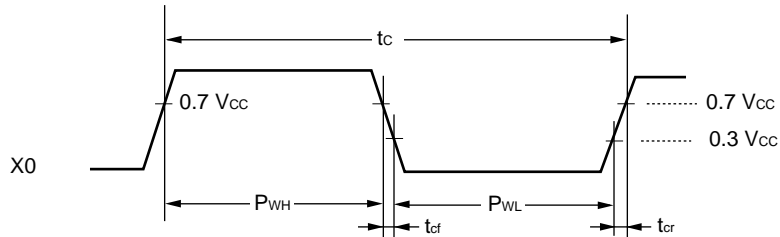

• Clock Conditions

When a crystal or ceramic resonator is used

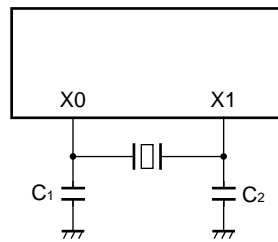

$C_1 = C_2 = 10\text{ pF}$

Select the optimum capacity value for the resonator.

When an external clock is used

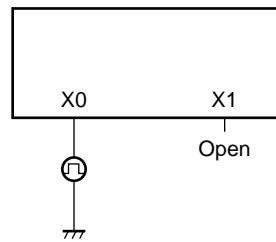

• Relationship between Clock Frequency and Power Supply Voltage

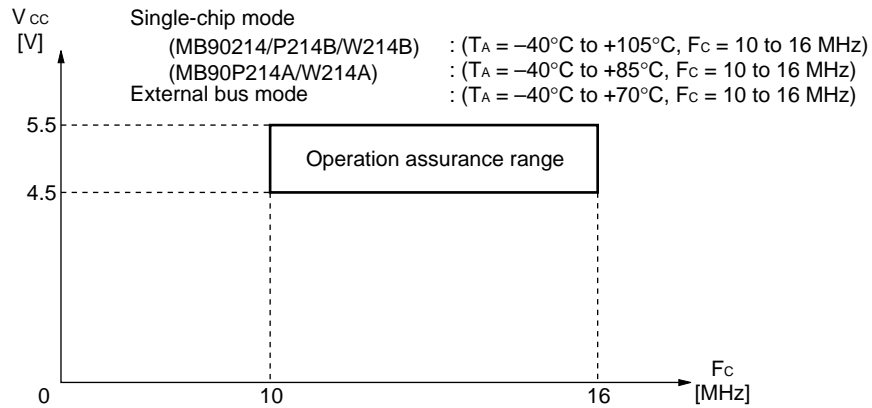

(2) Clock Output Timing Standards

External mode: ($V_{CC} = +4.5$ to $+5.5$ V, $V_{SS} = 0.0$ V, $T_A = -40^\circ\text{C}$ to $+70^\circ\text{C}$)

Parameter	Symbol	Pin name	Condition	Value			Unit	Remarks
				Min.	Typ.	Max.		
Machine cycle time	t_{CYC}	CLK	Load condition: 80 pF	62.5	—	1600	ns	*
CLK $\uparrow \rightarrow$ CLK \downarrow	t_{CHCL}			$t_{CYC}/2 - 20$	—	$t_{CYC}/2$	ns	

* : $t_{CYC} = n/F_c$, n gear ratio (1, 2, 4, 16)

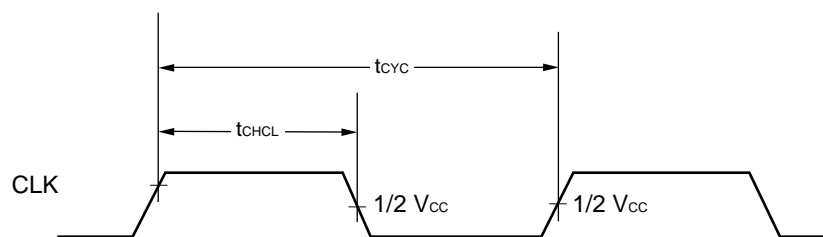

MB90210 Series

(3) Recommended Resonator Manufacturers

• Sample Application of Piezoelectric Resonator (FAR Series)

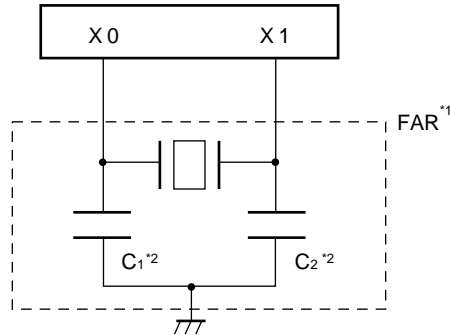

*1: Fujitsu Acoustic Resonator

FAR part number (built-in capacitor type)	Frequency	Initial deviation of FAR frequency ($T_A = +25^\circ\text{C}$)	Temperature characteristics of FAR frequency ($T_A = -20^\circ\text{C}$ to $+60^\circ\text{C}$)	Load capacitance*2
FAR-C4C F-1 6000-□02	16.00	$\pm 0.5\%$	$\pm 0.5\%$	Built-in
FAR-C4C F-1 6000-□12		$\pm 0.5\%$	$\pm 0.5\%$	

Inquiry: FUJITSU LIMITED

(4) Reset and Hardware Standby Input Standards

Single-chip mode MB90214/P214B/W214B : ($V_{CC} = +4.5\text{ V}$ to $+5.5\text{ V}$, $V_{SS} = 0.0\text{ V}$, $T_A = -40^\circ\text{C}$ to $+105^\circ\text{C}$)

MB90P214A/W214A : ($V_{CC} = +4.5\text{ V}$ to $+5.5\text{ V}$, $V_{SS} = 0.0\text{ V}$, $T_A = -40^\circ\text{C}$ to $+85^\circ\text{C}$)

External bus mode : ($V_{CC} = +4.5\text{ V}$ to $+5.5\text{ V}$, $V_{SS} = 0.0\text{ V}$, $T_A = -40^\circ\text{C}$ to $+70^\circ\text{C}$)

Parameter	Symbol	Pin name	Condition	Value			Unit	Remarks
				Min.	Typ.	Max.		
Reset input time	t_{RSTL}	$\overline{\text{RST}}$	—	5 t_{CYC}	—	—	ns	
Hardware standby input time	t_{HSTL}	$\overline{\text{HST}}$		5 t_{CYC}	—	—	ns	*

* : The machine cycle (t_{CYC}) at hardware standby input is set to 1/16 divided oscillation.

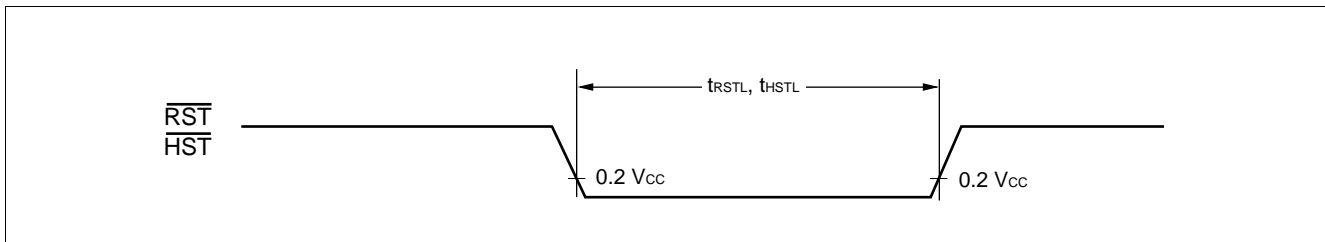

(5) Power on Supply Specifications (Power-on Reset)

Single-chip mode MB90214/P214B/W214B : ($V_{CC} = +4.5\text{ V to }+5.5\text{ V}$, $V_{SS} = 0.0\text{ V}$, $T_A = -40^\circ\text{C to }+105^\circ\text{C}$)
 MB90P214A/W214A : ($V_{CC} = +4.5\text{ V to }+5.5\text{ V}$, $V_{SS} = 0.0\text{ V}$, $T_A = -40^\circ\text{C to }+85^\circ\text{C}$)
 External bus mode : ($V_{CC} = +4.5\text{ V to }+5.5\text{ V}$, $V_{SS} = 0.0\text{ V}$, $T_A = -40^\circ\text{C to }+70^\circ\text{C}$)

Parameter	Symbol	Pin name	Condition	Value			Unit	Remarks
				Min.	Typ.	Max.		
Power supply rising time	t_R	V_{CC}	—	—	—	30	ms	*
Power supply cut-off time	t_{OFF}	V_{CC}	—	1	—	—	ms	

* : Before the power rising, V_{CC} must be less than +0.2 V.

Notes: • The above specifications are for the power-on reset.

- Always apply power-on reset using these specifications, regardless of whether or not the power-on reset is needed.
- There are some internal registers (such as STBYC) which are only initialized by the power-on reset.

• Power-on Reset

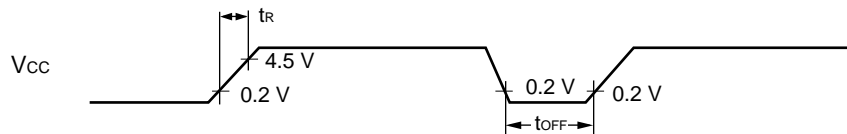

Note: Caution on switching power supply

Abrupt change of supply voltage may initiate power-on reset, even if the above requirements are not met. It is, therefore, recommended to power up gradually during the instantaneous change of power supply as shown in the figure below.

• Changing Power Supply

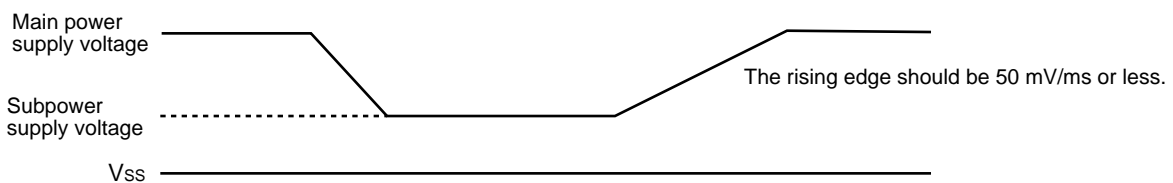

MB90210 Series

(6) Bus Read Timing

($V_{CC} = +4.5$ to $+5.5$ V, $V_{SS} = 0.0$ V, $T_A = -40^\circ\text{C}$ to $+70^\circ\text{C}$)

Parameter	Symbol	Pin name	Condition	Value		Unit	Remarks
				Min.	Max.		
Valid address $\rightarrow \overline{\text{RD}} \downarrow$ time	t_{AVRL}	A23 to A00	Load condition: 80 pF	$t_{\text{CYC}}/2 - 20$	—	ns	
$\overline{\text{RD}}$ pulse width	t_{RLRH}	RD		$t_{\text{CYC}} - 25$	—	ns	
$\overline{\text{RD}} \downarrow \rightarrow$ valid data input	t_{RLDV}	D15 to D00		—	$t_{\text{CYC}} - 30$	ns	
$\overline{\text{RD}} \uparrow \rightarrow$ data hold time	t_{RHDX}			0	—	ns	
Valid address \rightarrow valid data input	t_{AVDV}			—	$3 t_{\text{CYC}}/2 - 40$	ns	
$\overline{\text{RD}} \uparrow \rightarrow$ address valid time	t_{RHAX}	A23 to A00		$t_{\text{CYC}}/2 - 20$	—	ns	
Valid address \rightarrow CLK \uparrow time	t_{AVCH}	A23 to A00 CLK		$t_{\text{CYC}}/2 - 25$	—	ns	
$\overline{\text{RD}} \downarrow \rightarrow$ CLK \downarrow time	t_{RLCL}	$\overline{\text{RD}}$, CLK		$t_{\text{CYC}}/2 - 25$	—	ns	

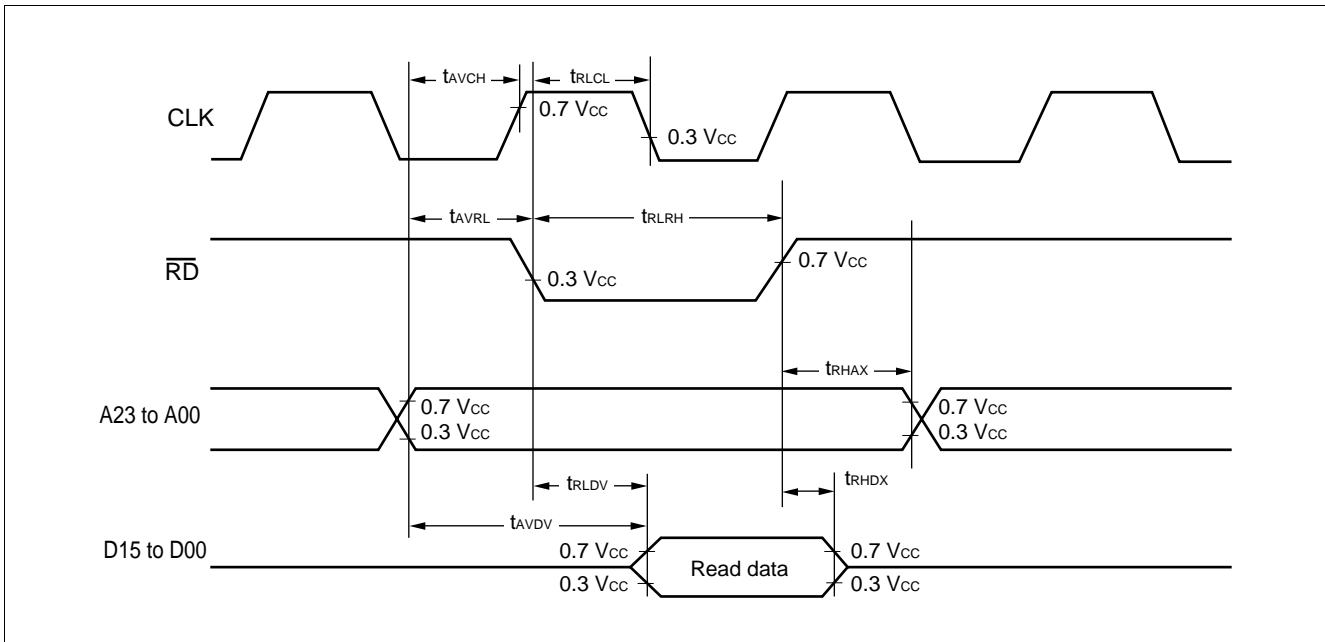

(7) Bus Write Timing

($V_{CC} = +4.5$ to $+5.5$ V, $V_{SS} = 0.0$ V, $T_A = -40^\circ\text{C}$ to $+70^\circ\text{C}$)

Parameter	Symbol	Pin name	Condition	Value		Unit	Remarks
				Min.	Max.		
Valid address $\rightarrow \overline{WR} \downarrow$ time	t_{AVWL}	A23 to A00	Load condition: 80 pF	$t_{CYC}/2 - 20$	—	ns	
$\overline{WR} \downarrow$ pulse width	t_{WLWH}	$\overline{WRL}, \overline{WRH}$		$t_{CYC} - 25$	—	ns	
Valid data output $\rightarrow \overline{WR} \uparrow$ time	t_{DVWH}	D15 to D00		$t_{CYC} - 40$	—	ns	
$\overline{WR} \uparrow \rightarrow$ data hold time	t_{WHDX}			$t_{CYC}/2 - 20$	—	ns	
$\overline{WR} \uparrow \rightarrow$ address valid time	t_{WHAX}	A23 to A00		$t_{CYC}/2 - 20$	—	ns	
$\overline{WR} \downarrow \rightarrow$ CLK \downarrow time	t_{WLCH}	$\overline{WRL}, \overline{WRH}, \text{CLK}$		$t_{CYC}/2 - 25$	—	ns	

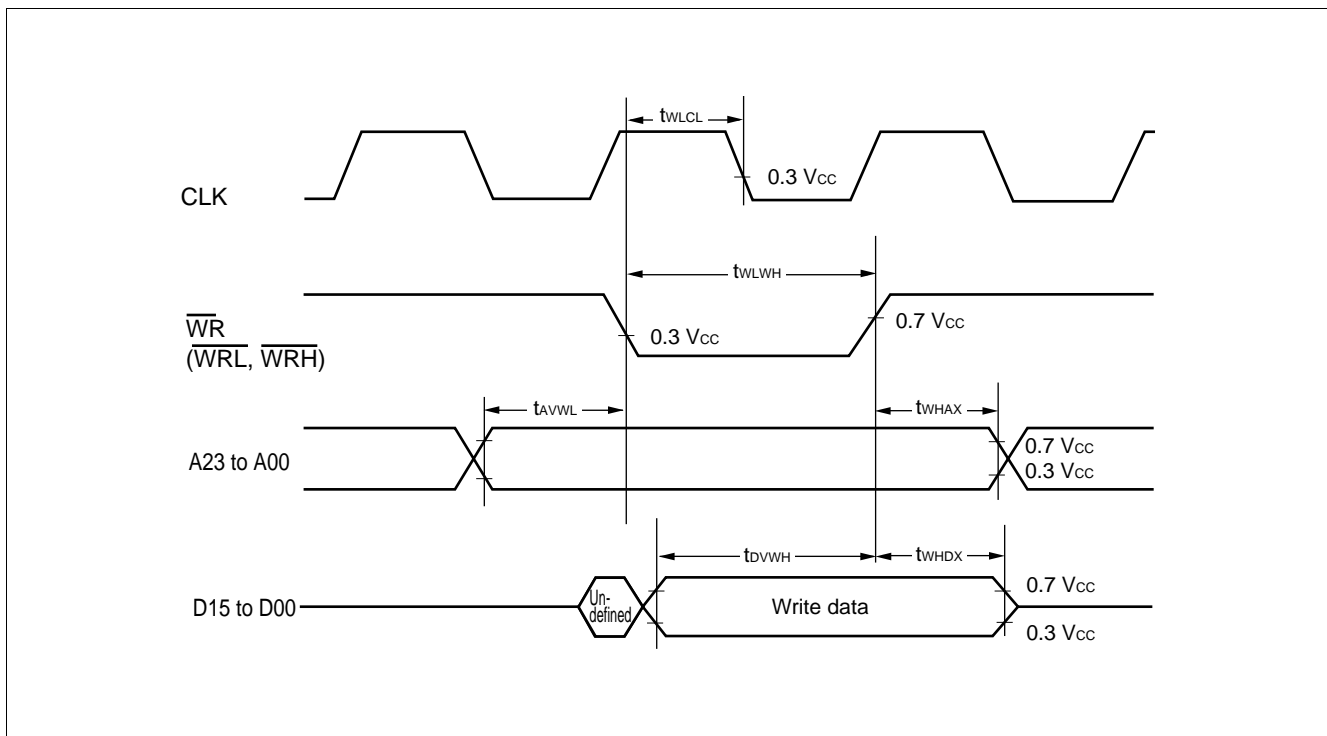

MB90210 Series

(8) Ready Signal Input Timing

($V_{CC} = +4.5$ to $+5.5$ V, $V_{SS} = 0.0$ V, $T_A = -40^\circ\text{C}$ to $+70^\circ\text{C}$)

Parameter	Symbol	Pin name	Condition	Value		Unit	Remarks
				Min.	Max.		
RDY setup time	t_{RYHS}	RDY	Load condition: 80 pF	40	—	ns	
RDY hold time	t_{RYHH}			0	—	ns	

Note: Use the auto-ready function if the RDY setup time is insufficient.

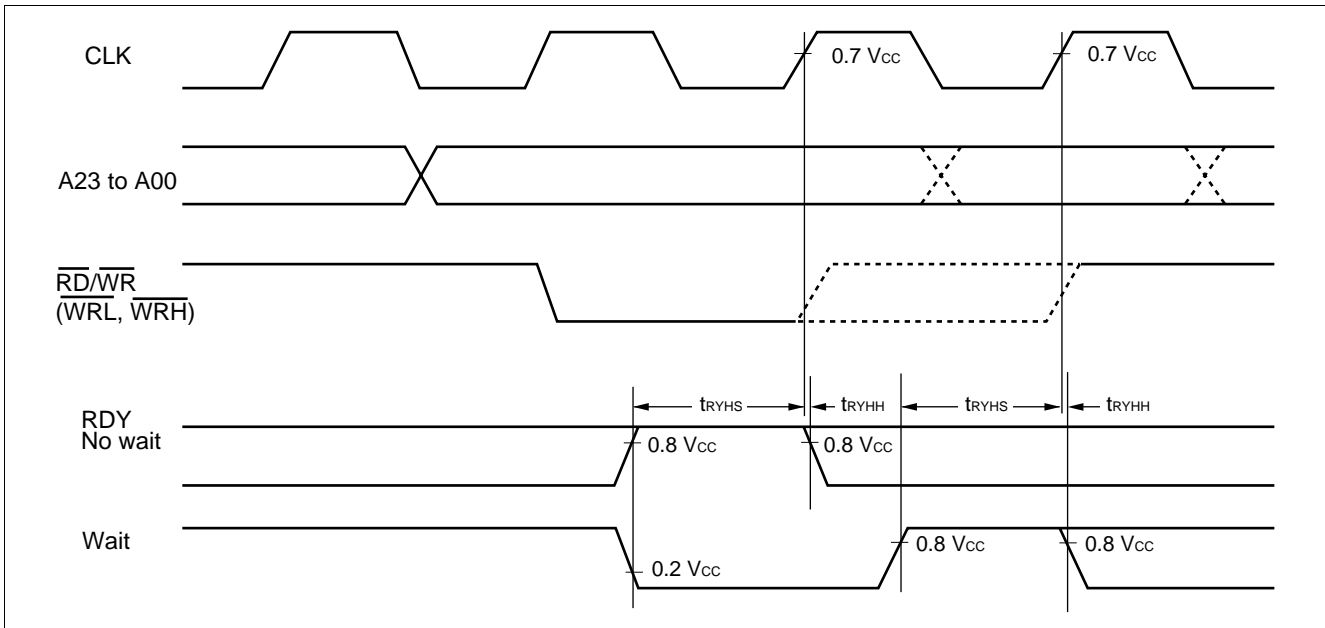

(9) Hold Timing

($V_{CC} = +4.5$ to $+5.5$ V, $V_{SS} = 0.0$ V, $T_A = -40^\circ\text{C}$ to $+70^\circ\text{C}$)

Parameter	Symbol	Pin name	Condition	Value		Unit	Remarks
				Min.	Max.		
Pin floating $\rightarrow \overline{\text{HAK}} \downarrow$ time	t_{XHAL}	$\overline{\text{HAK}}$	Load condition: 80 pF	30	t_{CYC}	ns	
$\overline{\text{HAK}} \uparrow \rightarrow$ pin valid time	t_{HAHV}			t_{CYC}	$2t_{CYC}$	ns	

Note: It takes at least one cycle for $\overline{\text{HAK}}$ to vary after HRQ is fetched.

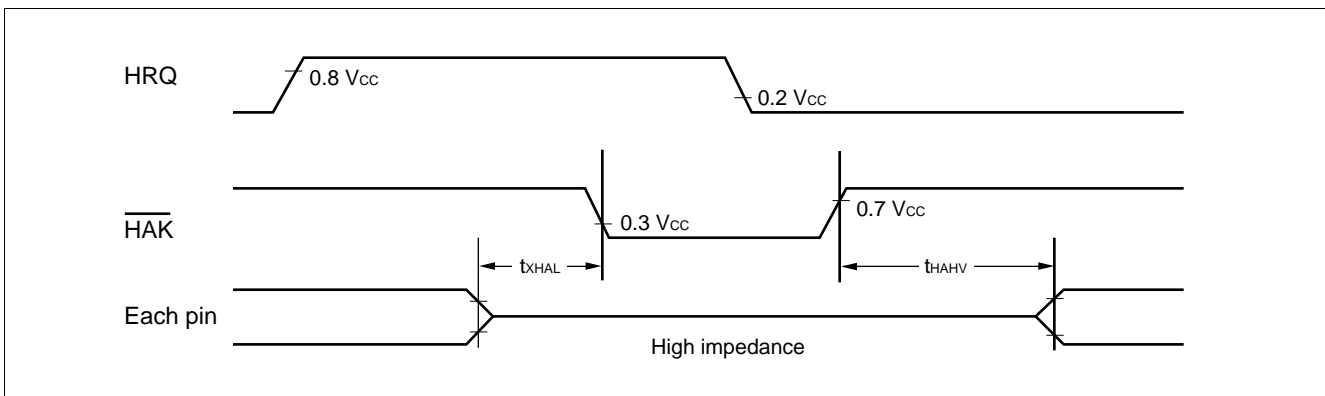

(10) UART Timing

Single-chip mode MB90214/P214B/W214B : ($V_{CC} = +4.5\text{ V to }+5.5\text{ V}$, $V_{SS} = 0.0\text{ V}$, $T_A = -40^\circ\text{C to }+105^\circ\text{C}$)
 MB90P214A/W214A : ($V_{CC} = +4.5\text{ V to }+5.5\text{ V}$, $V_{SS} = 0.0\text{ V}$, $T_A = -40^\circ\text{C to }+85^\circ\text{C}$)
 External bus mode : ($V_{CC} = +4.5\text{ V to }+5.5\text{ V}$, $V_{SS} = 0.0\text{ V}$, $T_A = -40^\circ\text{C to }+70^\circ\text{C}$)

Parameter	Symbol	Pin name	Condition	Value		Unit	Remarks
				Min.	Max.		
Serial clock cycle time	t _{SCYC}	—	Load condition: 80 pF	8 t _{CYC}	—	ns	Internal shift clock mode output pin
SCLK ↓ → SOUT delay time	t _{SLOV}			-80	80	ns	
Valid SIN → SCLK ↑	t _{IVSH}			100	—	ns	
SCLK ↑ → Valid SIN hold time	t _{SHIX}			60	—	ns	
Serial clock "H" pulse width	t _{SHSL}			4 t _{CYC}	—	ns	External shift clock mode output pin
Serial clock "L" pulse width	t _{SLSH}			4 t _{CYC}	—	ns	
SCLK ↓ → SOUT delay time	t _{SLOV}			—	150	ns	
Valid SIN → SCLK ↑	t _{IVSH}			60	—	ns	
SCLK ↑ → Valid SIN hold time	t _{SHIX}			60	—	ns	

Notes: • These AC characteristics assume the CLK synchronous mode.
 • t_{CYC} is the machine cycle (unit: ns).

MB90210 Series

• Internal Shift Clock Mode

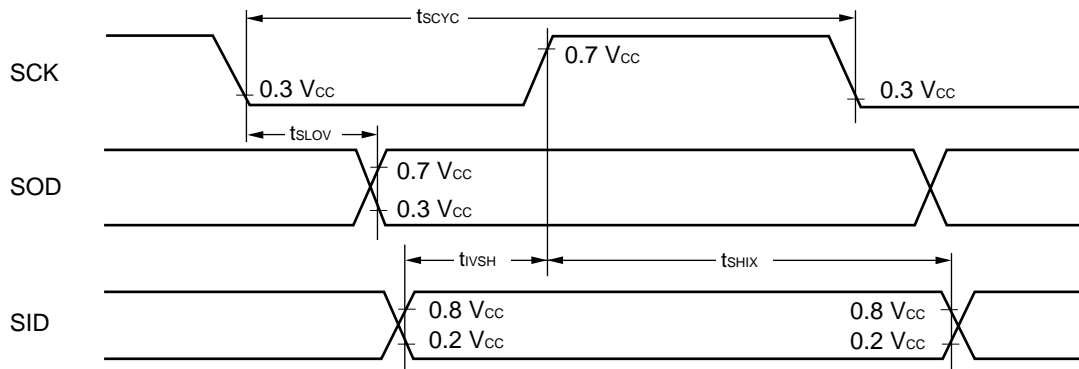

• External Shift Clock Mode

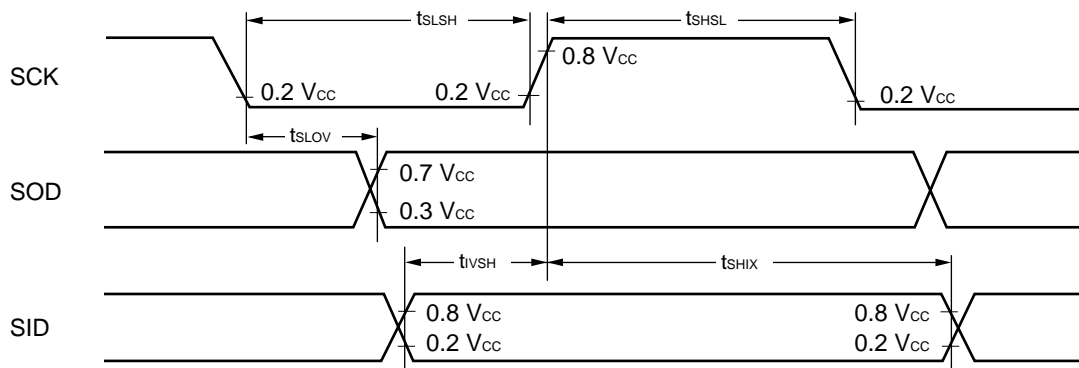

(11) Resource Input Timing

Single-chip mode MB90214/P214B/W214B : ($V_{CC} = +4.5\text{ V to }+5.5\text{ V}$, $V_{SS} = 0.0\text{ V}$, $T_A = -40^\circ\text{C to }+105^\circ\text{C}$)
 MB90P214A/W214A : ($V_{CC} = +4.5\text{ V to }+5.5\text{ V}$, $V_{SS} = 0.0\text{ V}$, $T_A = -40^\circ\text{C to }+85^\circ\text{C}$)
 External bus mode : ($V_{CC} = +4.5\text{ V to }+5.5\text{ V}$, $V_{SS} = 0.0\text{ V}$, $T_A = -40^\circ\text{C to }+70^\circ\text{C}$)

Parameter	Symbol	Pin name	Condition	Value			Unit	Remarks
				Min.	Typ.	Max.		
Input pulse width	t_{TIWH} t_{TIWL}	TIN0 to TIN3	Load condition: 80 pF	4 t_{CYC}	—	—	ns	External event count input mode
				2 t_{CYC}	—	—		Trigger input/ Gate input mode
		TIN4 to TIN7		2 t_{CYC}	—	—	ns	Gate input mode
		PWC0 to PWC3		2 t_{CYC}	—	—	ns	
		INT0 to INT3		3 t_{CYC}	—	—	ns	
		ATG		2 t_{CYC}	—	—	ns	
	t_{WIWL}	\overline{WI}		4 t_{CYC}	—	—	ns	

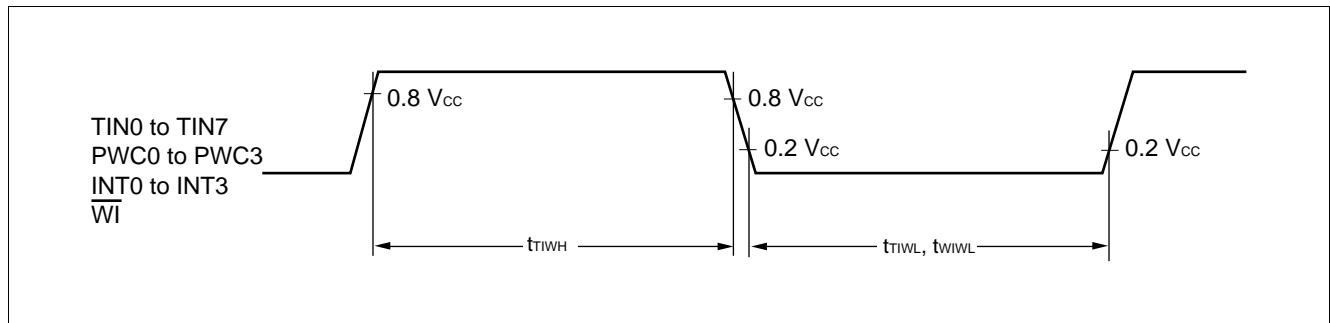

(12) Resource Output Timing

Single-chip mode MB90214/P214B/W214B : ($V_{CC} = +4.5\text{ V to }+5.5\text{ V}$, $V_{SS} = 0.0\text{ V}$, $T_A = -40^\circ\text{C to }+105^\circ\text{C}$)
 MB90P214A/W214A : ($V_{CC} = +4.5\text{ V to }+5.5\text{ V}$, $V_{SS} = 0.0\text{ V}$, $T_A = -40^\circ\text{C to }+85^\circ\text{C}$)
 External bus mode : ($V_{CC} = +4.5\text{ V to }+5.5\text{ V}$, $V_{SS} = 0.0\text{ V}$, $T_A = -40^\circ\text{C to }+70^\circ\text{C}$)

Parameter	Symbol	Pin name	Condition	Value		Unit	Remarks
				Min.	Max.		
CLK $\uparrow \rightarrow$ TOUT transition time	t_{TO}	TOUT0 to TOUT3 PPG POUT0 to POUT3	Load condition: 80 pF	—	30	ns	

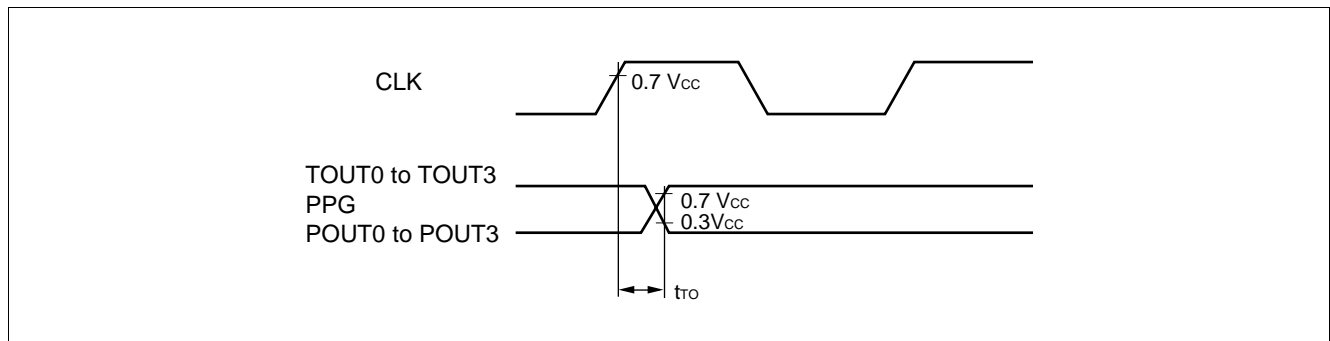

MB90210 Series

5. A/D Converter Electrical Characteristics

Single-chip mode MB90214/P214B/W214B:

($AV_{CC} = V_{CC} = +5.0 \pm 10\%$, $AV_{SS} = V_{SS} = 0.0$ V, $T_A = -40^\circ\text{C}$ to $+105^\circ\text{C}$, $+4.5$ V \leq $AV_{RH} - AV_{RL}$)

Single-chip mode MBP90214A/W214A:

($AV_{CC} = V_{CC} = +5.0 \pm 10\%$, $AV_{SS} = V_{SS} = 0.0$ V, $T_A = -40^\circ\text{C}$ to $+85^\circ\text{C}$, $+4.5$ V \leq $AV_{RH} - AV_{RL}$)

External bus mode:

($AV_{CC} = V_{CC} = +5.0 \pm 10\%$, $AV_{SS} = V_{SS} = 0.0$ V, $T_A = -40^\circ\text{C}$ to $+70^\circ\text{C}$, $+4.5$ V \leq $AV_{RH} - AV_{RL}$)

Parameter	Symbol	Pin name	Condition	Value			Unit	Remarks
				Min.	Typ.	Max.		
Resolution	n	—	—	—	—	10	bit	
Total error	—	—	—	-3.0	—	+3.0	LSB	
Linearity error	—	—	—	-2.0	—	+2.0	LSB	
Differential linearity error	—	—	—	—	—	± 1.5	LSB	
Zero transition voltage	V_{OT}	AN0 to AN7	—	$AV_{RL} - 1.5$	$AV_{RL} + 0.5$	$AV_{RL} + 2.5$	LSB	
Full-scale transition voltage	V_{FST}		—	$AV_{RH} - 3.5$	$AV_{RH} - 1.5$	$AV_{RH} + 0.5$	LSB	
Conversion time	T_{CONV}	—	$t_{CYC} = 62.5$ ns	6.125	—	—	μs	98 machine cycles
Sampling period	T_{SAMP}	—		3.75	—	—	μs	60 machine cycles
Analog port input current	I_{AIN}	AN0 to AN7	—	—	—	± 0.1	μA	
Analog input voltage	V_{AIN}		—	AV_{RL}	—	AV_{RH}	V	
Analog reference voltage	—	AV_{RH}	—	AV_{RL}	—	AV_{CC}	V	
		AV_{RL}	—	AV_{SS}	—	AV_{RH}	V	
Reference voltage supply current	I_R	AV_{RH}	—	—	200	500	μA	
	I_{RH}		—	—	—	5*	μA	
Interchannel disparity	—	AN0 to AN7	—	—	—	4	LSB	

* : The current value applies to the CPU stop mode with the A/D converter inactive ($V_{CC} = AV_{CC} = AV_{RH} = +5.5$ V).

Notes: (1) The smaller the $|AV_{RH} - AV_{RL}|$, the greater the error would become relatively.

(2) Use the output impedance of the external circuit for analog input under the following conditions:

External circuit output impedance < approx. 10 k Ω (Sampling period = 3.75 μs , $t_{CYC} = 62.5$ ns)

(3) Precision values are standard values applicable to sleep mode.

(4) If V_{CC}/AV_{CC} or V_{SS}/AV_{SS} is caused by a noise to drop to below the analog input voltage, the analog input current is likely to increase. In such cases, a bypass capacitor or the like should be provided in the external circuit to suppress the noise.

• Equivalent Circuit of Analog Input Circuit

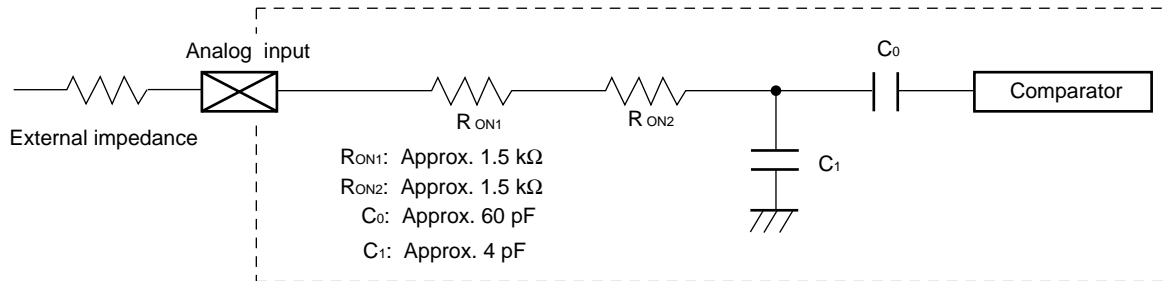

Note: The values shown here are reference values.

6. A/D Converter Glossary

Resolution: Analog changes that are identifiable with the A/D converter

When the number of bits is 10, analog voltage can be divided into $2^{10} = 1024$.

Total error: Difference between actual and logical values. This error is caused by a zero transition error, full-scale transition error, linearity error, differential linearity error, or by noise.

Linearity error: The deviation of the straight line connecting the zero transition point ("00 0000 0000" \leftrightarrow "00 0000 0001") with the full-scale transition point ("11 1111 1111" \leftrightarrow "11 1111 1110") from actual conversion characteristics

Differential linearity error: The deviation of input voltage needed to change the output code by 1 LSB from the theoretical value.

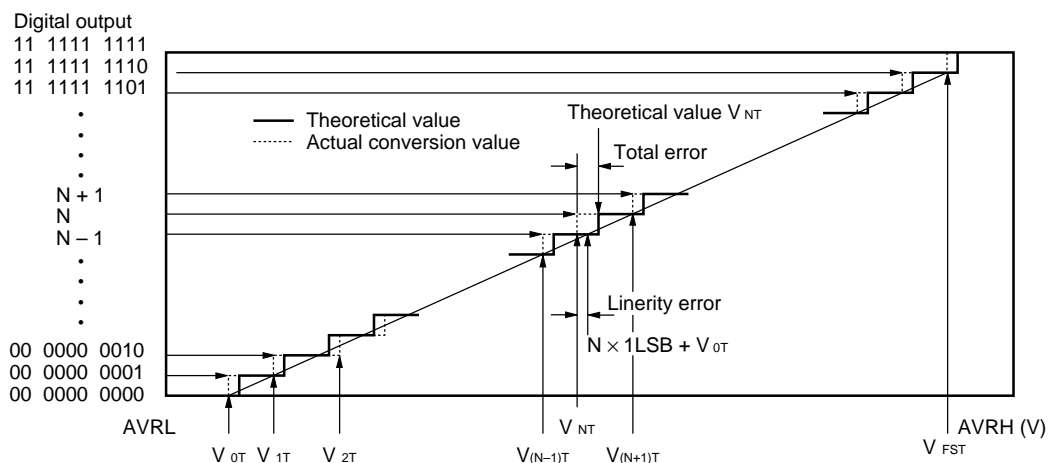

$$\bullet 1LSB = \frac{V_{FST} - V_{0T}}{1022} \quad \bullet 1LSB \text{ theoretical value} = \frac{AV_{RH} - AV_{RL}}{1022}$$

$$\bullet \text{Linearity error} = \frac{V_{NT} - (N \times 1LSB + V_{0T})}{1LSB} \quad \left[\begin{array}{l} N = 0 \text{ to } 1022 \\ V_{NT(N=0)} = V_{0T} \\ V_{NT(N=1022)} = V_{FST} \end{array} \right.$$

$$\bullet \text{Differential linearity error} = \frac{V_{NT} - V_{(N-1)T}}{1LSB} - 1 \quad N = 1 \text{ to } 1022$$

$$\bullet \text{Total error} = \frac{V_{NT} - \{ (N + 0.5) \times 1LSB \text{ theoretical value} \}}{1LSB \text{ theoretical value}} \quad N = 0 \text{ to } 1022$$

MB90210 Series

EXAMPLE CHARACTERISTICS

(1) Power Supply Current

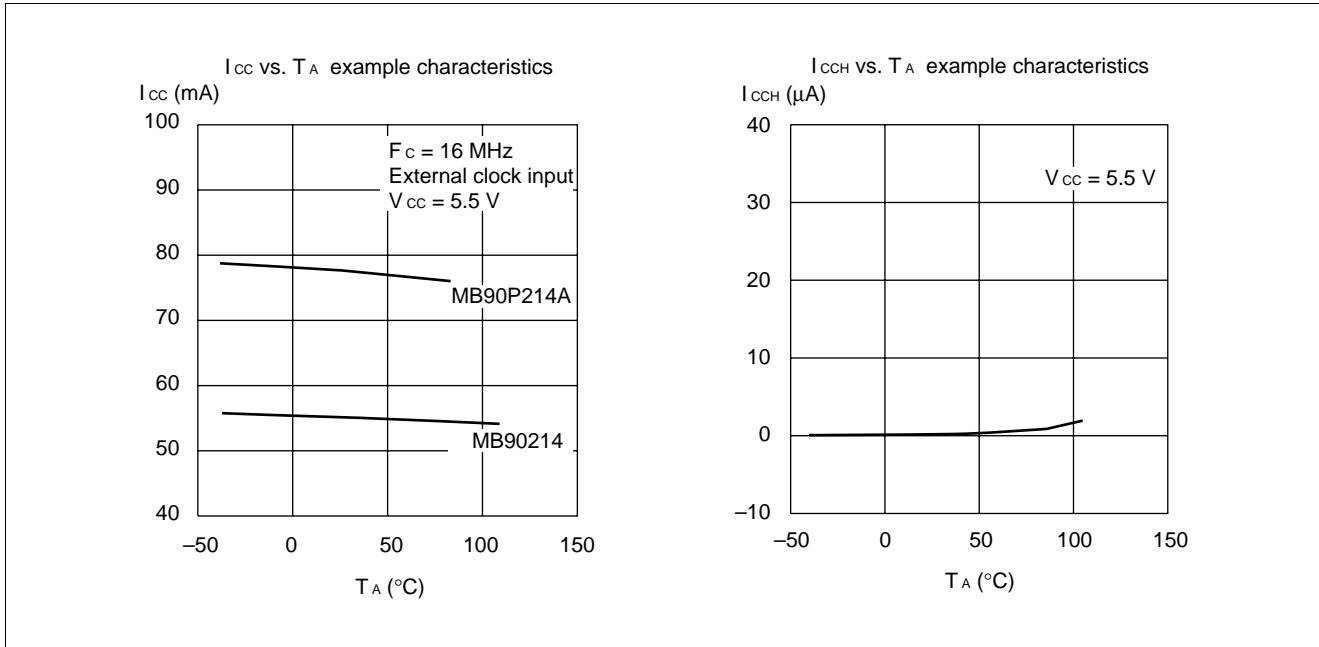

Note: These are not assured value of characteristics but example characteristics.

(2) Output Voltage

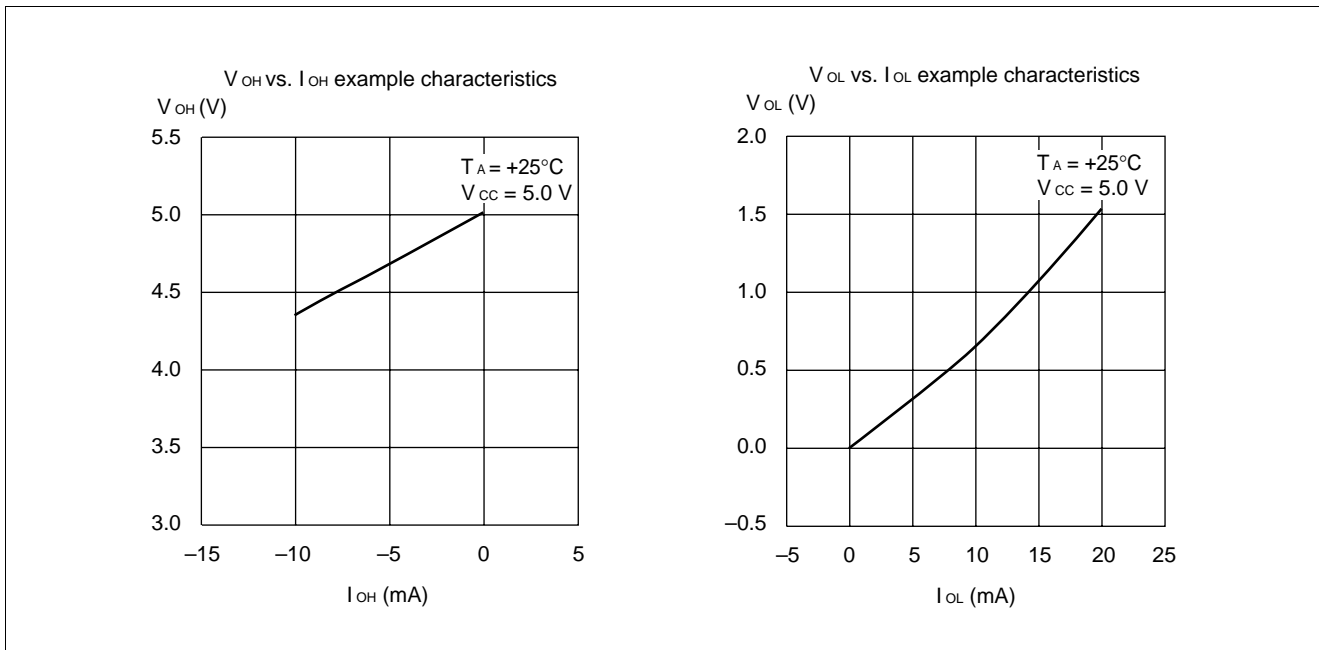

Note: These are not assured value of characteristics but example characteristics.

(3) Pull-up/Pull-down Resistor

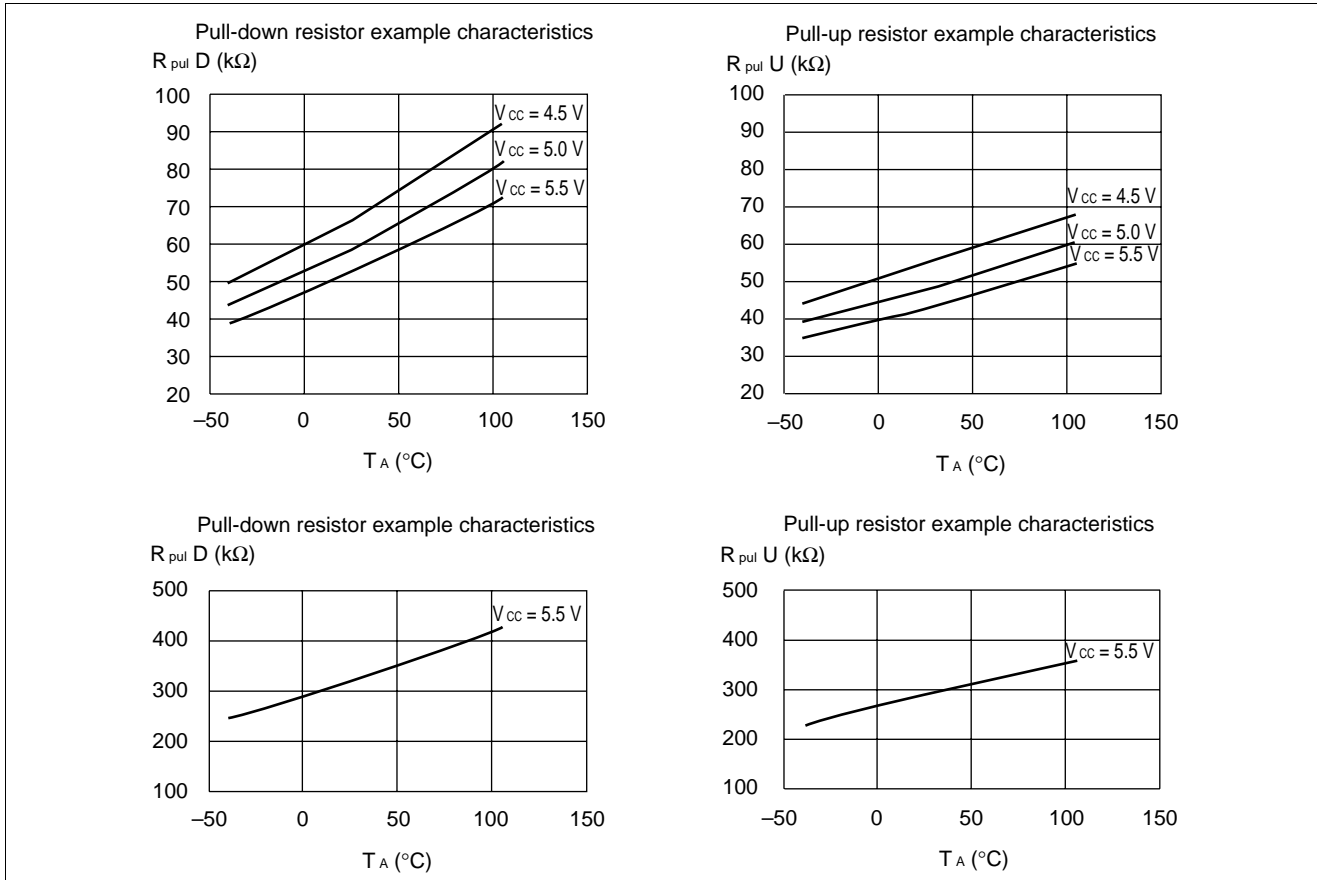

Note: These are not assured value of characteristics but example characteristics.

(4) Analog Filter

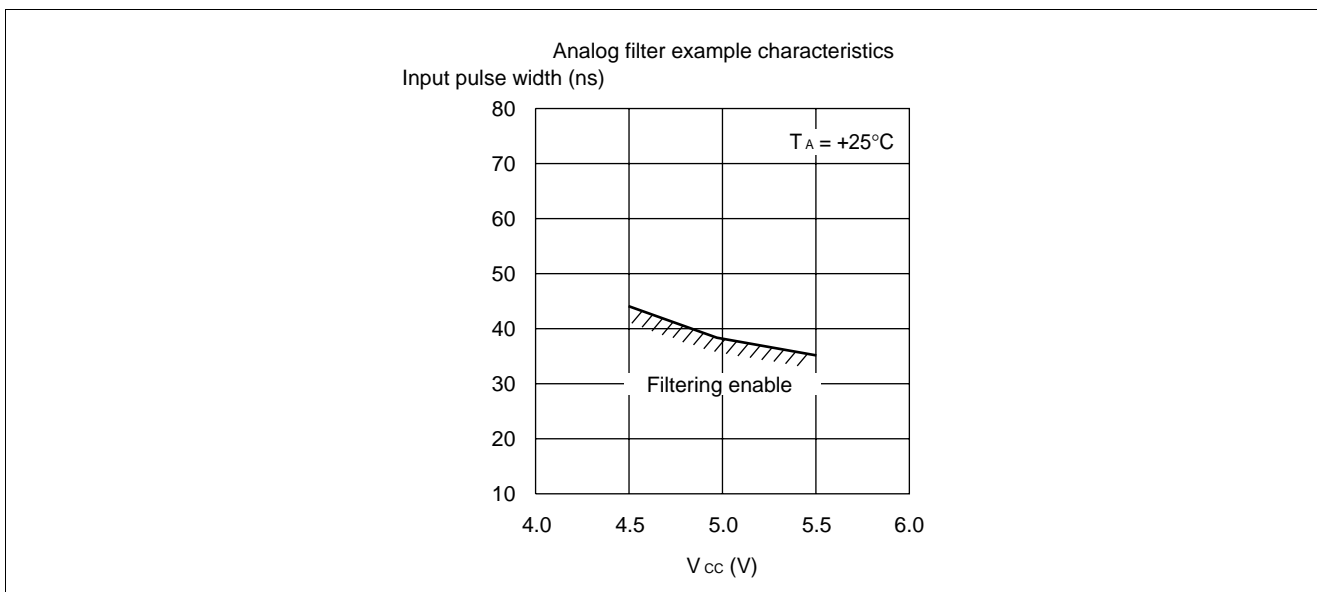

Note: These are not assured value of characteristics but example characteristics.

MB90210 Series

■ INSTRUCTIONS (421 INSTRUCTIONS)

Table 1 Description of Items in Instruction List

Item	Description
Mnemonic	English upper case and symbol: Described directly in assembler code. English lower case: Converted in assembler code. Number of letters after English lower case: Describes bit width in code.
#	Describes number of bytes.
~	Describes number of cycles. For other letters in other items, refer to table 4.
B	Describes correction value for calculating number of actual states. Number of actual states is calculated by adding value in the ~-section.
Operation	Describes operation of instructions.
LH	Describes a special operation to 15 bits to 08 bits of the accumulator. Z : Transfer 0. X : Sign-extend and transfer. - : No transmission
AH	Describes a special operation to the upper 16-bit of the accumulator. * : Transmit from AL to AH. - : No transfer. Z : Transfer 00 _H to AH. X : Sign-extend AL and transfer 00 _H or FF _H to AH.
I	Describes status of I (interrupt enable), S (stack), T (sticky bit), N (negative), Z (zero), V (overflow), and C (carry) flags. * : Changes after execution of instruction. - : No changes. S : Set after execution of instruction. R : Reset after execution of instruction.
S	
T	
N	
Z	
V	
C	
RMW	Describes whether or not the instruction is a read-modify-write type (a data is read out from memory etc. in single cycle, and the result is written into memory etc.). * : Read-modify-write instruction - : Not read-modify-write instruction Note: Not used to addresses having different functions for reading and writing operations.

Table 2 Description of Symbols in Instruction Table

Item	Description
A	32-bit accumulator The bit length is dependent on the instructions to be used. Byte : Lower 8-bit of AL Word :16-bit of AL Long : AL: 32-bit of AH
AH	Upper 16-bit of A
AL	Lower 16-bit of A
SP	Stack pointer (USP or SSP)
PC	Program counter
SPCU	Stack pointer upper limited register
SPCL	Stack pointer lower limited register
PCB	Program bank register
DTB	Data bank register
ADB	Additional data bank register
SSB	System stack bank register
USB	User stack bank register
SPB	Current stack bank register (SSB or USB)
DPR	Direct page register
brg1	DTB, ADB, SSB, USB, DPR, PCB
brg2	DTB, ADB, SSB, USB, DPR
Ri	R0, R1, R2, R3, R4, R5, R6, R7
RWi	RW0, RW1, RW2, RW3, RW4, RW5, RW6, RW7
RWj	RW0, RW1, RW2, RW3
RLi	RL0, RL1, RL2, RL3
dir addr16 addr24 ad24 0 to 15 ad24 16 to 23	Specify shortened direct address. Specify direct address. Specify physical direct address. bit0 to bit15 of addr24 bit16 to bit 23 of addr24
io	I/O area (000000 _H to 0000FF _H)
#imm4 #imm8 #imm16 #imm32 ext (imm8)	4-bit immediate data 8-bit immediate data 16-bit immediate data 32-bit immediate data 16-bit data calculated by sign-extending an 8-bit immediate data
disp8 disp16	8-bit displacement 16-bit displacement
bp	Bit offset value
vct4 vct8	Vector number (0 to 15) Vector number (0 to 255)
()b	Bit address
rel ear eam	Specify PC relative branch. Specify effective address (code 00 to 07). Specify effective address (code 08 to 1F).
rlst	Register allocation

MB90210 Series

Table 3 Effective Address Field

Code	Symbol			Address type	Number of bytes in address extension block*
00 01 02 03 04 05 06 07	R0 R1 R2 R3 R4 R5 R6 R7	RW0 RW1 RW2 RW3 RW4 RW5 RW6 RW7	RL0 (RL0) RL1 (RL1) RL2 (RL2) RL3 (RL3)	Register direct "ea" corresponds to byte, word, and long word from left respectively.	—
08 09 0A 0B	@RW0 @RW1 @RW2 @RW3			Register indirect	0
0C 0D 0E 0F	@RW0 + @RW1 + @RW2 + @RW3 +			Register indirect with post increment	0
10 11 12 13 14 15 16 17	@RW0 + disp8 @RW1 + disp8 @RW2 + disp8 @RW3 + disp8 @RW4 + disp8 @RW5 + disp8 @RW6 + disp8 @RW7 + disp8			Register indirect with 8-bit displacement	1
18 19 1A 1B	@RW0 + disp16 @RW1 + disp16 @RW2 + disp16 @RW3 + disp16			Register indirect with 16-bit displacement	2
1C 1D 1E 1F	@RW0 + RW7 @RW1 + RW7 @PC + disp16 addr16			Register indirect with index Register indirect with index PC indirect with 16-bit displacement Direct address	0 0 2 2

Note: Number of bytes for address extension corresponds to "+" in the # (number of bytes) part in the instruction table.

Table 4 Number of Execution Cycles in Addressing Modes

Code	Operand	(a)*
		Number of execution cycles for addressing modes
00 to 07	Ri RWi RLi	Listed in instruction table
08 to 0B	@RWj	1
0C to 0F	@RWj +	4
10 to 17	@RWi + disp8	1
18 to 1B	@RWj + disp16	1
1C	@RW0 + RW7	2
1D	@RW1 + RW7	2
1E	@PC + disp16	2
1F	addr16	1

Note: (a) is used for ~ (number of cycles) and B (correction value) in instruction table.

Table 5 Correction Value for Number of Cycles for Calculating Actual Number of Cycles

Operand	(b)*	(c)*	(d)*
	byte	word	long
Internal register	+0	+0	+0
Internal RAM even address	+0	+0	+0
Internal RAM odd address	+0	+1	+2
Other than internal RAM even address	+1	+1	+2
Other than internal RAM odd address	+1	+3	+6
External data bus 8-bit	+1	+3	+6

Notes: (b), (c), (d) is used for ~ (number of cycles) and B (correction value) in instruction table.

MB90210 Series

Table 6 Transmission Instruction (Byte) [50 Instructions]

Mnemonic	#	~	B	Operation	LH	AH	I	S	T	N	Z	V	C	RMW
MOV A, dir	2	2	(b)	byte (A) ← (dir)	Z	*	-	-	-	*	*	-	-	-
MOV A, addr16	3	2	(b)	byte (A) ← (addr16)	Z	*	-	-	-	*	*	-	-	-
MOV A, Ri	1	1	0	byte (A) ← (Ri)	Z	*	-	-	-	*	*	-	-	-
MOV A, ear	2	1	0	byte (A) ← (ear)	Z	*	-	-	-	*	*	-	-	-
MOV A, eam	2 +	2 + (a)	(b)	byte (A) ← (eam)	Z	*	-	-	-	*	*	-	-	-
MOV A, io	2	2	(b)	byte (A) ← (io)	Z	*	-	-	-	*	*	-	-	-
MOV A, #imm8	2	2	0	byte (A) ← imm8	Z	*	-	-	-	*	*	-	-	-
MOV A, @A	2	2	(b)	byte (A) ← ((A))	Z	-	-	-	-	*	*	-	-	-
MOV A, @RLi + disp8	3	6	(b)	byte (A) ← ((RLi) + disp8)	Z	*	-	-	-	*	*	-	-	-
MOV A, @SP + disp8	3	3	(b)	byte (A) ← ((SP) + disp8)	Z	*	-	-	-	*	*	-	-	-
MOVP A, addr24	5	3	(b)	byte (A) ← (addr24)	Z	*	-	-	-	*	*	-	-	-
MOVP A, @A	2	2	(b)	byte (A) ← ((A))	Z	-	-	-	-	*	*	-	-	-
MOVN A, #imm4	1	1	0	byte (A) ← imm4	Z	*	-	-	-	R	*	-	-	-
MOVX A, dir	2	2	(b)	byte (A) ← (dir)	X	*	-	-	-	*	*	-	-	-
MOVX A, addr16	3	2	(b)	byte (A) ← (addr16)	X	*	-	-	-	*	*	-	-	-
MOVX A, Ri	2	1	0	byte (A) ← (Ri)	X	*	-	-	-	*	*	-	-	-
MOVX A, ear	2	1	0	byte (A) ← (ear)	X	*	-	-	-	*	*	-	-	-
MOVX A, eam	2 +	2 + (a)	(b)	byte (A) ← (eam)	X	*	-	-	-	*	*	-	-	-
MOVX A, io	2	2	(b)	byte (A) ← (io)	X	*	-	-	-	*	*	-	-	-
MOVX A, #imm8	2	2	0	byte (A) ← imm8	X	*	-	-	-	*	*	-	-	-
MOVX A, @A	2	2	(b)	byte (A) ← ((A))	X	-	-	-	-	*	*	-	-	-
MOVX A, @RWi + disp8	2	3	(b)	byte (A) ← ((RWi) + disp8)	X	*	-	-	-	*	*	-	-	-
MOVX A, @RLi + disp8	3	6	(b)	byte (A) ← ((RLi) + disp8)	X	*	-	-	-	*	*	-	-	-
MOVX A, @SP + disp8	3	3	(b)	byte (A) ← ((SP) + disp8)	X	*	-	-	-	*	*	-	-	-
MOVPX A, addr24	5	3	(b)	byte (A) ← (addr24)	X	*	-	-	-	*	*	-	-	-
MOVPX A, @A	2	2	(b)	byte (A) ← ((A))	X	-	-	-	-	*	*	-	-	-
MOV dir, A	2	2	(b)	byte (dir) ← (A)	-	-	-	-	-	*	*	-	-	-
MOV addr16, A	3	2	(b)	byte (addr16) ← (A)	-	-	-	-	-	*	*	-	-	-
MOV Ri, A	1	1	0	byte (Ri) ← (A)	-	-	-	-	-	*	*	-	-	-
MOV ear, A	2	2	0	byte (ear) ← (A)	-	-	-	-	-	*	*	-	-	-
MOV eam, A	2 +	2 + (a)	(b)	byte (eam) ← (A)	-	-	-	-	-	*	*	-	-	-
MOV io, A	2	2	(b)	byte (io) ← (A)	-	-	-	-	-	*	*	-	-	-
MOV @RLi + disp8, A	3	6	(b)	byte ((RLi) + disp8) ← (A)	-	-	-	-	-	*	*	-	-	-
MOV @SP + disp8, A	3	3	(b)	byte ((SP) + disp8) ← (A)	-	-	-	-	-	*	*	-	-	-
MOVP addr24, A	5	3	(b)	byte (addr24) ← (A)	-	-	-	-	-	*	*	-	-	-
MOV Ri, ear	2	2	0	byte (Ri) ← (ear)	-	-	-	-	-	*	*	-	-	-
MOV Ri, eam	2 +	3 + (a)	(b)	byte (Ri) ← (eam)	-	-	-	-	-	*	*	-	-	-
MOVP @A, Ri	2	3	(b)	byte ((A)) ← (Ri)	-	-	-	-	-	*	*	-	-	-
MOV ear, Ri	2	3	0	byte (ear) ← (Ri)	-	-	-	-	-	*	*	-	-	-
MOV eam, Ri	2 +	3 + (a)	(b)	byte (eam) ← (Ri)	-	-	-	-	-	*	*	-	-	-
MOV Ri, #imm8	2	2	0	byte (Ri) ← imm8	-	-	-	-	-	*	*	-	-	-
MOV io, #imm8	3	3	(b)	byte (io) ← imm8	-	-	-	-	-	-	-	-	-	-
MOV dir, #imm8	3	3	(b)	byte (dir) ← imm8	-	-	-	-	-	-	-	-	-	-
MOV ear, #imm8	3	2	0	byte (ear) ← imm8	-	-	-	-	-	*	*	-	-	-
MOV eam, #imm8	3 +	2 + (a)	(b)	byte (eam) ← imm8	-	-	-	-	-	-	-	-	-	-
MOV @AL, AH	2	2	(b)	byte ((A)) ← (AH)	-	-	-	-	-	*	*	-	-	-
XCH A, ear	2	3	0	byte (A) ↔ (ear)	Z	-	-	-	-	-	-	-	-	-
XCH A, eam	2 +	3 + (a)	2 × (b)	byte (A) ↔ (eam)	Z	-	-	-	-	-	-	-	-	-
XCH Ri, ear	2	4	0	byte (Ri) ↔ (ear)	-	-	-	-	-	-	-	-	-	-
XCH Ri, eam	2 +	5 + (a)	2 × (b)	byte (Ri) ↔ (eam)	-	-	-	-	-	-	-	-	-	-

Note: For (a) and (b), refer to “Table 4 Number of Execution Cycles in Addressing Modes” and “Table 5 Correction Values for Number of Cycles for Calculating Actual Number of Cycles.”

Table 7 Transmission Instruction (Word) [40 Instructions]

Mnemonic	#	~	B	Operation	LH	AH	I	S	T	N	Z	V	C	RMW
MOVW A, dir	2	2	(c)	word (A) ← (dir)	—	*	—	—	—	*	*	—	—	—
MOVW A, addr16	3	2	(c)	word (A) ← (addr16)	—	*	—	—	—	*	*	—	—	—
MOVW A, SP	1	2	0	word (A) ← (SP)	—	*	—	—	—	*	*	—	—	—
MOVW A, RWi	1	1	0	word (A) ← (RWi)	—	*	—	—	—	*	*	—	—	—
MOVW A, ear	2	1	0	word (A) ← (ear)	—	*	—	—	—	*	*	—	—	—
MOVW A, eam	2 +	2 + (a)	(c)	word (A) ← (eam)	—	*	—	—	—	*	*	—	—	—
MOVW A, io	2	2	(c)	word (A) ← (io)	—	*	—	—	—	*	*	—	—	—
MOVW A, @A	2	2	(c)	word (A) ← ((A))	—	—	—	—	—	*	*	—	—	—
MOVW A, #imm16	3	2	0	word (A) ← imm16	—	*	—	—	—	*	*	—	—	—
MOVW A, @RWi + disp8	2	3	(c)	word (A) ← ((RWi) + disp8)	—	*	—	—	—	*	*	—	—	—
MOVW A, @RLi + disp8	3	6	(c)	word (A) ← ((RLi) + disp8)	—	*	—	—	—	*	*	—	—	—
MOVW A, @SP + disp8	3	3	(c)	word (A) ← ((SP) + disp8)	—	*	—	—	—	*	*	—	—	—
MOVW A, addr24	5	3	(c)	word (A) ← (addr24)	—	*	—	—	—	*	*	—	—	—
MOVW A, @A	2	2	(c)	word (A) ← ((A))	—	—	—	—	—	*	*	—	—	—
MOVW dir, A	2	2	(c)	word (dir) ← (A)	—	—	—	—	—	*	*	—	—	—
MOVW addr16, A	3	2	(c)	word (addr16) ← (A)	—	—	—	—	—	*	*	—	—	—
MOVW SP, #imm16	4	2	0	word (SP) ← imm16	—	—	—	—	—	*	*	—	—	—
MOVW SP, A	1	2	0	word (SP) ← (A)	—	—	—	—	—	*	*	—	—	—
MOVW RWi, A	1	1	0	word (RWi) ← (A)	—	—	—	—	—	*	*	—	—	—
MOVW ear, A	2	2	0	word (ear) ← (A)	—	—	—	—	—	*	*	—	—	—
MOVW eam, A	2 +	2 + (a)	(c)	word (eam) ← (A)	—	—	—	—	—	*	*	—	—	—
MOVW io, A	2	2	(c)	word (io) ← (A)	—	—	—	—	—	*	*	—	—	—
MOVW @RWi + disp8, A	2	3	(c)	word ((RWi) + disp8) ← (A)	—	—	—	—	—	*	*	—	—	—
MOVW @RLi + disp8, A	3	6	(c)	word ((RLi) + disp8) ← (A)	—	—	—	—	—	*	*	—	—	—
MOVW @SP + disp8, A	3	3	(c)	word ((SP) + disp8) ← (A)	—	—	—	—	—	*	*	—	—	—
MOVW addr24, A	5	3	(c)	word (addr24) ← (A)	—	—	—	—	—	*	*	—	—	—
MOVW @A, RWi	2	3	(c)	word ((A)) ← (RWi)	—	—	—	—	—	*	*	—	—	—
MOVW RWi, ear	2	2	0	word (RWi) ← (ear)	—	—	—	—	—	*	*	—	—	—
MOVW RWi, eam	2 +	3 + (a)	(c)	word (RWi) ← (eam)	—	—	—	—	—	*	*	—	—	—
MOVW ear, RWi	2	3	0	word (ear) ← (RWi)	—	—	—	—	—	*	*	—	—	—
MOVW eam, RWi	2 +	3 + (a)	(c)	word (eam) ← (RWi)	—	—	—	—	—	*	*	—	—	—
MOVW RWi, #imm16	3	2	0	word (RWi) ← imm16	—	—	—	—	—	*	*	—	—	—
MOVW io, #imm16	4	3	(c)	word (io) ← imm16	—	—	—	—	—	—	—	—	—	—
MOVW ear, #imm16	4	2	0	word (ear) ← imm16	—	—	—	—	—	*	*	—	—	—
MOVW eam, #imm16	4 +	2 + (a)	(c)	word (eam) ← imm16	—	—	—	—	—	—	—	—	—	—
MOVW @AL, AH	2	2	(c)	word ((A)) ← (AH)	—	—	—	—	—	*	*	—	—	—
XCHW A, ear	2	3	0	word (A) ↔ (ear)	—	—	—	—	—	—	—	—	—	—
XCHW A, eam	2 +	3 + (a)	2 × (c)	word (A) ↔ (eam)	—	—	—	—	—	—	—	—	—	—
XCHW RWi, ear	2	4	0	word (RWi) ↔ (ear)	—	—	—	—	—	—	—	—	—	—
XCHW RWi, eam	2 +	5 + (a)	2 × (c)	word (RWi) ↔ (eam)	—	—	—	—	—	—	—	—	—	—

Note: For (a) and (c), refer to “Table 4 Number of Execution Cycles in Addressing Modes” and “Table 5 Correction Values for Number of Cycles for Calculating Actual Number of Cycles.”

MB90210 Series

Table 8 Transmission Instruction (Long) [11 Instructions]

Mnemonic	#	~	B	Operation	LH	AH	I	S	T	N	Z	V	C	RMW
MOVL A, ear	2	2	0	long (A) ← (ear)	–	–	–	–	–	*	*	–	–	–
MOVL A, eam	2 +	3 + (a)	(d)	long (A) ← (eam)	–	–	–	–	–	*	*	–	–	–
MOVL A, #imm32	5	3	0	long (A) ← imm32	–	–	–	–	–	*	*	–	–	–
MOVL A, @SP + disp8	3	4	(d)	long (A) ← ((SP) + disp8)	–	–	–	–	–	*	*	–	–	–
MOVPL A, addr24	5	4	(d)	long (A) ← (addr24)	–	–	–	–	–	*	*	–	–	–
MOVPL A, @A	2	3	(d)	long (A) ← ((A))	–	–	–	–	–	*	*	–	–	–
MOVPL @A, RLi	2	5	(d)	long ((A)) ← (RLi)	–	–	–	–	–	*	*	–	–	–
MOVL @SP + disp8, A	3	4	(d)	long ((SP) + disp8) ← (A)	–	–	–	–	–	*	*	–	–	–
MOVPL addr24, A	5	4	(d)	long (addr24) ← (A)	–	–	–	–	–	*	*	–	–	–
MOVL ear, A	2	2	0	long (ear) ← (A)	–	–	–	–	–	*	*	–	–	–
MOVL eam, A	2 +	3 + (a)	(d)	long (eam) ← (A)	–	–	–	–	–	*	*	–	–	–

Note: For (a) and (c), refer to “Table 4 Number of Execution Cycles in Addressing Modes” and “Table 5 Correction Values for Number of Cycles for Calculating Actual Number of Cycles.”

Table 9 Add/Subtract (Byte, Word, Long) [42 Instructions]

Mnemonic	#	~	B	Operation	LH	AH	I	S	T	N	Z	V	C	RMW
ADD A,#imm8	2	2	0	byte (A) ← (A) +imm8	Z	—	—	—	—	*	*	*	*	—
ADD A, dir	2	3	(b)	byte (A) ← (A) +(dir)	Z	—	—	—	—	*	*	*	*	—
ADD A, ear	2	2	0	byte (A) ← (A) +(ear)	Z	—	—	—	—	*	*	*	*	—
ADD A, eam	2+	3+(a)	(b)	byte (A) ← (A) +(eam)	Z	—	—	—	—	*	*	*	*	—
ADD ear, A	2	2	0	byte (ear) ← (ear) + (A)	—	—	—	—	—	*	*	*	*	*
ADD eam, A	2+	3+(a)	2×(b)	byte (eam) ← (eam) + (A)	Z	—	—	—	—	*	*	*	*	*
ADDC A	1	2	0	byte (A) ← (AH) + (AL) + (C)	Z	—	—	—	—	*	*	*	*	—
ADDC A, ear	2	2	0	byte (A) ← (A) + (ear) + (C)	Z	—	—	—	—	*	*	*	*	—
ADDC A, eam	2+	3+(a)	(b)	byte (A) ← (A) + (eam) + (C)	Z	—	—	—	—	*	*	*	*	—
ADDC A	1	3	0	byte (A) ← (AH) + (AL) + (C) (decimal)	Z	—	—	—	—	*	*	*	*	—
SUB A,#imm8	2	2	0	byte (A) ← (A) – imm8	Z	—	—	—	—	*	*	*	*	—
SUB A, dir	2	3	(b)	byte (A) ← (A) – (dir)	Z	—	—	—	—	*	*	*	*	—
SUB A, ear	2	2	0	byte (A) ← (A) – (ear)	Z	—	—	—	—	*	*	*	*	—
SUB A, eam	2+	3+(a)	(b)	byte (A) ← (A) – (eam)	Z	—	—	—	—	*	*	*	*	—
SUB ear, A	2	2	0	byte (ear) ← (ear) – (A)	—	—	—	—	—	*	*	*	*	*
SUB eam, A	2+	3+(a)	2×(b)	byte (eam) ← (eam) – (A)	—	—	—	—	—	*	*	*	*	*
SUBC A	1	2	0	byte (A) ← (AH) – (AL) – (C)	Z	—	—	—	—	*	*	*	*	—
SUBC A, ear	2	2	0	byte (A) ← (A) – (ear) – (C)	Z	—	—	—	—	*	*	*	*	—
SUBC A, eam	2+	3+(a)	(b)	byte (A) ← (A) – (eam) – (C)	Z	—	—	—	—	*	*	*	*	—
SUBDC A	1	3	0	byte (A) ← (AH) – (AL) – (C) (decimal)	Z	—	—	—	—	*	*	*	*	—
ADDW A	1	2	0	word (A) ← (AH) + (AL)	—	—	—	—	—	*	*	*	*	—
ADDW A, ear	2	2	0	word (A) ← (A) + (ear)	—	—	—	—	—	*	*	*	*	—
ADDW A, eam	2+	3+(a)	(c)	word (A) ← (A) + (eam)	—	—	—	—	—	*	*	*	*	—
ADDW A,#imm16	3	2	0	word (A) ← (A) + imm16	—	—	—	—	—	*	*	*	*	—
ADDW ear, A	2	2	0	word (ear) ← (ear) + (A)	—	—	—	—	—	*	*	*	*	*
ADDW eam, A	2+	3+(a)	2×(c)	word (eam) ← (eam) + (A)	—	—	—	—	—	*	*	*	*	*
ADDCW A, ear	2	2	0	word (A) ← (A) + (ear) + (C)	—	—	—	—	—	*	*	*	*	—
ADDCW A, eam	2+	3+(a)	(c)	word (A) ← (A) + (eam) + (C)	—	—	—	—	—	*	*	*	*	—
SUBW A	1	2	0	word (A) ← (AH) – (AL)	—	—	—	—	—	*	*	*	*	—
SUBW A, ear	2	2	0	word (A) ← (A) – (ear)	—	—	—	—	—	*	*	*	*	—
SUBW A, eam	2+	3+(a)	(c)	word (A) ← (A) – (eam)	—	—	—	—	—	*	*	*	*	—
SUBW A,#imm16	3	2	0	word (A) ← (A) – imm16	—	—	—	—	—	*	*	*	*	—
SUBW ear, A	2	2	0	word (ear) ← (ear) – (A)	—	—	—	—	—	*	*	*	*	*
SUBW eam, A	2+	3+(a)	2×(c)	word (eam) ← (eam) – (A)	—	—	—	—	—	*	*	*	*	*
SUBCW A, ear	2	2	0	word (A) ← (A) – (ear) – (C)	—	—	—	—	—	*	*	*	*	—
SUBCW A, eam	2+	3+(a)	(c)	word (A) ← (A) – (eam) – (C)	—	—	—	—	—	*	*	*	*	—
ADDL A, ear	2	5	0	long (A) ← (A) + (ear)	—	—	—	—	—	*	*	*	*	—
ADDL A, eam	2+	6+(a)	(d)	long (A) ← (A) + (eam)	—	—	—	—	—	*	*	*	*	—
ADDL A,#imm32	5	4	0	long (A) ← (A) + imm32	—	—	—	—	—	*	*	*	*	—
SUBL A, ear	2	5	0	long (A) ← (A) – (ear)	—	—	—	—	—	*	*	*	*	—
SUBL A, eam	2+	6+(a)	(d)	long (A) ← (A) – (eam)	—	—	—	—	—	*	*	*	*	—
SUBL A,#imm32	5	4	0	long (A) ← (A) – imm32	—	—	—	—	—	*	*	*	*	—

Note: For (a) to (d), refer to “Table 4 Number of Execution Cycles in Addressing Modes” and “Table 5 Correction Values for Number of Cycles for Calculating Actual Number of Cycles.”

MB90210 Series

Table 10 Increment/Decrement (Byte, Word, Long) [12 Instructions]

Mnemonic		#	~	B	Operation	LH	AH	I	S	T	N	Z	V	C	RMW
INC	ear	2	2	0	byte (ear) ← (ear) +1	-	-	-	-	-	*	*	*	-	*
INC	eam	2 +	3 + (a)	2 × (b)	byte (eam) ← (eam) +1	-	-	-	-	-	*	*	*	-	*
DEC	ear	2	2	0	byte (ear) ← (ear) -1	-	-	-	-	-	*	*	*	-	*
DEC	eam	2 +	3 + (a)	2 × (b)	byte (eam) ← (eam) -1	-	-	-	-	-	*	*	*	-	*
INCW	ear	2	2	0	word (ear) ← (ear) +1	-	-	-	-	-	*	*	*	-	*
INCW	eam	2 +	3 + (a)	2 × (c)	word (eam) ← (eam) +1	-	-	-	-	-	*	*	*	-	*
DECW	ear	2	2	0	word (ear) ← (ear) -1	-	-	-	-	-	*	*	*	-	*
DECW	eam	2 +	3 + (a)	2 × (c)	word (eam) ← (eam) -1	-	-	-	-	-	*	*	*	-	*
INCL	ear	2	4	0	long (ear) ← (ear) +1	-	-	-	-	-	*	*	*	-	-
INCL	eam	2 +	5 + (a)	2 × (d)	long (eam) ← (eam) +1	-	-	-	-	-	*	*	*	-	*
DECL	ear	2	4	0	long (ear) ← (ear) -1	-	-	-	-	-	*	*	*	-	*
DECL	eam	2 +	5 + (a)	2 × (d)	long (eam) ← (eam) -1	-	-	-	-	-	*	*	*	-	*

Note: For (a) to (d), refer to “Table 4 Number of Execution Cycles in Addressing Modes” and “Table 5 Correction Values for Number of Cycles for Calculating Actual Number of Cycles.”

Table 11 Compare (Byte, Word, Long) [11 Instructions]

Mnemonic		#	~	B	Operation	LH	AH	I	S	T	N	Z	V	C	RMW
CMP	A	1	1	0	byte (AH) - (AL)	-	-	-	-	-	*	*	*	*	-
CMP	A, ear	2	2	0	byte (A) - (ear)	-	-	-	-	-	*	*	*	*	-
CMP	A, eam	2 +	3 + (a)	(b)	byte (A) - (eam)	-	-	-	-	-	*	*	*	*	-
CMP	A, #imm8	2	2	0	byte (A) - imm8	-	-	-	-	-	*	*	*	*	-
CMPW	A	1	1	0	word (AH) - (AL)	-	-	-	-	-	*	*	*	*	-
CMPW	A, ear	2	2	0	word (A) - (ear)	-	-	-	-	-	*	*	*	*	-
CMPW	A, eam	2 +	3 + (a)	(c)	word (A) - (eam)	-	-	-	-	-	*	*	*	*	-
CMPW	A, #imm16	3	2	0	word (A) - imm16	-	-	-	-	-	*	*	*	*	-
CMPL	A, ear	2	6	0	word (A) - (ear)	-	-	-	-	-	*	*	*	*	-
CMPL	A, eam	2 +	7 + (a)	(d)	word (A) - (eam)	-	-	-	-	-	*	*	*	*	-
CMPL	A, #imm32	5	3	0	word (A) - imm32	-	-	-	-	-	*	*	*	*	-

Note: For (a) to (d), refer to “Table 4 Number of Execution Cycles in Addressing Modes” and “Table 5 Correction Values for Number of Cycles for Calculating Actual Number of Cycles.”

Table 12 Unsigned Multiply/Division (Word, Long) [11 Instructions]

Mnemonic	#	~	B	Operation	LH	AH	I	S	T	N	Z	V	C	RMW
DIVU A	1	*1	0	word (AH) /byte (AL) Quotient → byte (AL) Remainder → byte (AH)	–	–	–	–	–	–	–	*	*	–
DIVU A, ear	2	*2	0	word (A)/byte (ear) Quotient → byte (A) Remainder → byte (ear)	–	–	–	–	–	–	–	*	*	–
DIVU A, eam	2 +	*3	*6	word (A)/byte (eam) Quotient → byte (A) Remainder → byte (eam)	–	–	–	–	–	–	–	*	*	–
DIVUW A, ear	2	*4	0	long (A)/word (ear) Quotient → word (A) Remainder → word (ear)	–	–	–	–	–	–	–	*	*	–
DIVUW A, eam	2 +	*5	*7	long (A)/word (eam) Quotient → word (A) Remainder → word (eam)	–	–	–	–	–	–	–	*	*	–
MULU A	1	*8	0	byte (AH) byte (AL) → word (A)	–	–	–	–	–	–	–	–	–	–
MULU A, ear	2	*9	0	byte (A) byte (ear) → word (A)	–	–	–	–	–	–	–	–	–	–
MULU A, eam	2 +	*10	(b)	byte (A) byte (eam) → word (A)	–	–	–	–	–	–	–	–	–	–
MULUW A	1	*11	0	word (AH) word (AL) → long (A)	–	–	–	–	–	–	–	–	–	–
MULUW A, ear	2	*12	0	word (A) word (ear) → long (A)	–	–	–	–	–	–	–	–	–	–
MULUW A, eam	2 +	*13	(c)	word (A) word (eam) → long (A)	–	–	–	–	–	–	–	–	–	–

Note: For (b) and (c), refer to “Table 5 Correction Values for Number of Cycles for Calculating Actual Number of Cycles.”

- *1: Set to 3 when the division-by-0, 6 for an overflow, and 14 for normal operation.
- *2: Set to 3 when the division-by-0, 6 for an overflow, and 13 for normal operation.
- *3: Set to 5 + (a) when the division-by-0, 7 + (a) for an overflow, and 17 + (a) for normal operation.
- *4: Set to 3 when the division-by-0, 5 for an overflow, and 21 for normal operation.
- *5: Set to 4 + (a) when the division-by-0, 7 + (a) for an overflow, and 25 + (a) for normal operation.
- *6: When the division-by-0, (b) for an overflow, and 2 × (b) for normal operation.
- *7: When the division-by-0, (c) for an overflow, and 2 × (c) for normal operation.
- *8: Set to 3 when byte (AH) is zero, 7 when byte (AH) is not zero.
- *9: Set to 3 when byte (ear) is zero, 7 when byte (ear) is not zero.
- *10: Set to 4 + (a) when byte (eam) is zero, 8 + (a) when byte (eam) is not zero.
- *11: Set to 3 when word (AH) is zero, 11 when word (AH) is not zero.
- *12: Set to 4 when word (ear) is zero, 11 when word (ear) is not zero.
- *13: Set to 4 + (a) when word (eam) is zero, 12 + (a) when word (eam) is not zero.

MB90210 Series

Table 13 Signed multiplication/division (Word, Long) [11 Instructions]

Mnemonic	#	~	B	Operation	LH	AH	I	S	T	N	Z	V	C	RMW
DIV A	2	*1	0	word (AH)/byte (AL) Quotient → byte (AL) Remainder → byte (AH)	Z	–	–	–	–	–	–	*	*	–
DIV A, ear	2	*2	0	word (A)/byte (ear) Quotient → byte (A) Remainder → byte (ear)	Z	–	–	–	–	–	–	*	*	–
DIV A, eam	2 +	*3	*6	word (A)/byte (eam) Quotient → byte (A) Remainder → byte (eam)	Z	–	–	–	–	–	–	*	*	–
DIVW A, ear	2	*4	0	long (A)/word (ear) Quotient → word (A) Remainder → word (ear)	–	–	–	–	–	–	–	*	*	–
DIVW A, eam	2 +	*5	*7	long (A)/word (eam) Quotient → word (A) Remainder → word (eam)	–	–	–	–	–	–	–	*	*	–
MUL A	2	*8	0	byte (AH) × byte (AL) → word (A)	–	–	–	–	–	–	–	–	–	–
MUL A, ear	2	*9	0	byte (A) × byte (ear) → word (A)	–	–	–	–	–	–	–	–	–	–
MUL A, eam	2 +	*10	(b)	byte (A) × byte (eam) → word (A)	–	–	–	–	–	–	–	–	–	–
MULW A	2	*11	0	word (AH) × word (AL) → long (A)	–	–	–	–	–	–	–	–	–	–
MULW A, ear	2	*12	0	word (A) × word (ear) → long (A)	–	–	–	–	–	–	–	–	–	–
MULW A, eam	2 +	*13	(b)	word (A) × word (eam) → long (A)	–	–	–	–	–	–	–	–	–	–

For (b) and (c), refer to “Table 5 Correction Values for Number of Cycles for Calculating Actual Number of Cycles.”

- *1: Set to 3 for divide-by-0, 8 or 18 for an overflow, and 18 for normal operation.
- *2: Set to 3 for divide-by-0, 10 or 21 for an overflow, and 22 for normal operation.
- *3: Set to 4 + (a) for divide-by-0, 11 + (a) or 22 + (a) for an overflow, and 23 + (a) for normal operation.
- *4: Positive divided: Set to 4 for divide-by-0, 10 or 29 for an overflow, and 30 for normal operation.
Negative divided: Set to 4 for divide-by-0, 11 or 30 for an overflow, and 31 for normal operation.
- *5: Positive divided: Set to 4 + (a) for divide-by-0, 11 + (a) or 30 + (a) for an overflow, and 31 + (a) for normal operation.
Negative divided: Set to 4 + (a) for divide-by-0, 12 + (a) or 31 + (a) for an overflow, and 32 + (a) for normal operation.
- *6: Set to (b) when the division-by-0 or an overflow, and 2 × (b) for normal operation.
- *7: Set to (c) when the division-by-0 or an overflow, and 2 × (c) for normal operation.
- *8: Set to 3 when byte (AH) is zero, 12 when the result is positive, and 13 when the result is negative.
- *9: Set to 3 when byte (ear) is zero, 12 when the result is positive, and 13 when the result is negative.
- *10: Set to 4 + (a) when byte (eam) is zero, 13 + (a) when the result is positive, and 14 + (a) when the result is negative.
- *11: Set to 3 when word (AH) is zero, 12 when the result is positive, and 13 when the result is negative.
- *12: Set to 3 when word (ear) is zero, 16 when the result is positive, and 19 when the result is negative.
- *13: Set to 4 + (a) when word (eam) is zero, 17 + (a) when the result is positive, and 20 + (a) when the result is negative.

Note: When overflow occurs during DIV or DIVW instruction execution, the number of execution cycles takes two values because of detection before and after an operation.
When overflow occurs during DIV or DIVW instruction execution, the contents of AL are destroyed.

Table 14 Logic 1 (Byte, Word) [39 Instructions]

Mnemonic	#	~	B	Operation	LH	AH	I	S	T	N	Z	V	C	RMW
AND A, #imm8	2	2	0	byte (A) ← (A) and imm8	–	–	–	–	–	*	*	R	–	–
AND A, ear	2	2	0	byte (A) ← (A) and (ear)	–	–	–	–	–	*	*	R	–	–
AND A, eam	2 +	3 + (a)	(b)	byte (A) ← (A) and (eam)	–	–	–	–	–	*	*	R	–	–
AND ear, A	2	3	0	byte (ear) ← (ear) and (A)	–	–	–	–	–	*	*	R	–	*
AND eam, A	2 +	3 + (a)	2 × (b)	byte (eam) ← (eam) and (A)	–	–	–	–	–	*	*	R	–	*
OR A, #imm8	2	2	0	byte (A) ← (A) or imm8	–	–	–	–	–	*	*	R	–	–
OR A, ear	2	2	0	byte (A) ← (A) or (ear)	–	–	–	–	–	*	*	R	–	–
OR A, eam	2 +	3 + (a)	(b)	byte (A) ← (A) or (eam)	–	–	–	–	–	*	*	R	–	–
OR ear, A	2	3	0	byte (ear) ← (ear) or (A)	–	–	–	–	–	*	*	R	–	*
OR eam, A	2 +	3 + (a)	2 × (b)	byte (eam) ← (eam) or (A)	–	–	–	–	–	*	*	R	–	*
XOR A, #imm8	2	2	0	byte (A) ← (A) xor imm8	–	–	–	–	–	*	*	R	–	–
XOR A, ear	2	2	0	byte (A) ← (A) xor (ear)	–	–	–	–	–	*	*	R	–	–
XOR A, eam	2 +	3 + (a)	(b)	byte (A) ← (A) xor (eam)	–	–	–	–	–	*	*	R	–	–
XOR ear, A	2	3	0	byte (ear) ← (ear) xor (A)	–	–	–	–	–	*	*	R	–	*
XOR eam, A	2 +	3 + (a)	2 × (b)	byte (eam) ← (eam) xor (A)	–	–	–	–	–	*	*	R	–	*
NOT A	1	2	0	byte (A) ← not (A)	–	–	–	–	–	*	*	R	–	–
NOT ear	2	2	0	byte (ear) ← not (ear)	–	–	–	–	–	*	*	R	–	*
NOT eam	2 +	3 + (a)	2 × (b)	byte (eam) ← not (eam)	–	–	–	–	–	*	*	R	–	*
ANDW A	1	2	0	word (A) ← (AH) and (A)	–	–	–	–	–	*	*	R	–	–
ANDW A, #imm16	3	2	0	word (A) ← (A) and imm16	–	–	–	–	–	*	*	R	–	–
ANDW A, ear	2	2	0	word (A) ← (A) and (ear)	–	–	–	–	–	*	*	R	–	–
ANDW A, eam	2 +	3 + (a)	(c)	word (A) ← (A) and (eam)	–	–	–	–	–	*	*	R	–	–
ANDW ear, A	2	3	0	word (ear) ← (ear) and (A)	–	–	–	–	–	*	*	R	–	*
ANDW eam, A	2 +	3 + (a)	2 × (c)	word (eam) ← (eam) and (A)	–	–	–	–	–	*	*	R	–	*
ORW A	1	2	0	word (A) ← (AH) or (A)	–	–	–	–	–	*	*	R	–	–
ORW A, #imm16	3	2	0	word (A) ← (A) or imm16	–	–	–	–	–	*	*	R	–	–
ORW A, ear	2	2	0	word (A) ← (A) or (ear)	–	–	–	–	–	*	*	R	–	–
ORW A, eam	2 +	3 + (a)	(c)	word (A) ← (A) or (eam)	–	–	–	–	–	*	*	R	–	–
ORW ear, A	2	3	0	word (ear) ← (ear) or (A)	–	–	–	–	–	*	*	R	–	*
ORW eam, A	2 +	3 + (a)	2 × (c)	word (eam) ← (eam) or (A)	–	–	–	–	–	*	*	R	–	*
XORW A	1	2	0	word (A) ← (AH) xor (A)	–	–	–	–	–	*	*	R	–	–
XORW A, #imm16	3	2	0	word (A) ← (A) xor imm16	–	–	–	–	–	*	*	R	–	–
XORW A, ear	2	2	0	word (A) ← (A) xor (ear)	–	–	–	–	–	*	*	R	–	–
XORW A, eam	2 +	3 + (a)	(c)	word (A) ← (A) xor (eam)	–	–	–	–	–	*	*	R	–	–
XORW ear, A	2	3	0	word (ear) ← (ear) xor (A)	–	–	–	–	–	*	*	R	–	*
XORW eam, A	2 +	3 + (a)	2 × (c)	word (eam) ← (eam) xor (A)	–	–	–	–	–	*	*	R	–	*
NOTW A	1	2	0	word (A) ← not (A)	–	–	–	–	–	*	*	R	–	–
NOTW ear	2	3	0	word (ear) ← not (ear)	–	–	–	–	–	*	*	R	–	*
NOTW eam	2 +	3 + (a)	2 × (c)	word (eam) ← not (eam)	–	–	–	–	–	*	*	R	–	*

Note: For (a) to (c), refer to “Table 4 Number of Execution Cycles in Addressing Modes” and “Table 5 Correction Values for Number of Cycles for Calculating Actual Number of Cycles.”

MB90210 Series

Table 15 Logic 2 (Long) [6 Instructions]

Mnemonic	#	~	B	Operation	LH	AH	I	S	T	N	Z	V	C	RMW
ANDL A, ear	2	5	0	long (A) ← (A) and (ear)	-	-	-	-	-	*	*	R	-	-
ANDL A, eam	2 +	6 + (a)	(d)	long (A) ← (A) and (eam)	-	-	-	-	-	*	*	R	-	-
ORL A, ear	2	5	0	long (A) ← (A) or (ear)	-	-	-	-	-	*	*	R	-	-
ORL A, eam	2 +	6 + (a)	(d)	long (A) ← (A) or (eam)	-	-	-	-	-	*	*	R	-	-
XORL A, ear	2	5	0	long (A) ← (A) xor (ear)	-	-	-	-	-	*	*	R	-	-
XORL A, eam	2 +	6 + (a)	(d)	long (A) ← (A) xor (eam)	-	-	-	-	-	*	*	R	-	-

Note: For (a) and (d), refer to “Table 4 Number of Execution Cycles in Addressing Modes” and “Table 5 Correction Values for Number of Cycles for Calculating Actual Number of Cycles.”

Table 16 Sign Reverse (Byte, Word) [6 Instructions]

Mnemonic	#	~	RG	B	Operation	LH	AH	I	S	T	N	Z	V	C	RMW
NEG A	1	2	0	0	byte (A) ← 0 – (A)	X	-	-	-	-	*	*	*	*	-
NEG ear	2	3	2	0	byte (ear) ← 0 – (ear)	-	-	-	-	-	*	*	*	*	-
NEG eam	2 +	5 + (a)	0	2 × (b)	byte (eam) ← 0 – (eam)	-	-	-	-	-	*	*	*	*	*
NEGW A	1	2	0	0	word (A) ← 0 – (A)	-	-	-	-	-	*	*	*	*	-
NEGW ear	2	3	2	0	word (ear) ← 0 – (ear)	-	-	-	-	-	*	*	*	*	-
NEGW eam	2 +	5 + (a)	0	2 × (c)	word (eam) ← 0 – (eam)	-	-	-	-	-	*	*	*	*	*

Note: For (a) and (d), refer to “Table 4 Number of Execution Cycles in Addressing Modes” and “Table 5 Correction Values for Number of Cycles for Calculating Actual Number of Cycles.”

Table 17 Absolute Values (Byte, Word, Long) [3 Instructions]

Mnemonic	#	~	B	Operation	LH	AH	I	S	T	N	Z	V	C	RMW
ABS A	2	2	0	byte (A) ← Absolute value (A)	Z	-	-	-	-	*	*	*	-	-
ABSW A	2	2	0	word (A) ← Absolute value (A)	-	-	-	-	-	*	*	*	-	-
ABSL A	2	4	0	long (A) ← Absolute value (A)	-	-	-	-	-	*	*	*	-	-

Table 18 Normalize Instruction (Long) [1 Instruction]

Mnemonic	#	~	RG	B	Operation	LH	AH	I	S	T	N	Z	V	C	RMW
NRML A, R0	2	*1	1	0	long (A) ← Shift to where “1” is originally located byte (R0) ← Number of shifts in the operation	-	-	-	-	-	-	*	-	-	-

* : Set to 5 when the accumulator is all “0”, otherwise set to 5 + (R0).

Table 19 Shift Type Instruction (Byte, Word, Long) [27 Instructions]

Mnemonic	#	~	B	Operation	LH	AH	I	S	T	N	Z	V	C	RMW
RORC A	2	2	0	byte (A) ← With right-rotate carry	-	-	-	-	-	*	*	-	*	-
ROLC A	2	2	0	byte (A) ← With left-rotate carry	-	-	-	-	-	*	*	-	*	-
RORC ear	2	2	0	byte (ear) ← With right-rotate carry	-	-	-	-	-	*	*	-	*	*
RORC eam	2 +	3 + (a)	2 × (b)	byte (eam) ← With right-rotate carry	-	-	-	-	-	*	*	-	*	*
ROLC ear	2	2	0	byte (ear) ← With left-rotate carry	-	-	-	-	-	*	*	-	*	*
ROLC eam	2 +	3 + (a)	2 × (b)	byte (eam) ← With left-rotate carry	-	-	-	-	-	*	*	-	*	*
ASR A, R0	2	*1	0	byte (A) ← Arithmetic right barrel shift (A, R0)	-	-	-	-	*	*	*	-	*	-
LSR A, R0	2	*1	0	byte (A) ← Logical right barrel shift (A, R0)	-	-	-	-	*	*	*	-	*	-
LSL A, R0	2	*1	0	byte (A) ← Logical left barrel shift (A, R0)	-	-	-	-	-	*	*	-	*	-
ASR A, #imm8	3	*3	0	byte (A) ← Arithmetic right barrel shift (A, imm8)	-	-	-	-	*	*	*	-	*	-
LSR A, #imm8	3	*3	0	byte (A) ← Logical right barrel shift (A, imm8)	-	-	-	-	*	*	*	-	*	-
LSL A, #imm8	3	*3	0	byte (A) ← Logical left barrel shift (A, imm8)	-	-	-	-	-	*	*	-	*	-
ASRW A	1	2	0	word (A) ← Arithmetic right shift (A, 1 bit)	-	-	-	-	*	*	*	-	*	-
LSRW A/SHRW A	1	2	0	word (A) ← Logical right shift (A, 1 bit)	-	-	-	-	*	R	*	-	*	-
LSLW A/SHLW A	1	2	0	word (A) ← Logical left shift (A, 1 bit)	-	-	-	-	-	*	*	-	*	-
ASRW A, R0	2	*1	0	word (A) ← Arithmetic right barrel shift (A, R0)	-	-	-	-	*	*	*	-	*	-
LSRW A, R0	2	*1	0	word (A) ← Logical right barrel shift (A, R0)	-	-	-	-	*	*	*	-	*	-
LSLW A, R0	2	*1	0	word (A) ← Logical left barrel shift (A, R0)	-	-	-	-	-	*	*	-	*	-
ASRW A, #imm8	3	*3	0	word (A) ← Arithmetic right barrel shift (A, imm8)	-	-	-	-	*	*	*	-	*	-
LSRW A, #imm8	3	*3	0	word (A) ← Logical right barrel shift (A, imm8)	-	-	-	-	*	*	*	-	*	-
LSLW A, #imm8	3	*3	0	word (A) ← Logical left barrel shift (A, imm8)	-	-	-	-	-	*	*	-	*	-
ASRL A, R0	2	*2	0	long (A) ← Arithmetic right barrel shift (A, R0)	-	-	-	-	*	*	*	-	*	-
LSRL A, R0	2	*2	0	long (A) ← Logical right barrel shift (A, R0)	-	-	-	-	*	*	*	-	*	-
LSLL A, R0	2	*2	0	long (A) ← Logical left barrel shift (A, R0)	-	-	-	-	-	*	*	-	*	-
ASRL A, #imm8	3	*4	0	long (A) ← Arithmetic right barrel shift (A, imm8)	-	-	-	-	*	*	*	-	*	-
LSRL A, #imm8	3	*4	0	long (A) ← Logical right barrel shift (A, imm8)	-	-	-	-	*	*	*	-	*	-
LSLL A, #imm8	3	*4	0	long (A) ← Logical left barrel shift (A, imm8)	-	-	-	-	-	*	*	-	*	-

Note: For (a) and (b), refer to “Table 4 Number of Execution Cycles in Addressing Modes” and “Table 5 Correction Values for Number of Cycles for Calculating Actual Number of Cycles.”

- *1: Set to 3 when R0 is 0, otherwise 3 + (R0).
- *2: Set to 3 when R0 is 0, otherwise 4 + (R0).
- *3: Set to 3 when imm8 is 0, otherwise 3 + imm8.
- *4: Set to 3 when imm8 is 0, otherwise 4 + imm8.

MB90210 Series

Table 20 Branch 1 [31 Instructions]

Mnemonic	#	~	B	Operation	LH	AH	I	S	T	N	Z	V	C	RMW
BZ/BEQ rel	2	*1	0	Branch if (Z) = 1	-	-	-	-	-	-	-	-	-	-
BNZ/BNE rel	2	*1	0	Branch if (Z) = 0	-	-	-	-	-	-	-	-	-	-
BC/BLO rel	2	*1	0	Branch if (C) = 1	-	-	-	-	-	-	-	-	-	-
BNC/BHS rel	2	*1	0	Branch if (C) = 0	-	-	-	-	-	-	-	-	-	-
BN rel	2	*1	0	Branch if (N) = 1	-	-	-	-	-	-	-	-	-	-
BP rel	2	*1	0	Branch if (N) = 0	-	-	-	-	-	-	-	-	-	-
BV rel	2	*1	0	Branch if (V) = 1	-	-	-	-	-	-	-	-	-	-
BNV rel	2	*1	0	Branch if (V) = 0	-	-	-	-	-	-	-	-	-	-
BT rel	2	*1	0	Branch if (T) = 1	-	-	-	-	-	-	-	-	-	-
BNT rel	2	*1	0	Branch if (T) = 0	-	-	-	-	-	-	-	-	-	-
BLT rel	2	*1	0	Branch if (V) xor (N) = 1	-	-	-	-	-	-	-	-	-	-
BGE rel	2	*1	0	Branch if (V) xor (N) = 0	-	-	-	-	-	-	-	-	-	-
BLE rel	2	*1	0	Branch if ((V) xor (N)) or (Z) = 1	-	-	-	-	-	-	-	-	-	-
BGT rel	2	*1	0	Branch if ((V) xor (N)) or (Z) = 0	-	-	-	-	-	-	-	-	-	-
BLS rel	2	*1	0	Branch if (C) or (Z) = 1	-	-	-	-	-	-	-	-	-	-
BHI rel	2	*1	0	Branch if (C) or (Z) = 0	-	-	-	-	-	-	-	-	-	-
BRA rel	2	*1	0	Branch unconditionally	-	-	-	-	-	-	-	-	-	-
JMP @A	1	2	0	word (PC) ← (A)	-	-	-	-	-	-	-	-	-	-
JMP addr16	3	2	0	word (PC) ← addr16	-	-	-	-	-	-	-	-	-	-
JMP @ear	2	3	0	word (PC) ← (ear)	-	-	-	-	-	-	-	-	-	-
JMP @eam	2 +	4 + (a)	(c)	word (PC) ← (eam)	-	-	-	-	-	-	-	-	-	-
JMPP @ear *3	2	3	0	word (PC) ← (ear), (PCB) ← (ear + 2)	-	-	-	-	-	-	-	-	-	-
JMPP @eam *3	2 +	4 + (a)	(d)	word (PC) ← (eam), (PCB) ← (eam + 2)	-	-	-	-	-	-	-	-	-	-
JMPP addr24	4	3	0	word (PC) ← ad24 0 – 15, (PCB) ← ad24 16 – 23	-	-	-	-	-	-	-	-	-	-
CALL @ear *4	2	4	(c)	word (PC) ← (ear)	-	-	-	-	-	-	-	-	-	-
CALL @eam *4	2 +	5 + (a)	2 × (c)	word (PC) ← (eam)	-	-	-	-	-	-	-	-	-	-
CALL addr16 *5	3	5	(c)	word (PC) ← addr16	-	-	-	-	-	-	-	-	-	-
CALLV #vct4 *5	1	5	2 × (c)	Vector call instruction	-	-	-	-	-	-	-	-	-	-
CALLP @ear *6	2	7	2 × (c)	word (PC) ← (ear) 0 – 15 (PCB) ← (ear) 16 – 23	-	-	-	-	-	-	-	-	-	-
CALLP @eam *6	2 +	8 + (a)	*2	word (PC) ← (eam) 0 – 15 (PCB) ← (eam) 16 – 23	-	-	-	-	-	-	-	-	-	-
CALLP addr24 *7	4	7	2 × (c)	word (PC) ← addr0 – 15, (PCB) ← addr16 – 23	-	-	-	-	-	-	-	-	-	-

Note: For (a), (c) and (d), refer to “Table 4 Number of Execution Cycles in Addressing Modes” and “Table 5 Correction Values for Number of Cycles for Calculating Actual Number of Cycles.”

*1: Set to 3 when branch is executed, and 2 when branch is not executed.

*2: $3 \times (c) + (b)$

*3: Reads (word) of the branch destination address.

*4: W pushes to stack (word), and R reads (word) of the branch destination address.

*5: Pushes to stack (word).

*6: W pushes to stack (long), and R reads (long) of the branch destination address.

*7: Pushes to stack (long).

Table 21 Branch 2 [20 Instructions]

Mnemonic	#	~	B	Operation	LH	AH	I	S	T	N	Z	V	C	RMW
CBNE A, #imm8, rel	3	*1	0	Branch if byte (A) ≠ imm8	—	—	—	—	—	*	*	*	*	—
CWBNE A, #imm16, rel	4	*1	0	Branch if word (A) ≠ imm16	—	—	—	—	—	*	*	*	*	—
CBNE ear, #imm8, rel	4	*1	0	Branch if byte (ear) ≠ imm8	—	—	—	—	—	*	*	*	*	—
CBNE eam, #imm8, rel	4+	*3	(b)	Branch if byte (eam) ≠ imm8	—	—	—	—	—	*	*	*	*	—
CWBNE ear, #imm16, rel	5	*1	0	Branch if word (ear) ≠ imm16	—	—	—	—	—	*	*	*	*	—
CWBNE eam, #imm16, rel	5+	*3	(c)	Branch if word (eam) ≠ imm16	—	—	—	—	—	*	*	*	*	—
DBNZ ear, rel	3	*2	0	byte (ear) = (ear) – 1, Branch if (ear) ≠ 0	—	—	—	—	—	*	*	*	—	—
DBNZ eam, rel	3+	*4	2 × (b)	byte (eam) = (eam) – 1, Branch if (eam) ≠ 0	—	—	—	—	—	*	*	*	—	*
DWBNZ ear, rel	3	*2	0	word (ear) = (ear) – 1, Branch if (ear) ≠ 0	—	—	—	—	—	*	*	*	—	—
DWBNZ eam, rel	3+	*4	2 × (c)	word (eam) = (eam) – 1, Branch if (eam) ≠ 0	—	—	—	—	—	*	*	*	—	*
INT #vct8	2	14	8 × (c)	Software interrupt	—	—	R	S	—	—	—	—	—	—
INT addr16	3	12	6 × (c)	Software interrupt	—	—	R	S	—	—	—	—	—	—
INTP addr24	4	13	6 × (c)	Software interrupt	—	—	R	S	—	—	—	—	—	—
INT9	1	14	8 × (c)	Software interrupt	—	—	R	S	—	—	—	—	—	—
RETI	1	9	6 × (c)	Return from interrupt	—	—	*	*	*	*	*	*	*	—
RETIQ *6	2	11	*5	Return from interrupt	—	—	*	*	*	*	*	*	*	—
LINK #imm8	2	6	(c)	Stores old frame pointer in the beginning of the function, set new frame pointer, and reserves local pointer area	—	—	—	—	—	—	—	—	—	—
UNLINK	1	5	(c)	Restore old frame pointer from stack in the end of the function	—	—	—	—	—	—	—	—	—	—
RET *7	1	4	(c)	Return from subroutine	—	—	—	—	—	—	—	—	—	—
RETP *8	1	5	(d)	Return from subroutine	—	—	—	—	—	—	—	—	—	—

Note: For (a) to (d), refer to “Table 4 Number of Execution Cycles in Addressing Modes” and “Table 5 Correction Values for Number of Cycles for Calculating Actual Number of Cycles.”

*1: Set to 4 when branch is executed, and 3 when branch is not executed.

*2: Set to 5 when branch is executed, and 4 when branch is not executed.

*3: Set to 5 + (a) when branch is executed, and 4 + (a) when branch is not executed.

*4: Set to 6 + (a) when branch is executed, and 5 + (a) when branch is not executed.

*5: Set to 3 × (b) + 2 × (c) when an interrupt request is issued, and 6 × (c) for return.

*6: This is a high-speed interrupt return instruction. In the instruction, an interrupt request is detected. When an interrupt occurs, stack operation is not performed, with this instruction branching to the interrupt vector.

*7: Return from stack (word).

*8: Return from stack (long).

MB90210 Series

Table 22 Miscellaneous Control Types (Byte, Word, Long) [36 Instructions]

Mnemonic	#	~	B	Operation	LH	AH	I	S	T	N	Z	V	C	RMW
PUSHW A	1	3	(c)	word (SP) ← (SP) - 2, ((SP)) ← (A)	-	-	-	-	-	-	-	-	-	-
PUSHW AH	1	3	(c)	word (SP) ← (SP) - 2, ((SP)) ← (AH)	-	-	-	-	-	-	-	-	-	-
PUSHW PS	1	3	(c)	word (SP) ← (SP) - 2, ((SP)) ← (PS)	-	-	-	-	-	-	-	-	-	-
PUSHW rlst	2	*3	*4	(PS) ← (PS) - 2n, ((SP)) ← (rlst)	-	-	-	-	-	-	-	-	-	-
POPW A	1	3	(c)	word (A) ← ((SP)), (SP) ← (SP) + 2	-	*	-	-	-	-	-	-	-	-
POPW AH	1	3	(c)	word (AH) ← ((SP)), (SP) ← (SP) + 2	-	-	-	-	-	-	-	-	-	-
POPW PS	1	3	(c)	word (PS) ← ((SP)), (SP) ← (SP) + 2	-	-	*	*	*	*	*	*	*	-
POPW rlst	2	*2	*4	(rlst) ← ((SP)), (SP) ← (SP) + 2n	-	-	-	-	-	-	-	-	-	-
JCTX @A	1	9	6 × (c)	Context switch instruction	-	-	*	*	*	*	*	*	*	-
AND CCR, #imm8	2	3	0	byte (CCR) ← (CCR) and imm8	-	-	*	*	*	*	*	*	*	-
OR CCR, #imm8	2	3	0	byte (CCR) ← (CCR) or imm8	-	-	*	*	*	*	*	*	*	-
MOV RP, #imm8	2	2	0	byte (RP) ← imm8	-	-	-	-	-	-	-	-	-	-
MOV ILM, #imm8	2	2	0	byte (ILM) ← imm8	-	-	-	-	-	-	-	-	-	-
MOVEA RWi, ear	2	3	0	word (RWi) ← ear	-	-	-	-	-	-	-	-	-	-
MOVEA RWi, eam	2 +	2 + (a)	0	word (RWi) ← eam	-	-	-	-	-	-	-	-	-	-
MOVEA A, ear	2	2	0	word (A) ← ear	-	*	-	-	-	-	-	-	-	-
MOVEA A, eam	2 +	1 + (a)	0	word (A) ← eam	-	*	-	-	-	-	-	-	-	-
ADDSP #imm8	2	3	0	word (SP) ← (SP) + ext (imm8)	-	-	-	-	-	-	-	-	-	-
ADDSP #imm16	3	3	0	word (SP) ← (SP) + imm16	-	-	-	-	-	-	-	-	-	-
MOV A, brgl	2	*1	0	byte (A) ← (brgl)	Z	*	-	-	-	*	*	-	-	-
MOV brg2, A	2	1	0	byte (brg2) ← (A)	-	-	-	-	-	*	*	-	-	-
MOV brg2, #imm8	3	2	0	byte (brg2) ← imm8	-	-	-	-	-	*	*	-	-	-
NOP	1	1	0	No operation	-	-	-	-	-	-	-	-	-	-
ADB	1	1	0	Prefix code for accessing AD space	-	-	-	-	-	-	-	-	-	-
DTB	1	1	0	Prefix code for accessing DT space	-	-	-	-	-	-	-	-	-	-
PCB	1	1	0	Prefix code for accessing PC space	-	-	-	-	-	-	-	-	-	-
SPB	1	1	0	Prefix code for accessing SP space	-	-	-	-	-	-	-	-	-	-
NCC	1	1	0	Prefix code for no change in flag	-	-	-	-	-	-	-	-	-	-
CMR	1	1	0	Prefix for common register bank	-	-	-	-	-	-	-	-	-	-
MOVW SPCU, #imm16	4	2	0	word (SPCU) ← (imm16)	-	-	-	-	-	-	-	-	-	-
MOVW SPCL, #imm16	4	2	0	word (SPCL) ← (imm16)	-	-	-	-	-	-	-	-	-	-
SETSPC	2	2	0	Enables stack check operation.	-	-	-	-	-	-	-	-	-	-
CLRSPC	2	2	0	Disables stack check operation.	-	-	-	-	-	-	-	-	-	-
BTSCN A	2	*5	0	Bit position of 1 in byte (A) from word (A)	Z	-	-	-	-	-	*	-	-	-
BTSCNS A	2	*6	0	Bit position (× 2) of 1 in byte (A) from word (A)	Z	-	-	-	-	-	*	-	-	-
BTSCND A	2	*7	0	Bit position (× 4) of 1 in byte (A) from word (A)	Z	-	-	-	-	-	*	-	-	-

Note: For (a) and (c), refer to “Table 4 Number of Execution Cycles in Addressing Modes” and “Table 5 Correction Values for Number of Cycles for Calculating Actual Number of Cycles.”

- *1: PCB, ADB, SSB, USB, and SPB : 1 state
 DTB : 2 states
 DPR : 3 states
- *2: 3 + 4 × (number of POPs)
- *3: 3 + 4 × (number of PUSHes)
- *4: (Number of POPs) × (c), or (number of PUSHes) × (c)
- *5: Set to 3 when AL is 0, 5 when AL is not 0.
- *6: Set to 4 when AL is 0, 6 when AL is not 0.
- *7: Set to 5 when AL is 0, 7 when AL is not 0.

Table 23 Bit Manipulation Instruction [21 Instructions]

Mnemonic	#	~	B	Operation	LH	AH	I	S	T	N	Z	V	C	RMW
MOVB A, dir:bp	3	3	(b)	byte (A) ← (dir:bp) b	Z	*	—	—	—	*	*	—	—	—
MOVB A, addr16:bp	4	3	(b)	byte (A) ← (addr16:bp) b	Z	*	—	—	—	*	*	—	—	—
MOVB A, io:bp	3	3	(b)	byte (A) ← (io:bp) b	Z	*	—	—	—	*	*	—	—	—
MOVB dir:bp, A	3	4	2 × (b)	bit (dir:bp) b ← (A)	—	—	—	—	—	*	*	—	—	*
MOVB addr16:bp, A	4	4	2 × (b)	bit (addr16:bp) b ← (A)	—	—	—	—	—	*	*	—	—	*
MOVB io:bp, A	3	4	2 × (b)	bit (io:bp) b ← (A)	—	—	—	—	—	*	*	—	—	*
SETB dir:bp	3	4	2 × (b)	bit (dir:bp) b ← 1	—	—	—	—	—	—	—	—	—	*
SETB addr16:bp	4	4	2 × (b)	bit (addr16:bp) b ← 1	—	—	—	—	—	—	—	—	—	*
SETB io:bp	3	4	2 × (b)	bit (io:bp) b ← 1	—	—	—	—	—	—	—	—	—	*
CLRB dir:bp	3	4	2 × (b)	bit (dir:bp) b ← 0	—	—	—	—	—	—	—	—	—	*
CLRB addr16:bp	4	4	2 × (b)	bit (addr16:bp) b ← 0	—	—	—	—	—	—	—	—	—	*
CLRB io:bp	3	4	2 × (b)	bit (io:bp) b ← 0	—	—	—	—	—	—	—	—	—	*
BBC dir:bp, rel	4	*1	(b)	Branch if (dir:bp) b = 0	—	—	—	—	—	—	*	—	—	—
BBC addr16:bp, rel	5	*1	(b)	Branch if (addr16:bp) b = 0	—	—	—	—	—	—	*	—	—	—
BBC io:bp, rel	4	*1	(b)	Branch if (io:bp) b = 0	—	—	—	—	—	—	*	—	—	—
BBS dir:bp, rel	4	*1	(b)	Branch if (dir:bp) b = 1	—	—	—	—	—	—	*	—	—	—
BBS addr16:bp, rel	5	*1	(b)	Branch if (addr16:bp) b = 1	—	—	—	—	—	—	*	—	—	—
BBS io:bp, rel	4	*1	(b)	Branch if (io:bp) b = 1	—	—	—	—	—	—	*	—	—	—
SBBS addr16:bp, rel	5	*2	2 × (b)	Branch if (addr16:bp) b = 1, bit = 1	—	—	—	—	—	—	*	—	—	*
WBTS io:bp	3	*3	*4	Wait until (io:bp) b = 1	—	—	—	—	—	—	—	—	—	—
WBTC io:bp	3	*3	*4	Wait until (io:bp) b = 0	—	—	—	—	—	—	—	—	—	—

Note: For (b), refer to “Table 5 Correction Values for Number of Cycles for Calculating Actual Number of Cycles.”

*1: Set to 5 when branch is executed, and 4 when branch is not executed.

*2: 7 if conditions are met, 6 when conditions are not met.

*3: Indeterminate times

*4: Until conditions are met

MB90210 Series

Table 24 Accumulator Manipulation Instruction (Byte, Word) [6 Instructions]

Mnemonic	#	~	B	Operation	LH	AH	I	S	T	N	Z	V	C	RMW
SWAP	1	3	0	byte (A) 0 – 7 ↔ (A) 8 – 15	–	–	–	–	–	–	–	–	–	–
SWAPW/XCHW AL, AH	1	2	0	word (AH) ↔ (AL)	–	*	–	–	–	–	–	–	–	–
EXT	1	1	0	byte sign-extension	X	–	–	–	–	*	*	–	–	–
EXTW	1	2	0	word sign-extension	–	X	–	–	–	*	*	–	–	–
ZEXT	1	1	0	byte zero-extension	Z	–	–	–	–	R	*	–	–	–
ZEXTW	1	1	0	word zero-extension	–	Z	–	–	–	R	*	–	–	–

Table 25 String Instruction [10 Instructions]

Mnemonic	#	~	B	Operation	LH	AH	I	S	T	N	Z	V	C	RMW
MOVS/MOVS	2	*2	*3	byte transfer @AH + ← @AL +, Counter = RW0	–	–	–	–	–	–	–	–	–	–
MOVSD	2	*2	*3	byte transfer @AH – ← @AL –, Counter = RW0	–	–	–	–	–	–	–	–	–	–
SCEQ/SCEQI	2	*1	*4	byte search (@AH +) – AL, Counter = RW0	–	–	–	–	–	*	*	*	*	–
SCEQD	2	*1	*4	byte search (@AH –) – AL, Counter = RW0	–	–	–	–	–	*	*	*	*	–
FISL/FILSI	2	5m + 6	*5	byte fill @AH + ← AL, Counter = RW0	–	–	–	–	–	*	*	–	–	–
MOVSW/MOVSWI	2	*2	*6	word transfer @AH + ← @AL +, Counter = RW0	–	–	–	–	–	–	–	–	–	–
MOVSWD	2	*2	*6	word transfer @AH – ← @AL –, Counter = RW0	–	–	–	–	–	–	–	–	–	–
SCWEQ/SCWEQI	2	*1	*7	word search (@AH +) – AL, Counter = RW0	–	–	–	–	–	*	*	*	*	–
SCWEQD	2	*1	*7	word search (@AH –) – AL, Counter = RW0	–	–	–	–	–	*	*	*	*	–
FILSW/FILSWI	2	5m + 6	*8	word fill @AH + ← AL, Counter = RW0	–	–	–	–	–	*	*	–	–	–

m: RW0 value (counter value)

*1: 3 when RW0 is 0, 2 + 6 × (RW0) when count out, and 6n + 4 when matched

*2: 4 when RW0 is 0, otherwise 2 + 6 × (RW0)

*3: (b) × (RW0)

*4: (b) × n

*5: (b) × (RW0)

*6: (c) × (RW0)

*7: (c) × n

*8: (c) × (RW0)

Table 26 Multiple Data Transfer Instructions [18 Instruction]

Mnemonic	#	~	B	Operation	LH	AH	I	S	T	N	Z	V	C	RMW
MOVM @A, @RLi, #imm8	3	*1	*3	Multiple data transfer byte ((A)) ← ((RLi))	-	-	-	-	-	-	-	-	-	-
MOVM @A, eam, #imm8	3 +	*2	*3	Multiple data transfer byte ((A)) ← (eam)	-	-	-	-	-	-	-	-	-	-
MOVM addr16, @RLi, #imm8	5	*1	*3	Multiple data transfer byte (addr16) ← ((RLi))	-	-	-	-	-	-	-	-	-	-
MOVM addr16, @eam, #imm8	5 +	*2	*3	Multiple data transfer byte (addr16) ← (eam)	-	-	-	-	-	-	-	-	-	-
MOVMMW@A, @RLi, #imm8	3	*1	*4	Multiple data transfer word ((A)) ← ((RLi))	-	-	-	-	-	-	-	-	-	-
MOVMMW@A, eam, #imm8	3 +	*2	*4	Multiple data transfer word ((A)) ← (eam)	-	-	-	-	-	-	-	-	-	-
MOVMMWaddr16, @RLi, #imm8	5	*1	*4	Multiple data transfer word (addr16) ← ((RLi))	-	-	-	-	-	-	-	-	-	-
MOVMMWaddr16, @eam, #imm8	5 +	*2	*4	Multiple data transfer word (addr16) ← (eam)	-	-	-	-	-	-	-	-	-	-
MOVM @RLi, @A, #imm8	3	*1	*3	Multiple data transfer byte ((RLi)) ← ((A))	-	-	-	-	-	-	-	-	-	-
MOVM @eam, A, #imm8	3 +	*2	*3	Multiple data transfer byte (eam) ← ((A))	-	-	-	-	-	-	-	-	-	-
MOVM @RLi, addr16, #imm8	5	*1	*3	Multiple data transfer byte ((RLi)) ← (addr16)	-	-	-	-	-	-	-	-	-	-
MOVM @eam, addr16, #imm8	5 +	*2	*3	Multiple data transfer byte (eam) ← (addr16)	-	-	-	-	-	-	-	-	-	-
MOVMMW@RLi, @A, #imm8	3	*1	*4	Multiple data transfer word ((RLi)) ← ((A))	-	-	-	-	-	-	-	-	-	-
MOVMMW@eam, A, #imm8	3 +	*2	*4	Multiple data transfer word (eam) ← ((A))	-	-	-	-	-	-	-	-	-	-
MOVMMW@RLi, addr16, #imm8	5	*1	*4	Multiple data transfer word ((RLi)) ← (addr16)	-	-	-	-	-	-	-	-	-	-
MOVMMW@eam, addr16, #imm8	5 +	*2	*4	Multiple data transfer word (eam) ← (addr16)	-	-	-	-	-	-	-	-	-	-
MOVM bnk: addr16, bnk: addr16, #imm8*5	7	*1	*3	Multiple data transfer byte (bnk: addr16) ← (bnk: addr16)	-	-	-	-	-	-	-	-	-	-
MOVMMWbnk: addr16, bnk: addr16, #imm8*5	7	*1	*4	Multiple data transfer word (bnk: addr16) ← (bnk: addr16)	-	-	-	-	-	-	-	-	-	-

*1: 256 when 5 + imm8 × 5, imm8 is 0.

*2: 256 when 5 + imm8 × 5 + (a), imm8 is 0.

*3: (Number of transfer cycles) × (b) × 2

*4: (Number of transfer cycles) × (c) × 2

*5: The bank register specified by bnk is the same as that for the MOVMS instruction.

MB90210 Series

■ ORDERING INFORMATION

Part number	Type	Package	Remarks
MB90214 MB90P214A MB90P214B	MB90214PF MB90P214PF MB90P214BPF	80-pin Plastic QFP (FPT-80P-M06)	
MB90W214A MB90W214B	MB90W214ZF MB90W214BZF	80-pin Ceramic QFP (FPT-80C-C02)	Only ES level
MB90V210	MB90V210CR	256-pin Ceramic PGA (PGA-256C-A02)	For evaluation

MEMO

MEMO



MB90210 Series

FUJITSU LIMITED

For further information please contact:

Japan

FUJITSU LIMITED
Corporate Global Business Support Division
Electronic Devices
KAWASAKI PLANT, 4-1-1, Kamikodanaka
Nakahara-ku, Kawasaki-shi
Kanagawa 211-88, Japan
Tel: (044) 754-3763
Fax: (044) 754-3329

<http://www.fujitsu.co.jp/>

North and South America

FUJITSU MICROELECTRONICS, INC.
Semiconductor Division
3545 North First Street
San Jose, CA 95134-1804, U.S.A.
Tel: (408) 922-9000
Fax: (408) 922-9179

Customer Response Center
Mon. - Fri.: 7 am - 5 pm (PST)
Tel: (800) 866-8608
Fax: (408) 922-9179

<http://www.fujitsumicro.com/>

Europe

FUJITSU MIKROELEKTRONIK GmbH
Am Siebenstein 6-10
D-63303 Dreieich-Buchsschlag
Germany
Tel: (06103) 690-0
Fax: (06103) 690-122

<http://www.fujitsu-edc.com/>

Asia Pacific

FUJITSU MICROELECTRONICS ASIA PTE LTD
#05-08, 151 Lorong Chuan
New Tech Park
Singapore 556741
Tel: (65) 281-0770
Fax: (65) 281-0220

<http://www.fmap.com.sg/>

F9710

© FUJITSU LIMITED Printed in Japan

All Rights Reserved.

The contents of this document are subject to change without notice. Customers are advised to consult with FUJITSU sales representatives before ordering.

The information and circuit diagrams in this document presented as examples of semiconductor device applications, and are not intended to be incorporated in devices for actual use. Also, FUJITSU is unable to assume responsibility for infringement of any patent rights or other rights of third parties arising from the use of this information or circuit diagrams.

FUJITSU semiconductor devices are intended for use in standard applications (computers, office automation and other office equipment, industrial, communications, and measurement equipment, personal or household devices, etc.).

CAUTION:

Customers considering the use of our products in special applications where failure or abnormal operation may directly affect human lives or cause physical injury or property damage, or where extremely high levels of reliability are demanded (such as aerospace systems, atomic energy controls, sea floor repeaters, vehicle operating controls, medical devices for life support, etc.) are requested to consult with FUJITSU sales representatives before such use. The company will not be responsible for damages arising from such use without prior approval.

Any semiconductor devices have inherently a certain rate of failure. You must protect against injury, damage or loss from such failures by incorporating safety design measures into your facility and equipment such as redundancy, fire protection, and prevention of over-current levels and other abnormal operating conditions.

If any products described in this document represent goods or technologies subject to certain restrictions on export under the Foreign Exchange and Foreign Trade Control Law of Japan, the prior authorization by Japanese government should be required for export of those products from Japan.

