

TOSHIBA Bipolar Linear Integrated Circuit Silicon Monolithic

TA8186P

AM / FM IF + MPX

TA8186P is the AM / FM IF + MPX system IC, which is designed for radio cassette recorders and music centers.

Features

- Compact package (DIP16), and small number of external parts.
- AM IFT is also used for VCO resonator.
- Built-in FM soft muting circuit.
- Operating supply voltage range:
 $V_{CC(opr)} = 3.5\sim 13V$ ($T_a = 25^\circ C$)
 At FM soft mute using:
 $V_{CC(opr)} = 3.5\sim 9V$ ($T_a = 25^\circ C$)

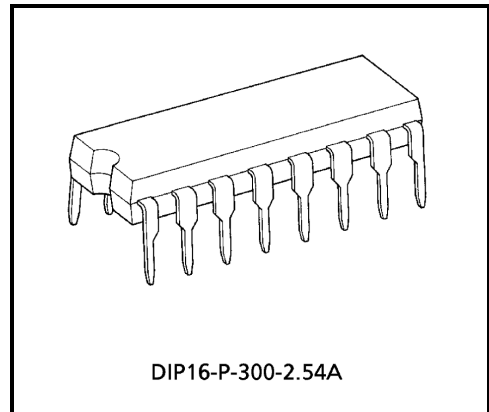

DIP16-P-300-2.54A

Weight: 1.00g (typ.)

※Handle with care to prevent devices from deteriorations by static electricity.

Block Diagram

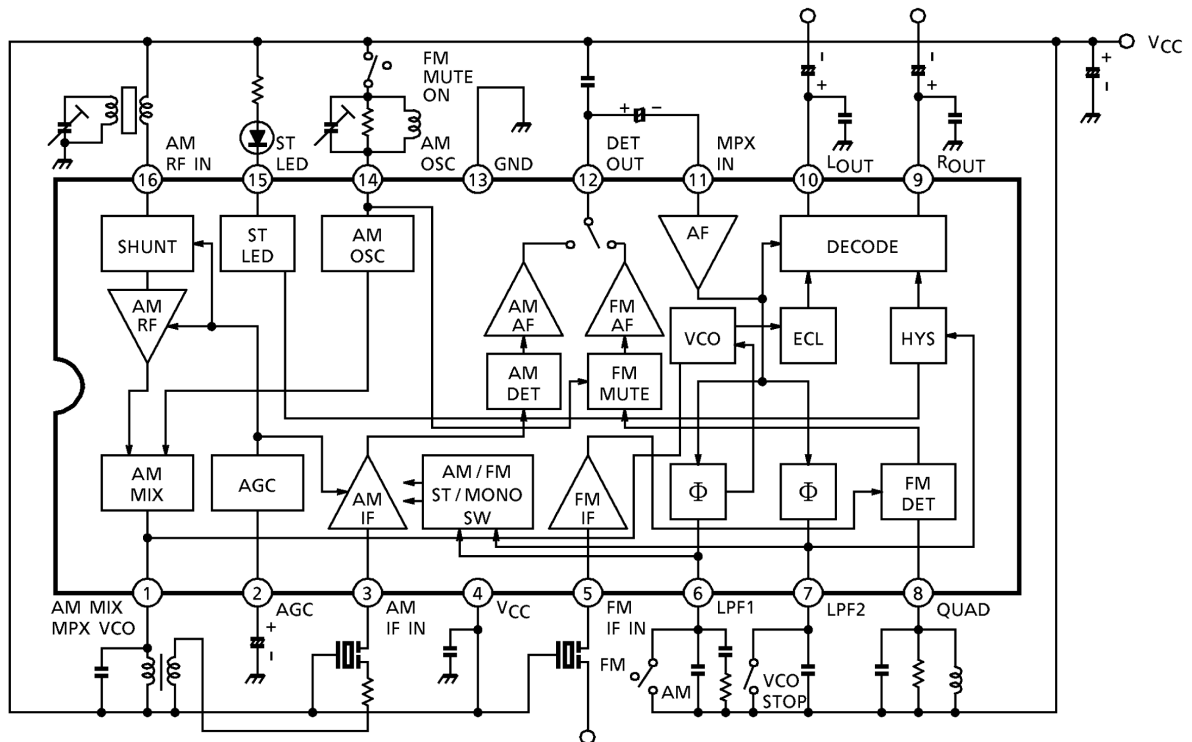

Terminal Explanation (terminal voltage shows the typical value at $T_a = 25^\circ\text{C}$, $V_{CC} = 6\text{V}$, and non-signal test circuit)

Pin No.	Terminal Name	Contents	Internal Circuit	Terminal Voltage(V)	
				FM	AM
1	AM mix MPX VCO	<ul style="list-style-type: none"> • AM mixer output terminal • AM IFT is also used for VCO resonator 		6.0	6.0
2	AGC	AM AGC terminal It is necessary to connect external capacitance		0.4	0.3
3	AM IF in	AM IF amp input terminal		6.0	6.0
4	V_{CC}	Power supply	—	6.0	6.0
5	FM IF in	FM IF amp input terminal		6.0	6.0
6	LPF1	<ul style="list-style-type: none"> • LPF terminal for phase detector • Bias terminal for AM / FM switch circuit $V_6 = V_{CC} \rightarrow \text{AM}$ $V_6 = \text{open} \rightarrow \text{FM}$ 		4.3 (at VCO stop 5.6)	6.0

Pin No.	Terminal Name	Contents	Internal Circuit	Terminal Voltage(V)	
				FM	AM
7	LPF2	<ul style="list-style-type: none"> • LPF terminal for synchronous detector • VCO stop terminal $V_7 = V_{CC} \rightarrow$ VCO stop 		4.3	6.0
8	QUAD	FM QUAD detector terminal FM QUAD coil is connected.		6.0	6.0
9	R _{out}	MPX audio output terminal		3.5	3.5
10	L _{out}			3.5	3.5
11	MPX in	MPX input terminal		3.3	3.3
12	DET out	FM / AM detector output terminal		1.3	1.3
13	GND	GND terminal	—	0	0

Pin No.	Terminal Name	Contents	Internal Circuit	Terminal Voltage(V)	
				FM	AM
14	AM OSC	<ul style="list-style-type: none"> • AM OCS terminal • Bias terminal for FM soft mute switch circuit $V_{14} = \text{open} \rightarrow \text{FM mute on}$		6.0 (at FM mute on 5.4)	6.0
15	St LED	<ul style="list-style-type: none"> • Stereo LED terminal • VCO monitor terminal 		5.4	5.4
16	AM RF in	AM RF amp input terminal ($R_{in} = 1M\Omega$, at $f_{in} = 1\text{MHz}$)		6.0	6.0

Maximum Ratings ($T_a = 25^\circ\text{C}$)

Characteristic	Symbol	Rating	Unit
Supply voltage	V_{CC}	15	V
LED current	I_{LED}	10	mA
LED voltage	V_{LED}	15	V
Power dissipation	P_D (Note)	750	mW
Operating temperature	T_{opr}	-25~75	$^\circ\text{C}$
Storage temperature	T_{stg}	-55~150	$^\circ\text{C}$

(Note) Derated above $T_a = 25^\circ\text{C}$ in the proportion of $6\text{mW} / ^\circ\text{C}$.

Electrical Characteristics

Unless Otherwise Specified, $T_a = 25^\circ\text{C}$, $V_{CC} = 6\text{V}$,

FM IF: $f = 10.7\text{MHz}$, $\Delta f = \pm 22.5\text{kHz}$, $f_m = 1\text{kHz}$

AM: $f = 1\text{MHz}$, $\text{MOD} = 30\%$, $f_m = 1\text{kHz}$

MPX: $f_m = 1\text{kHz}$

Characteristic		Symbol	Test Cir-cuit	Test Condition	Min.	Typ.	Max.	Unit		
Supply current		$I_{CC}(\text{FM})$	1	FM mode, $V_{in} = 0$	—	17.0	25.0	mA		
		$I_{CC}(\text{AM})$	1	AM mode, $V_{in} = 0$	—	15.0	22.0			
FM IF	Input limiting voltage	$V_{in}(\text{lim})$	1	-3dB limiting point	38	43	48	dB μV EMF		
	Recovered output voltage	V_{OD}	1	$V_{in} = 80\text{dB}\mu\text{V}$ EMF	55	80	110	mV $_{\text{rms}}$		
	Signal to noise ratio	S / N	1	$V_{in} = 80\text{dB}\mu\text{V}$ EMF	—	70	—	dB		
	Total harmonic distortion	THD	1	$V_{in} = 80\text{dB}\mu\text{V}$ EMF	—	0.1	—	%		
	AM rejection ratio	AMR	1	$V_{in} = 80\text{dB}\mu\text{V}$ EMF	—	45	—	dB		
AM	Gain	G_V	1	$V_{in} = 26\text{dB}\mu\text{V}$ EMF	20	35	50	mV $_{\text{rms}}$		
	Recovered output voltage	V_{OD}	1	$V_{in} = 60\text{dB}\mu\text{V}$ EMF	55	80	110	mV $_{\text{rms}}$		
	Signal to noise ratio	S / N	1	$V_{in} = 60\text{dB}\mu\text{V}$ EMF	—	42	—	dB		
	Total harmonic distortion	THD	1	$V_{in} = 60\text{dB}\mu\text{V}$ EMF	—	1.0	—	%		
Pin (12) output resistance		R_{12}	1	FM mode	—	1.5	—	k Ω		
				AM mode	—	10	—			
MPX	Input resistance		R_{IN}	1	—	33	—	k Ω		
	Output resistance		R_{OUT}	1	—	5	—			
	Max. Composite signal input voltage		$V_{in \text{ max}}$ (stereo)	1	L + R = 90%, P = 10% THD = 3%, SW \rightarrow LPF: On	—	800	—	mV $_{\text{rms}}$	
	Separator		Sep	1	L + R = 180mV $_{\text{rms}}$ P = 20mV $_{\text{rms}}$ SW \rightarrow LPF: On	$f_m = 100\text{Hz}$	—	43	—	dB
						$f_m = 1\text{kHz}$	35	43	—	
						$f_m = 10\text{kHz}$	—	43	—	
	Total harmonic distortion	Monaural	THD (monaural)	1	$V_{in} = 200\text{mV}_{\text{rms}}$ (mono)	—	0.2	—	%	
Stereo		THD (stereo)	L + R = 180mV $_{\text{rms}}$ P = 20mV $_{\text{rms}}$ SW \rightarrow LPF: On							—
Voltage gain		$G_V(\text{MPX})$	1	$V_{in} = 200\text{mV}_{\text{rms}}$ (mono)	-2	0	2	dB		
Channel balance		C. B.	1	$V_{in} = 200\text{mV}_{\text{rms}}$ (mono)	-2	0	2	dB		

Characteristic		Symbol	Test Circuit	Test Condition	Min.	Typ.	Max.	Unit	
MPX	Stereo LED sensitivity	On	V_L (ON)	1	Pilot input	—	10	16	mV_{rms}
		Off	V_L (OFF)			2	6	—	
	Stereo LED hysteresis		V_H	1	To LED turn off from LED turn on	—	4	—	mV_{rms}
	Capture range		C. R.	1	$P = 20mV_{rms}$	—	± 4	—	%
	Signal to noise ratio		S / N	1	$V_{in} = 200mV_{rms}$ (mono)	—	78	—	dB

Test Circuit

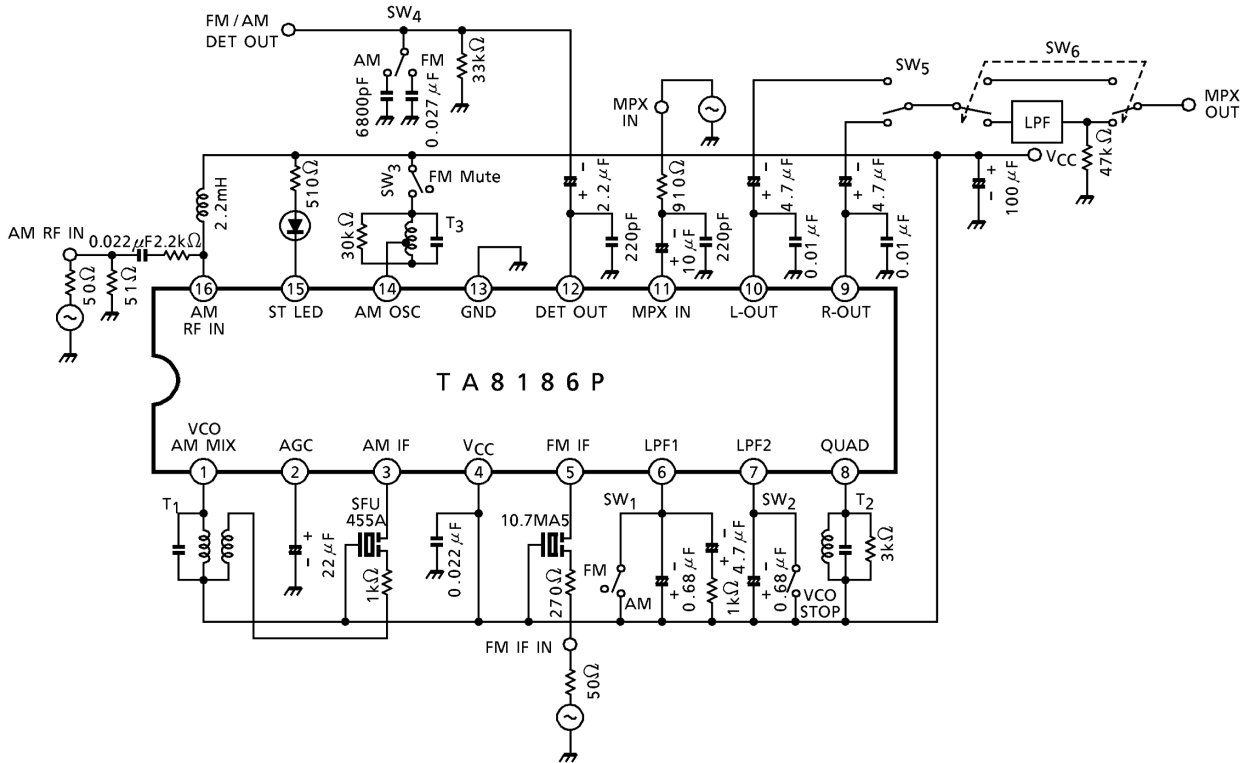

Coil Data

Coil No.	F	L (µH)	C ₀ (pF)	Q ₀	Turn				Wire (mmφ)	Ref
					1-2	2-3	1-3	4-6		
T ₁ AM IFT	455kHz	—	180	120	—	—	180	15	0.06 UEW	(S) 2150-2162-165
		—	180	50↑	—	—	158	14	0.07φ2 UEW	(T) A7LCS-11432X
T ₂ FM DET	10.7MHz	—	82	110	—	—	13	—	0.12 UEW	(S) 4152-4095-015
		—	82	80↑	—	—	11	—	0.1φ2 UEW	(T) A119ACS-19118Z
T ₃ AM OSC	796kHz	288	—	115	13	73	—	—	0.08 UEW	(S) 4147-1356-038
		288	—	105↑	16	88	—	—	0.07φ2 UEW	(T) 7TRS-11433Y

(S): SUMIDA ELECTRIC Co., Ltd.

(T): TOKO Co., Ltd.

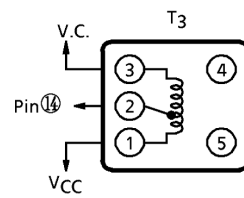
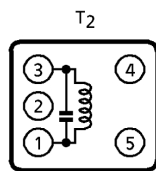
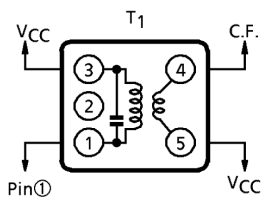

Package Dimensions

DIP16-P-300-2.54A

Unit : mm

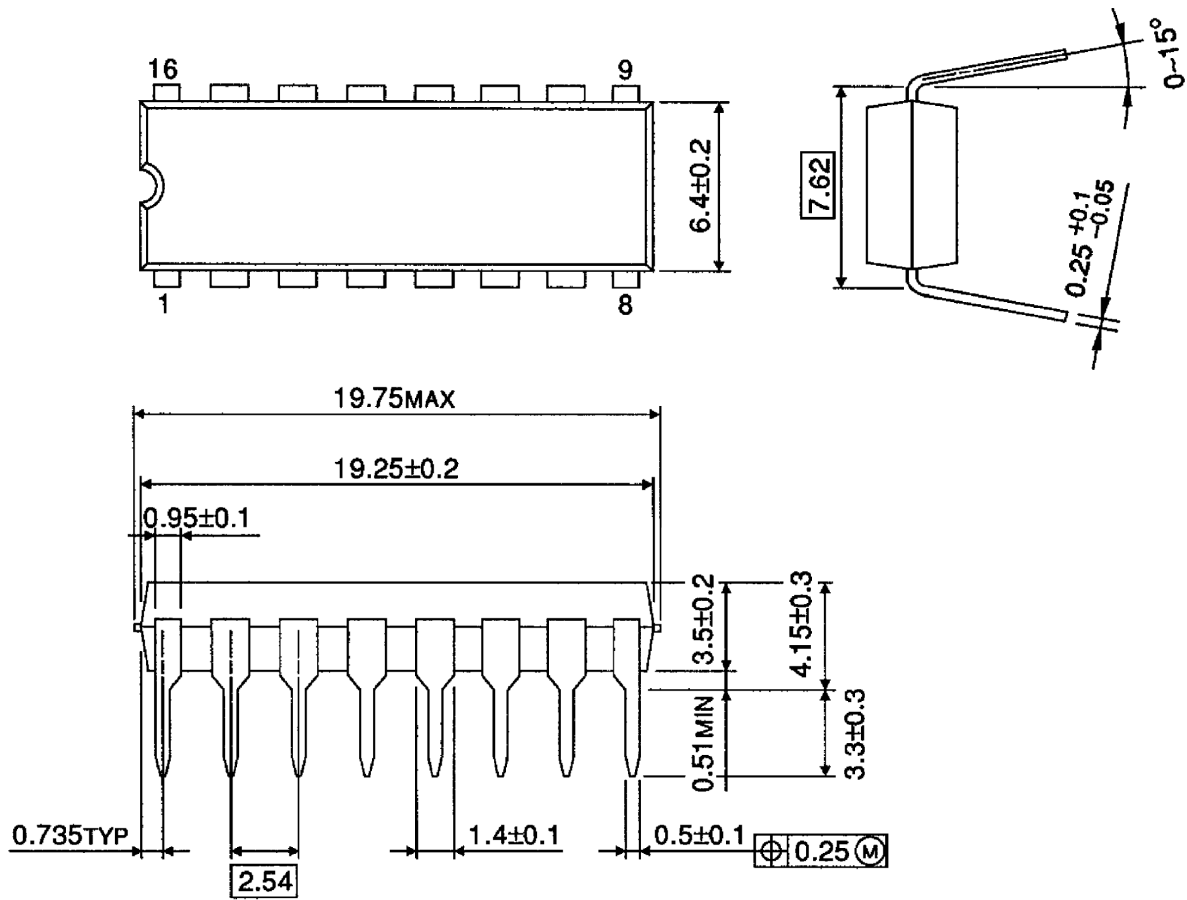

Weight: 1.00g (typ.)

RESTRICTIONS ON PRODUCT USE

000707EBA

- TOSHIBA is continually working to improve the quality and reliability of its products. Nevertheless, semiconductor devices in general can malfunction or fail due to their inherent electrical sensitivity and vulnerability to physical stress. It is the responsibility of the buyer, when utilizing TOSHIBA products, to comply with the standards of safety in making a safe design for the entire system, and to avoid situations in which a malfunction or failure of such TOSHIBA products could cause loss of human life, bodily injury or damage to property.
In developing your designs, please ensure that TOSHIBA products are used within specified operating ranges as set forth in the most recent TOSHIBA products specifications. Also, please keep in mind the precautions and conditions set forth in the "Handling Guide for Semiconductor Devices," or "TOSHIBA Semiconductor Reliability Handbook" etc..
- The TOSHIBA products listed in this document are intended for usage in general electronics applications (computer, personal equipment, office equipment, measuring equipment, industrial robotics, domestic appliances, etc.). These TOSHIBA products are neither intended nor warranted for usage in equipment that requires extraordinarily high quality and/or reliability or a malfunction or failure of which may cause loss of human life or bodily injury ("Unintended Usage"). Unintended Usage include atomic energy control instruments, airplane or spaceship instruments, transportation instruments, traffic signal instruments, combustion control instruments, medical instruments, all types of safety devices, etc.. Unintended Usage of TOSHIBA products listed in this document shall be made at the customer's own risk.
- The products described in this document are subject to the foreign exchange and foreign trade laws.
- The information contained herein is presented only as a guide for the applications of our products. No responsibility is assumed by TOSHIBA CORPORATION for any infringements of intellectual property or other rights of the third parties which may result from its use. No license is granted by implication or otherwise under any intellectual property or other rights of TOSHIBA CORPORATION or others.
- The information contained herein is subject to change without notice.