

Agilent N7788B/BD Optical Component Analyzer

Data Sheet



Figure 1. N7788BD bench-top mainframe with built-in PC



Figure 2. N7788B bench-top mainframe

Introduction

Agilent Technologies pushes the limits of component measurements with the N7788B component analyzer. Its proprietary technology is comparable with the well-known **Jones-Matrix-Eigenanalysis (JME)** which is the standard method for measuring polarization mode dispersion (PMD) or differential group delay (DGD) of optical devices.

Compared to the JME, Agilent's new **single scan technology** offers a range of advantages:

A complete set of parameters:

- DGD/PMD
- PDL
- Power/loss
- TE/TM-loss
- Jones matrices
- Mueller matrices
- 2nd-order PMD (depolarization + PCD)
- Principal states of polarization (PSPs)

Key Benefits

- **Highest accuracy** in a single sweep: no averaging over multiple sweeps required
- **High measurement speed:** Complete measurement across C/L-band in less than 10 seconds (no need to wait for many averages)
- **Robustness** against fiber movement/vibration and drift: Fixing fibers with sticky tape on the table or even operation on isolated optical table is not required!
- **No limitation on optical path length** of component
- The **internal referencing scheme** guarantees reliable and accurate measurements.



Applications

- Fiber characterization: SMF, PMF, DCF
- Passive component testing: filters, isolators, circulators
- Dynamic component / module testing: OADM / ROADM
- Active component testing: EDFAs, SOAs, VOAs
- Link test: in-channel measurements across amplifiers

Designed for the manufacturing floor

High throughput

A complete analysis across the C and the L band is performed in less than 10 seconds!

Software drivers

A range of software drivers is available for external control of the system. This allows easy integration in common ERP systems.

Remote control

Control of the instrument through LAN or via the Internet is supported. This supports automation as well as trouble shooting.

Report generation

Generating PDF reports is supported. The content including layout is configurable by the user.

Real time power readout

High throughput measurement of non-connectorized components is supported by providing a real time power readout which enables fiber coupling of the new device

Barcode scanner

Barcode scanning is supported for quick transfer of the DUT serial number

The instrument setup is shown in the Figure 3. A LiNbO₃ polarization controller determines the input polarization to the DUT. While the tunable laser source is sweeping over the desired wavelength range, a polarimeter analyzes the output state of polarization while input polarization is being modified. The result will be a highly accurate device characterization with respect to DGD/PDL/loss, etc. Furthermore, the internal optical switch provides continuous self calibration for excellent repeatability.

Resolving TE/TM insertion loss

The TE/TM-function allows accurate determination of the minimum and maximum loss of the DUT at each wavelength.

Due to birefringence, optical filters tend to show different transmission functions depending on the polarization state. As shown in Figure 4, these functions are typically shifted in wavelength depending on the amount of birefringence.

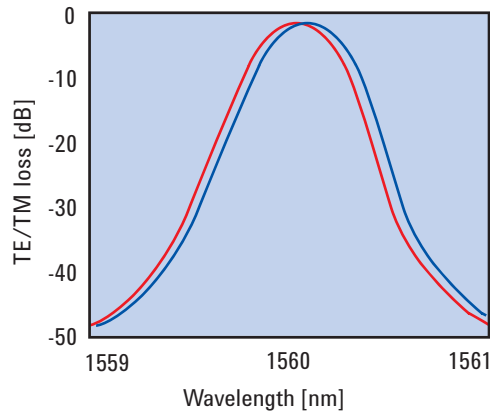

Figure 4. Polarization-dependent wavelength shift (PD-A) of a filter.

The capability of performing quick PMD-measurements makes this measurement system well-suited for collecting long-term PMD data. The PC software allows to continuously collect the spectral PMD data and store it on the hard disc. The data can then be visualized as pseudo-color plot (see Figure 5).

Agilent N7788B Instrument Setup and Application Examples

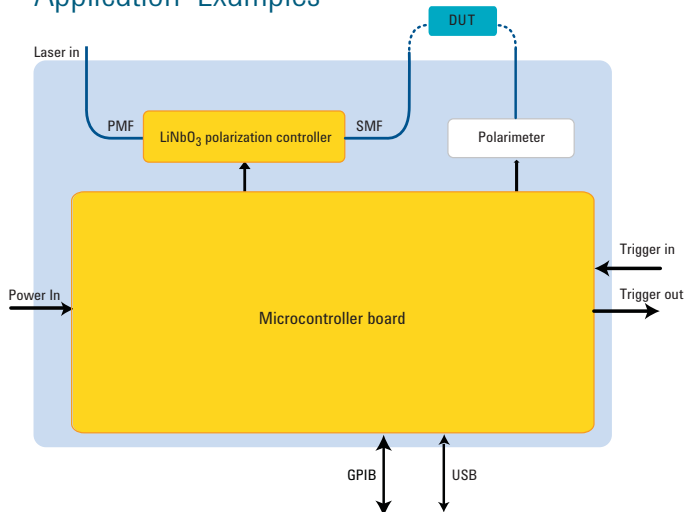

Figure 3. Instrument setup

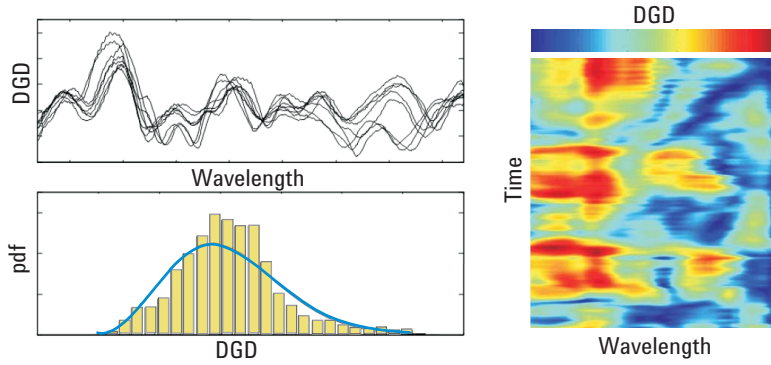

Figure 5. Long term DGD measurements.

Particularly for characterizing optical filters, the high dynamic range of the N7788B allows accurate resolution of the filter's side lobes.

The internal reference path allows measurement of insertion loss spectra with excellent accuracy, minimizing the influence of the power characteristics of the tunable laser source.

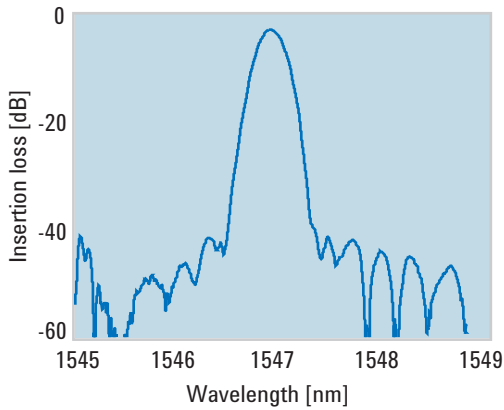

Figure 6. Side lobes of an optical filter.

Due to the excellent spectral resolution, the Agilent N7788B is best suited for intra-channel DGD/PDL characterization.

The all-parameter-JME algorithm allows flexible adjustments of the wavelength resolution without the need to repeat the measurement. This allows the user to easily find the optimum trade-off between PDL/DGD accuracy and wavelength resolution.

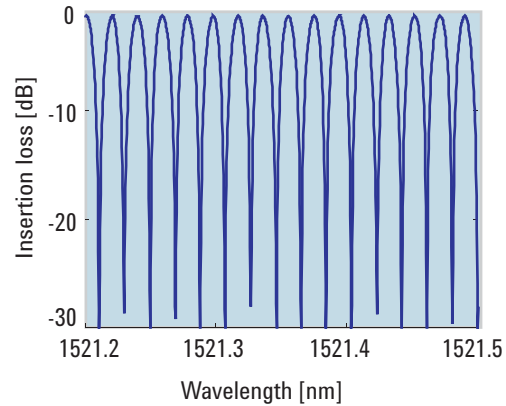

Figure 7. Loss curve of a DPSK demodulator.

Table 1: Specifications¹⁾ N7788B/BD Optical Component Analyzer

Wavelength		
Specification wavelength range	1270 nm ... 1375 nm (Opt 300, O-Band) 1270 nm ... 1375 nm, 1460 nm ... 1620 nm (Opt 400, O/C/L-Band) 1460 nm ... 1620 nm (Opt 500, C/L-Band)	
Operating wavelength range ²⁾	1260 nm ... 1640 nm	
Differential Delay		
DGD uncertainty	Resolution 2,0 nm:	$\pm (30 \text{ fs} + 0.3\% \cdot \text{DGD})$
	Resolution 0,1 nm:	$\pm (30 \text{ fs} + 3.0\% \cdot \text{DGD})$
DGD measurement range ³⁾	0 ... 1000 ps	
PMD uncertainty ⁴⁾	$\pm(30 \text{ fs} + 2.0\% \cdot \text{DGD})$	
PMD repeatability (typical)	$\pm 3 \text{ fs}$	
PMD measurement range ⁴⁾	0 ... 300 ps	
Loss		
PDL uncertainty (typical) ⁵⁾	C/L-Band:	$\pm (0.05 \text{ dB} + 4\% \cdot \text{PDL})$
	O-Band:	$\pm (0.05 \text{ dB} + 4\% \cdot \text{PDL})$
PDL repeatability (typical)	$\pm 5 \text{ m dB}$	
Insertion loss uncertainty (typical) ³⁾	C/L-Band:	$\pm 0.03 \text{ dB}$
	O-Band:	$\pm 0.07 \text{ dB}$
Insertion loss dynamic range (typical) ³⁾	> 41 dB (for higher TLS power levels, increase value accordingly)	
Polarization Analysis		
See N7781B		

1) Ambient temperature change max $\pm 0.5^\circ\text{C}$ since normalization. Valid for 81600B Tunable Laser Source Family. TLS power set to -6 dBm. Sweep over specification wavelength range. Specification does not include instability in test device. Specified loss ranges include loss of test device and any additional switches or connections in the optical path. Specification valid on day of calibration.

2) SOP/DOP measurements are only possible outside the specification wavelength range if the user performs a manual calibration.

3) DUT properties: Insertion loss < 30 dB, PDL < 1 dB, DGD < 150 ps. Specification is typical for DGD > 150 ps.

4) DUT properties: Insertion loss < 41 dB, PDL < 3 dB, PMD < 50 ps. Applies for highly mode-coupled devices such as single mode fibers. Specification applies for PMD being averaged DGD over a wavelength span of 100 nm. Specification is typical for PMD < 50 ps.

5) DUT properties: Insertion loss < 25 dB, PDL < 6 dB. Note: DUT connectors are considered as being part of the DUT. Thus, angled connectors will add to the device PDL.

Remove all doubt

Our repair and calibration services will get your equipment back to you, performing like new, when promised. You will get full value out of your Agilent equipment throughout its lifetime. Your equipment will be serviced by Agilent-trained technicians using the latest factory calibration procedures, automated repair diagnostics and genuine parts. You will always have the utmost confidence in your measurements.

Agilent offers a wide range of additional expert test and measurement services for your equipment, including initial start-up assistance onsite education and training, as well as design, system integration, and project management.

For more information on repair and calibration services, go to:

www.agilent.com/find/removealldoubt



Agilent Email Updates

www.agilent.com/find/emailupdates

Get the latest information on the products and applications you select.



Agilent Direct

www.agilent.com/find/agilentdirect

Quickly choose and use your test equipment solutions with confidence.

www.agilent.com

For more information on Agilent Technologies' products, applications or services, please contact your local Agilent office. The complete list is available at:

www.agilent.com/find/contactus

Americas

Canada	(877) 894-4414
Latin America	305 269 7500
United States	(800) 829-4444

Asia Pacific

Australia	1 800 629 485
China	800 810 0189
Hong Kong	800 938 693
India	1 800 112 929
Japan	81 426 56 7832
Korea	080 769 0800
Malaysia	1 800 888 848
Singapore	1 800 375 8100
Taiwan	0800 047 866
Thailand	1 800 226 008

Europe

Austria	0820 87 44 11
Belgium	32 (0) 2 404 93 40
Denmark	45 70 13 15 15
Finland	358 (0) 10 855 2100
France	0825 010 700
Germany	01805 24 6333* *0.14€/minute
Ireland	1890 924 204
Italy	39 02 92 60 8 484
Netherlands	31 (0) 20 547 2111
Spain	34 (91) 631 3300
Sweden	0200-88 22 55
Switzerland (French)	41 (21) 8113811(Option 2)
Switzerland (German)	0800 80 53 53 (Option 1)
United Kingdom	44 (0) 118 9276201

Other European Countries:

www.agilent.com/find/contactus

Revised: May 7, 2007

Product specifications and descriptions in this document subject to change without notice.

© Agilent Technologies, Inc. 2008

Printed in USA, April 29, 2008

5989-8116EN



Agilent Technologies