



High-/Full-Speed USB 2.0 Switches

General Description

The MAX4906/MAX4906F/MAX4907/MAX4907F analog switches combine the low on-capacitance (C_{ON}) and low on-resistance (R_{ON}) necessary for high-performance switching applications. These devices are designed for USB 2.0 high-speed applications at 480Mbps. These switches will also handle all the requirements for USB low- and full-speed signaling.

The MAX4906/MAX4906F feature two single-pole/double-throw (SPDT) switches, and the MAX4907/MAX4907F feature two single-pole/single-throw switches (SPST). The MAX4907/MAX4907F have a low 7Ω (max) on-resistance and 7pF (max) on-capacitance. These devices are fully specified to operate from a single $+3.0\text{V}$ to $+3.6\text{V}$ power supply and are protected against a $+5.5\text{V}$ short to COM1 and COM2. This feature makes them fully compliant with the USB 2.0 specification of $+5.5\text{V}$ fault protection. These devices feature a low threshold voltage and a $+1.4\text{V}$ V_{IH} , permitting them to be used with low-voltage logic. The MAX4906/MAX4906F/MAX4907/MAX4907F operate at $300\mu\text{A}$ (max) quiescent current and feature a shutdown input to reduce the quiescent current to less than $2\mu\text{A}$ (max).

The MAX4906/MAX4906F/MAX4907/MAX4907F are available in space-saving, $2\text{mm} \times 2\text{mm}$ μDFN packages and operate over a -40°C to $+85^\circ\text{C}$ temperature range.

Applications

Cell Phones	USB Switching
PDA's	Ethernet Switching
Digital Still Cameras	Video Switching
GPS	Bus Switches
Notebook Computers	T3/E3 Switches for
Relay Replacements	Redundancy Protection

Typical Operating Characteristics

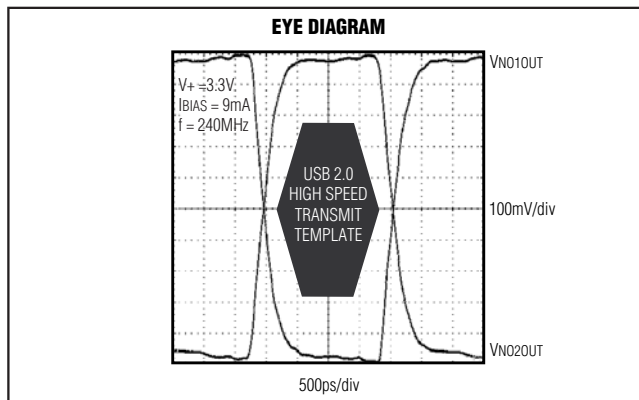

Features

- ◆ Fully Specified for a Single $+3.0\text{V}$ to $+3.6\text{V}$ Power-Supply Voltage
- ◆ Low 4Ω (typ), 7Ω (max) On-Resistance (R_{ON})
- ◆ MAX4907/MAX4907F Ultra-Low 4pF (typ), 7pF (max) On-Capacitance (C_{ON})
- ◆ -3dB Bandwidth: 1GHz (typ)
- ◆ Low Bit-to-Bit Skew $\leq 100\text{ps}$
- ◆ Shutdown Input Reduces Power Consumption to $2\mu\text{A}$ (max)
- ◆ 3.3V , 1.8V , and 1.4V Logic Compatible
- ◆ COM Analog Inputs Fault Protected Against Shorts to USB Supply Rail Up to $+5.5\text{V}$
- ◆ Space-Saving Packages
8-Pin and 10-Pin, $2\text{mm} \times 2\text{mm}$ μDFN Packages

Ordering Information

PART	PIN-PACKAGE	PKG CODE
MAX4906ELB	10 μDFN	L1022-1
MAX4906FELB	10 μDFN	L1022-1
MAX4907ELA	8 μDFN	L822-1
MAX4907FELA	8 μDFN	L822-1

Note: All devices operate over the -40°C to $+85^\circ\text{C}$ operating temperature range.

Selector Guide appears at end of data sheet.

Pin Configurations

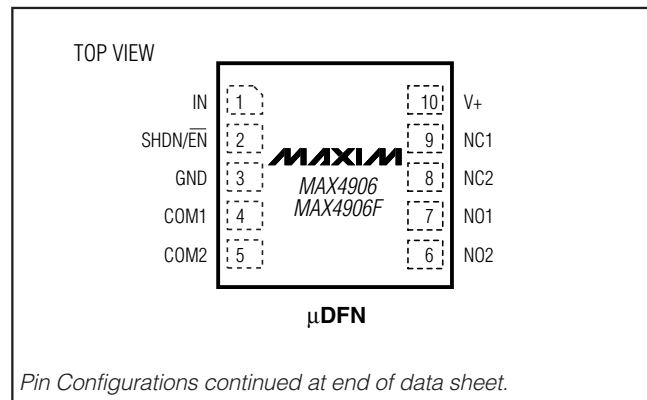

Pin Configurations continued at end of data sheet.



High-/Full-Speed USB 2.0 Switches

ABSOLUTE MAXIMUM RATINGS

Voltages Referenced to GND

V+	-0.3V to +4V
IN, SHDN, SHDN/ $\overline{\text{EN}}$ (Note 1)	-0.3V to (V+ + 0.3V)
COM ₋ , NO ₋ , NC ₋	-0.5V to +5.5V
Continuous Current (COM ₋ to NO ₋ /NC ₋)	±120mA
Peak Current, (COM ₋ to NO ₋ /NC ₋) (pulsed at 1ms 10% duty cycle).....	±240mA

Continuous Power Dissipation (T_A = +70°C)

8-Pin μ DFN (derate 5.0mW/°C above +70°C)	400mW
10-Pin μ DFN (derate 5.3mW/°C above +70°C)	423.7mW
Operating Temperature Range	-40°C to +85°C
Junction Temperature	+150°C
Storage Temperature Range	-65°C to +150°C
Lead Temperature (soldering, 10s)	+300°C

Note 1: Signals on IN, SHDN or SHDN/ $\overline{\text{EN}}$ exceeding V+ or GND are clamped by internal diodes. Limit forward-diode current to maximum current rating.

Stresses beyond those listed under "Absolute Maximum Ratings" may cause permanent damage to the device. These are stress ratings only, and functional operation of the device at these or any other conditions beyond those indicated in the operational sections of the specifications is not implied. Exposure to absolute maximum rating conditions for extended periods may affect device reliability.

ELECTRICAL CHARACTERISTICS

(V+ = +3V to +3.6V, T_A = T_{MIN} to T_{MAX}, unless otherwise noted. Typical values are at V+ = 3.3V, T_A = +25°C.) (Note 2)

PARAMETER	SYMBOL	CONDITIONS	MIN	TYP	MAX	UNITS
ANALOG SWITCH						
Analog Signal Range	V _{COM₋} , V _{NO₋} , V _{NC₋}	SHDN or SHDN/ $\overline{\text{EN}}$ = 0 (Note 3)	0		V+	V
Fault-Protection Trip Threshold	V _{FP}		3.6		4.0	V
On-Resistance	R _{ON}	I _{COM₋} = -40mA, 0V ≤ V _{COM₋} ≤ V+, SHDN or SHDN/ $\overline{\text{EN}}$ = 0		4	7	Ω
		T _A = +25°C				
		T _A = T _{MIN} to T _{MAX}			8	
On-Resistance During Shutdown	R _{ONSH}	I _{COM₋} = -40mA, 0V ≤ V _{COM₋} ≤ 1.5V, SHDN = V+ (MAX4907/MAX4907F)		4	10	Ω
		T _A = +25°C				
		T _A = T _{MIN} to T _{MAX}			13	
On-Resistance Match Between Channels	ΔR _{ON}	V+ = 3.0V, I _{COM₋} = -40mA, V _{COM₋} = 1.5V (Note 4)		0.7	1.2	Ω
		T _A = +25°C				
		T _A = T _{MIN} to T _{MAX}			1.5	
On-Resistance Flatness	R _{FLAT (ON)}	V+ = 3.0V, I _{COM₋} = -40mA, V _{COM₋} = 1.5V, 3.0V (Note 5)		1.0		Ω
Off-Leakage Current	I _{COM₋(OFF)}	V+ = 3.6V, V _{COM₋} = 0.3V, 3.3V; V _{NO₋} or V _{NC₋} = 3.3V, 0.3V	-1		+1	μA
On-Leakage Current	I _{COM₋(ON)}	V+ = 3.6V, V _{COM₋} = 0.3V, 3.3V; V _{NO₋} or V _{NC₋} = 0.3V, 3.3V, or floating	-1		+1	μA
SWITCH AC PERFORMANCE						
On-Channel -3dB Bandwidth	BW	R _L = R _S = 50Ω, signal = 0dBm, Figure 1		1000		MHz
Off-Isolation	V _{ISO}	f = 10MHz; V _{NO₋} , V _{NC₋} = 1VP-P; R _L = R _S = 50Ω, Figure 1		-60		dB
		f = 250MHz; V _{NO₋} , V _{NC₋} = 1VP-P; R _L = R _S = 50Ω, Figure 1		-32		
		f = 500MHz; V _{NO₋} , V _{NC₋} = 1VP-P; R _L = R _S = 50Ω, Figure 1		-26		

High-/Full-Speed USB 2.0 Switches

ELECTRICAL CHARACTERISTICS (continued)

(V+ = +3V to +3.6V, T_A = T_{MIN} to T_{MAX}, unless otherwise noted. Typical values are at V+ = 3.3V, T_A = +25°C.) (Note 2)

PARAMETER	SYMBOL	CONDITIONS	MIN	TYP	MAX	UNITS
Crosstalk (Note 6)	V _{CT}	f = 10MHz; V _{NO_} , V _{NC_} = 1VP-P; R _L = R _S = 50Ω, Figure 1		-59		dB
		f = 250MHz; V _{NO_} , V _{NC_} = 1VP-P; R _L = R _S = 50Ω, Figure 1		-31		
		f = 500MHz; V _{NO_} , V _{NC_} = 1VP-P; R _L = R _S = 50Ω, Figure 1		-25		
SWITCH DYNAMICS						
NO_, NC_ Off-Capacitance	C _(OFF)	f = 1MHz, Figure 2 (Note 7)		2	4	pF
Switch On-Capacitance	C _(ON)	f = 1MHz, Figure 2 (Note 7)	MAX4906ELB, MAX4906FELB	6	9	pF
			MAX4907ELA, MAX4907FELA	4	7	
Switch On-Capacitance Matching	C _{ONM}	f = 1MHz (Note 7)	MAX4906ELB, MAX4906FELB	0.4		pF
			MAX4907ELA, MAX4907FELA	0.3		
Turn-On Time	t _{ON}	V _{NO_} , V _{NC_} = 1.5V; R _L = 300Ω, C _L = 35pF, V _{IH} = V+, V _{IL} = 0V, SHDN or SHDN/ $\overline{\text{EN}}$ = 0V, Figure 3			60	ns
Turn-Off Time	t _{OFF}	V _{NO_} , V _{NC_} = 1.5V; R _L = 300Ω, C _L = 35pF, V _{IH} = V+, V _{IL} = 0V, SHDN or SHDN/ $\overline{\text{EN}}$ = 0V, Figure 3; T _A = +25°C			30	ns
Propagation Delay	t _{PLH_} , t _{PHL}	R _L = R _S = 50Ω, Figure 4		0.25		ns
Fault-Protection Response Time	t _{FP}	V _{COM_} = 0 to 5V step, R _L = R _S = 50Ω, Figure 5			3.0	μs
Fault-Protection Recovery Time	t _{FPR}	V _{COM_} = 5V to 3V step, R _L = R _S = 50Ω, Figure 5			2	μs
Output Skew Between Switches	t _{SK(o)}	Skew between switch 1 and switch 2, R _L = R _S = 50Ω, Figure 4 (Note 7)		50	100	ps
Output Skew Same Switch	t _{SK(p)}	Skew between opposite transitions in same switch, R _L = R _S = 50Ω, Figure 4 (Note 7)		50	100	ps

MAX4906/MAX4606F/MAX4907/MAX4907F

High-/Full-Speed USB 2.0 Switches

ELECTRICAL CHARACTERISTICS (continued)

(V+ = +3V to +3.6V, T_A = T_{MIN} to T_{MAX}, unless otherwise noted. Typical values are at V+ = 3.3V, T_A = +25°C.) (Note 2)

PARAMETER	SYMBOL	CONDITIONS	MIN	TYP	MAX	UNITS
Total Harmonic Distortion Plus Noise	THD+N	V _{COM_L} = 2V _{P-P} , R _L = 600Ω, f = 20Hz to 20kHz		0.03		%
Charge Injection	Q	V _{GEN} = 1.5V, R _{GEN} = 0Ω, C _L = 100pF, Figure 6		5		pC
SWITCH LOGIC						
Logic-Input-Voltage Low	V _{IL}				0.4	V
Logic-Input-Voltage High	V _{IH}		1.1			V
Input-Logic Hysteresis	V _{HYST}			100		mV
Input Leakage Current	I _{IN}	V+ = 3.6V, V _{IN} = 0 or V+	-1		+1	μA
Operating Supply-Voltage Range	V+		3.0		3.6	V
Quiescent Supply Current	I+	V+ = 3.6V, V _{IN} = 0 or V+, SHDN or SHDN/ \overline{EN} = 0		120	300	μA
Quiescent Supply Current During Shutdown	I+	V+ = 3.6V, V _{IN} = 0 or V+, SHDN or SHDN/ \overline{EN} = V+			2	μA

Note 2: All units are 100% production tested at T_A = +25°C. Limits over the operating temperature range are guaranteed by design and not production tested.

Note 3: The switch will turn off for voltages above (V_{FP}); therefore, protecting downstream circuits in case of a fault condition (MAX4906F/MAX4907F).

Note 4: ΔRON(MAX) = |RON(CH1) - RON(CH2)|

Note 5: Flatness is defined as the difference between the maximum and minimum value of on-resistance, as measured over specified analog signal ranges.

Note 6: Between any two switches.

Note 7: Switch off-capacitance, switch on-capacitance, output skew between switches, and output skew same-switch limits are not production tested; design guaranteed by bench characterization.

Typical Operating Characteristics

(T_A = +25°C, unless otherwise noted.)

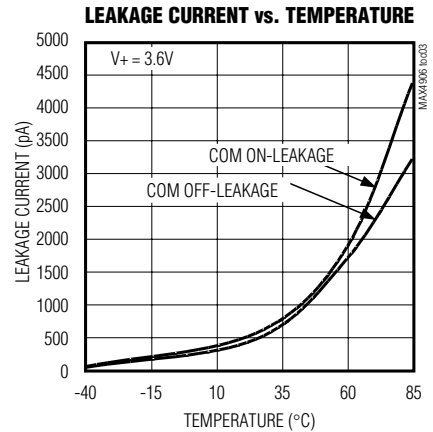
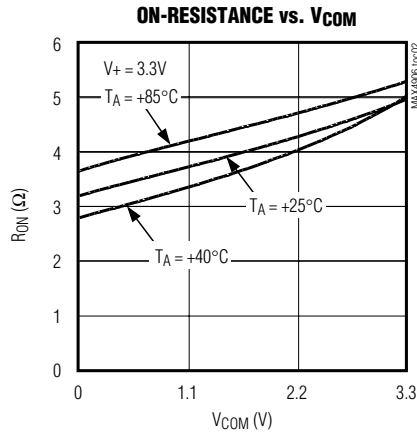
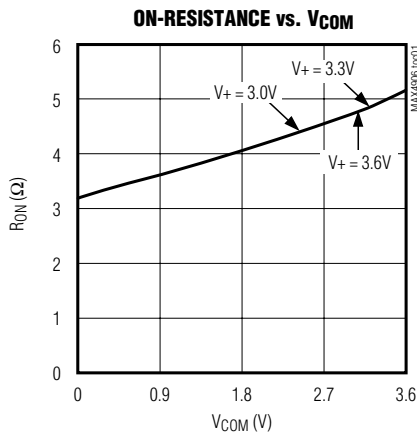

High-/Full-Speed USB 2.0 Switches

Typical Operating Characteristics (continued)

($T_A = +25^\circ\text{C}$, unless otherwise noted.)

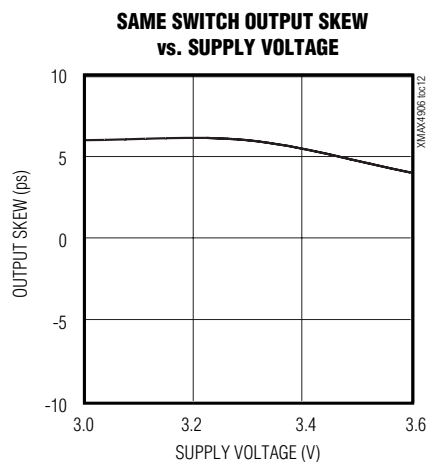
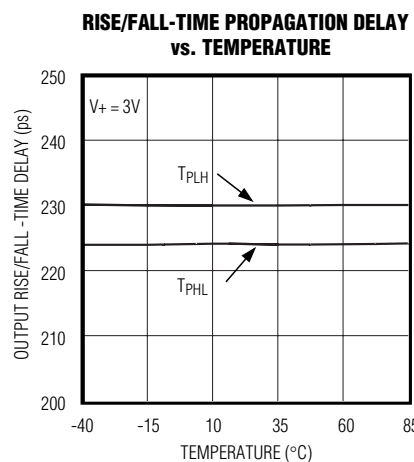
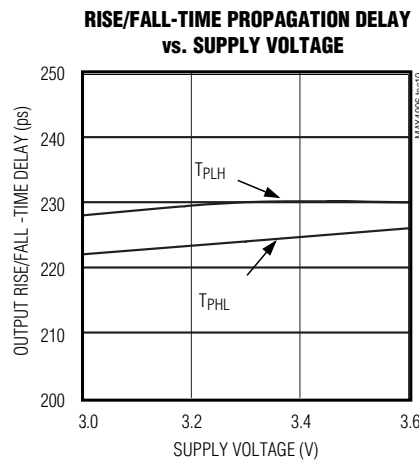
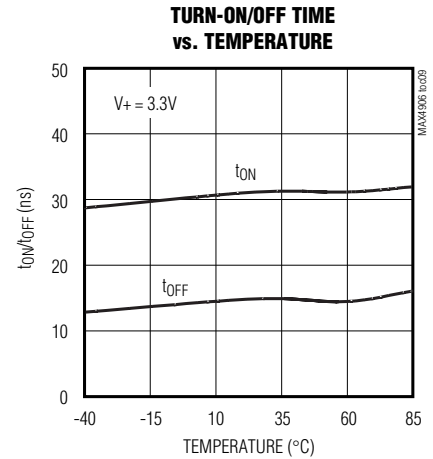
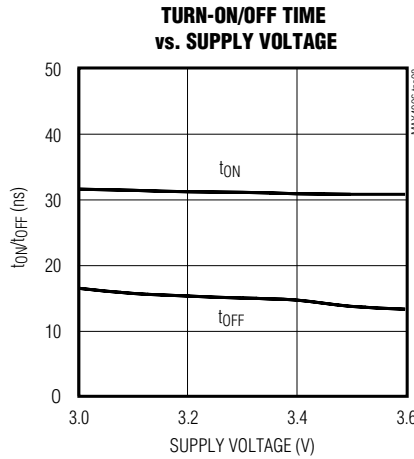
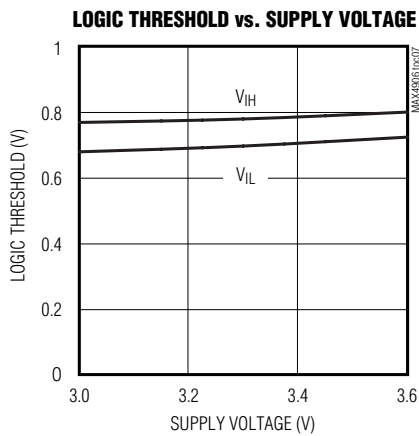
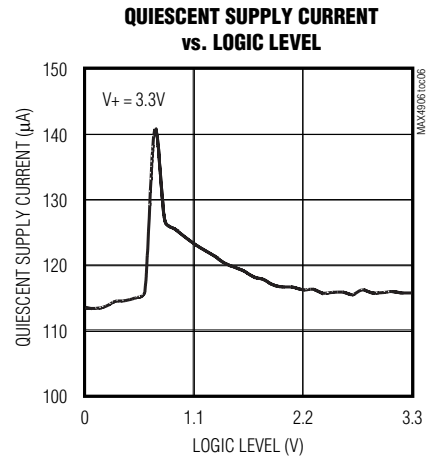
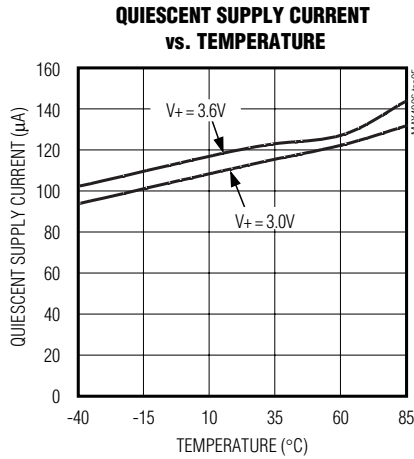
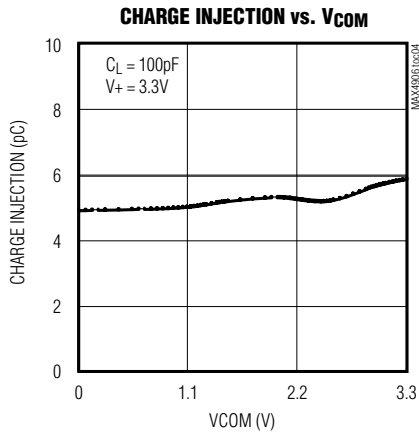

MAX4906/MAX4606F/MAX4907/MAX4907F

High-/Full-Speed USB 2.0 Switches

Typical Operating Characteristics (continued)

(T_A = +25°C, unless otherwise noted.)

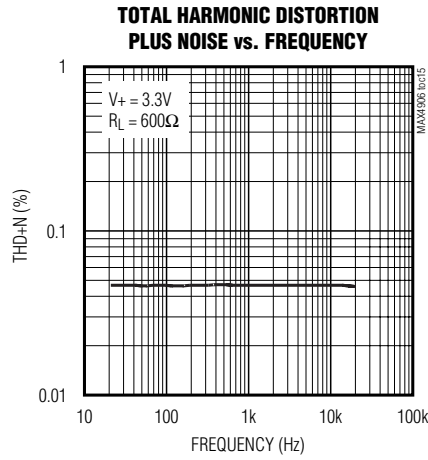
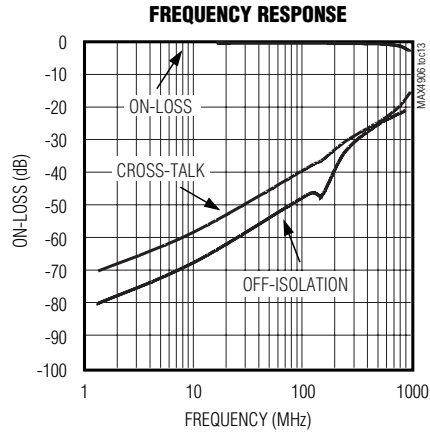
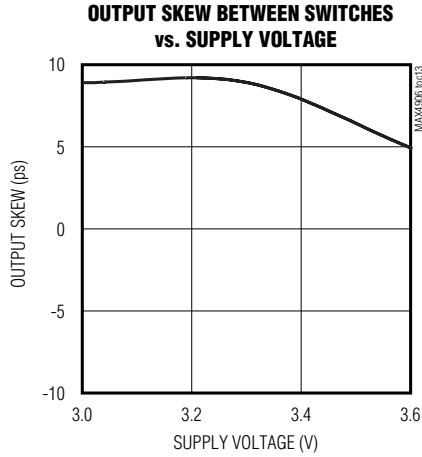

High-/Full-Speed USB 2.0 Switches

Test Circuits/Timing Diagrams (continued)

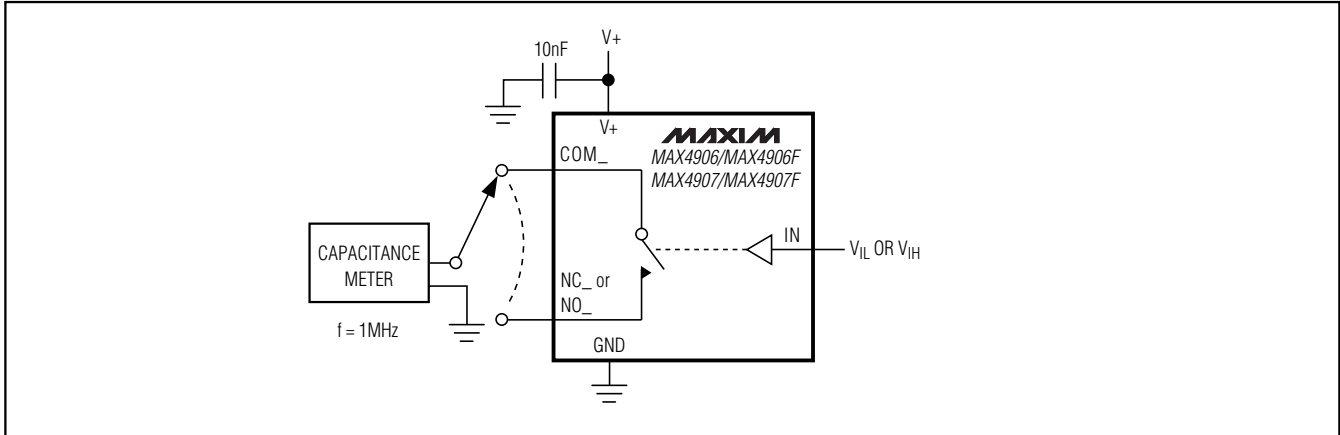

Figure 2. Channel Off/On-Capacitance

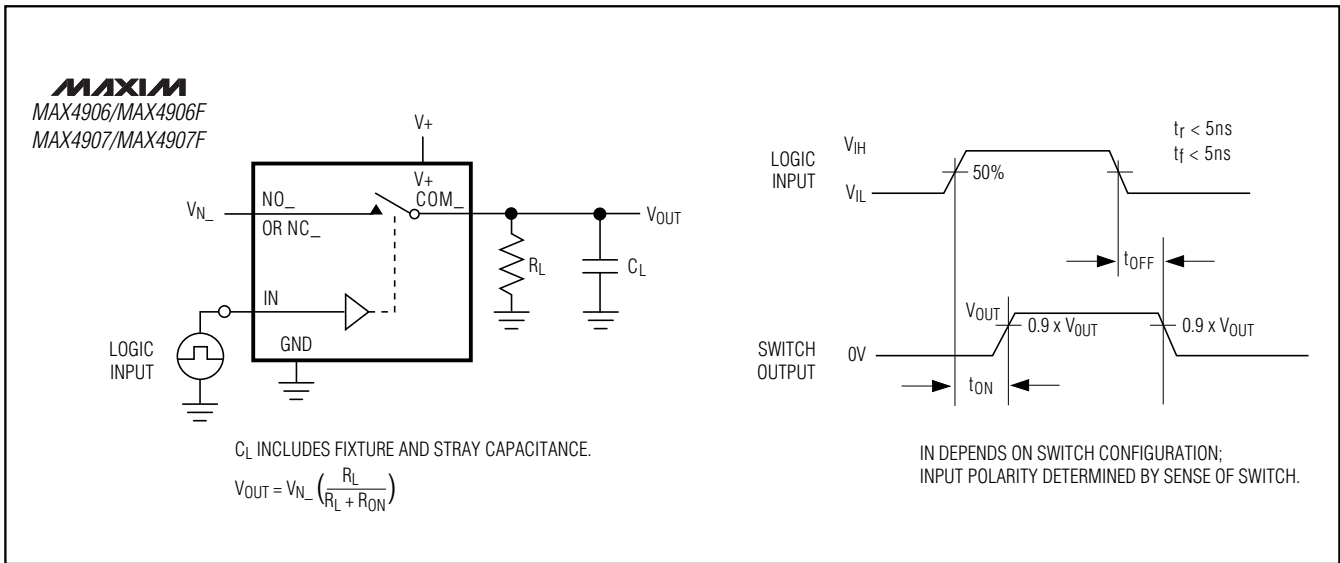

Figure 3. Switching Time

High-/Full-Speed USB 2.0 Switches

Test Circuits/Timing Diagrams (continued)

MAX4906/MAX4906F/MAX4907/MAX4907F

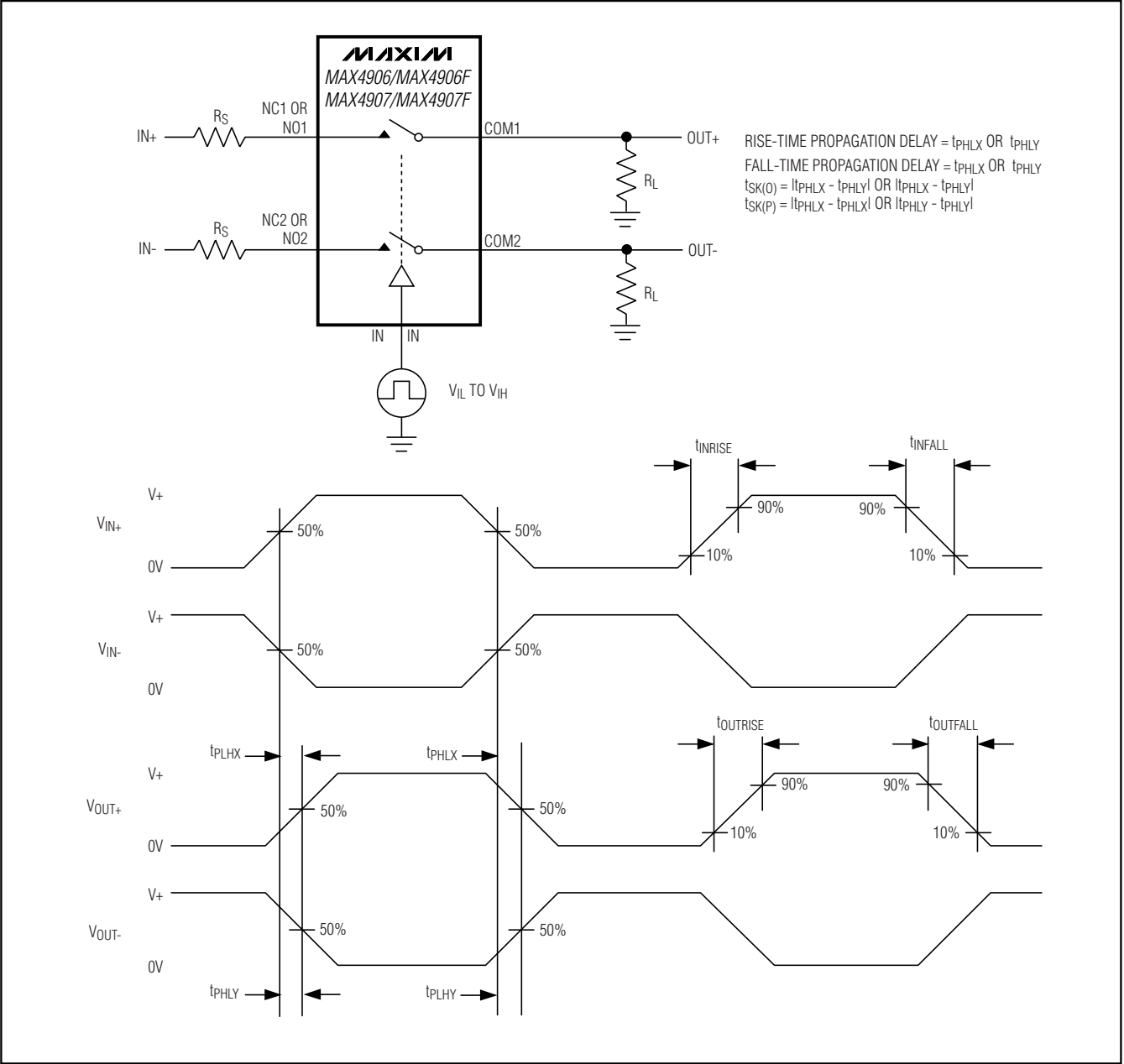

Figure 4. Output Signal Skew, Rise/Fall Time, Propagation Delay

High-/Full-Speed USB 2.0 Switches

Test Circuits/Timing Diagrams (continued)

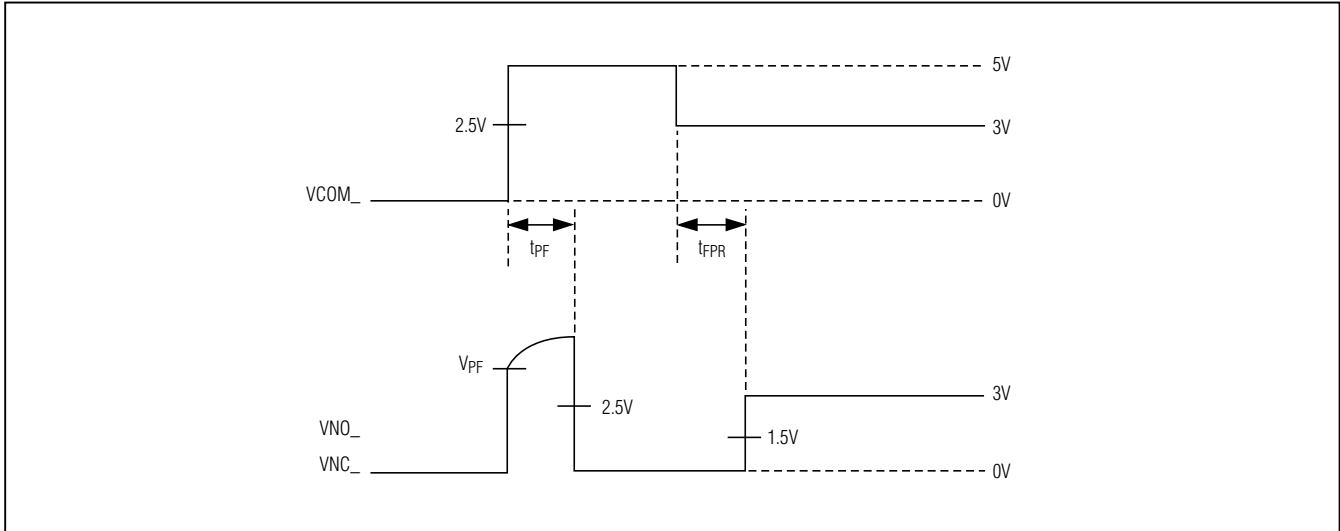

Figure 5. MAX4906F/MAX4907F Fault-Protection Response/Recovery Time

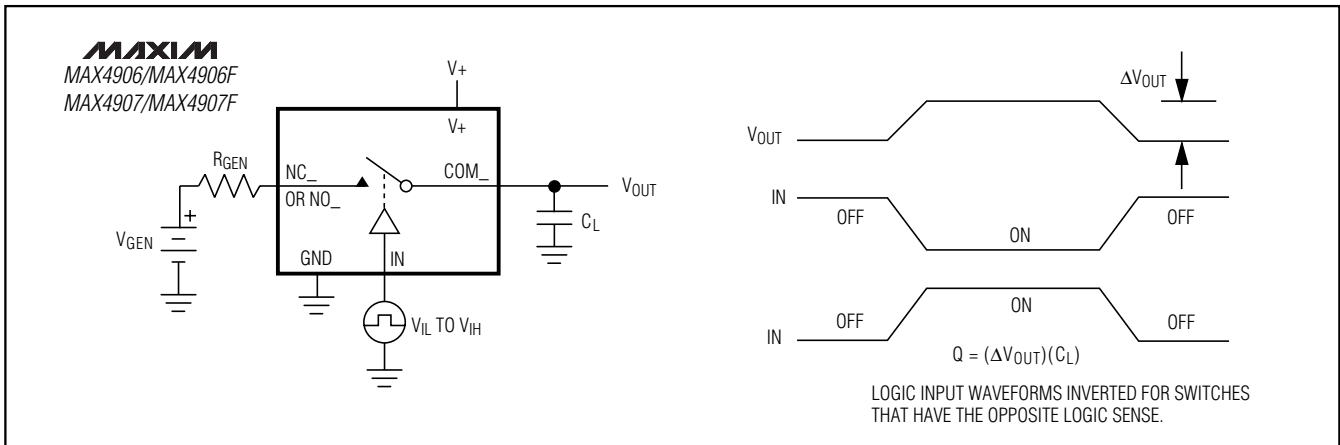

Figure 6. Charge Injection

Detailed Description

The MAX4906/MAX4906F/MAX4907/MAX4907F analog switches are targeted for USB 2.0 high-speed (480Mbps) switching applications. These devices still meet USB low- and full-speed requirements and are suitable for 10/100 Ethernet switching. The MAX4906/MAX4906F feature two SPDT switches, while the MAX4907/MAX4907F feature two SPST switches. The MAX4907/MAX4907F switch configurations have a low 7Ω (max) on-resistance and 7pF (max) on-capacitance.

The MAX4906/MAX4906F/MAX4907/MAX4907F are fully specified to operate from a single +3.0V to +3.6V supply and are available with +5.5V fault protection (MAX4906F/MAX4907F). When operating from a +3.0V to +3.6V supply, the low threshold of these devices permits them to be used with logic levels as low as 1.4V. The MAX4906/MAX4906F/MAX4907/MAX4907F are based on a charge-pump-assisted n-channel architecture and thus operate at 300μA (max) quiescent current. These devices all feature a shutdown input to reduce the quiescent current to less than 2μA (max).

High-/Full-Speed USB 2.0 Switches

Functional Diagram/Truth Table

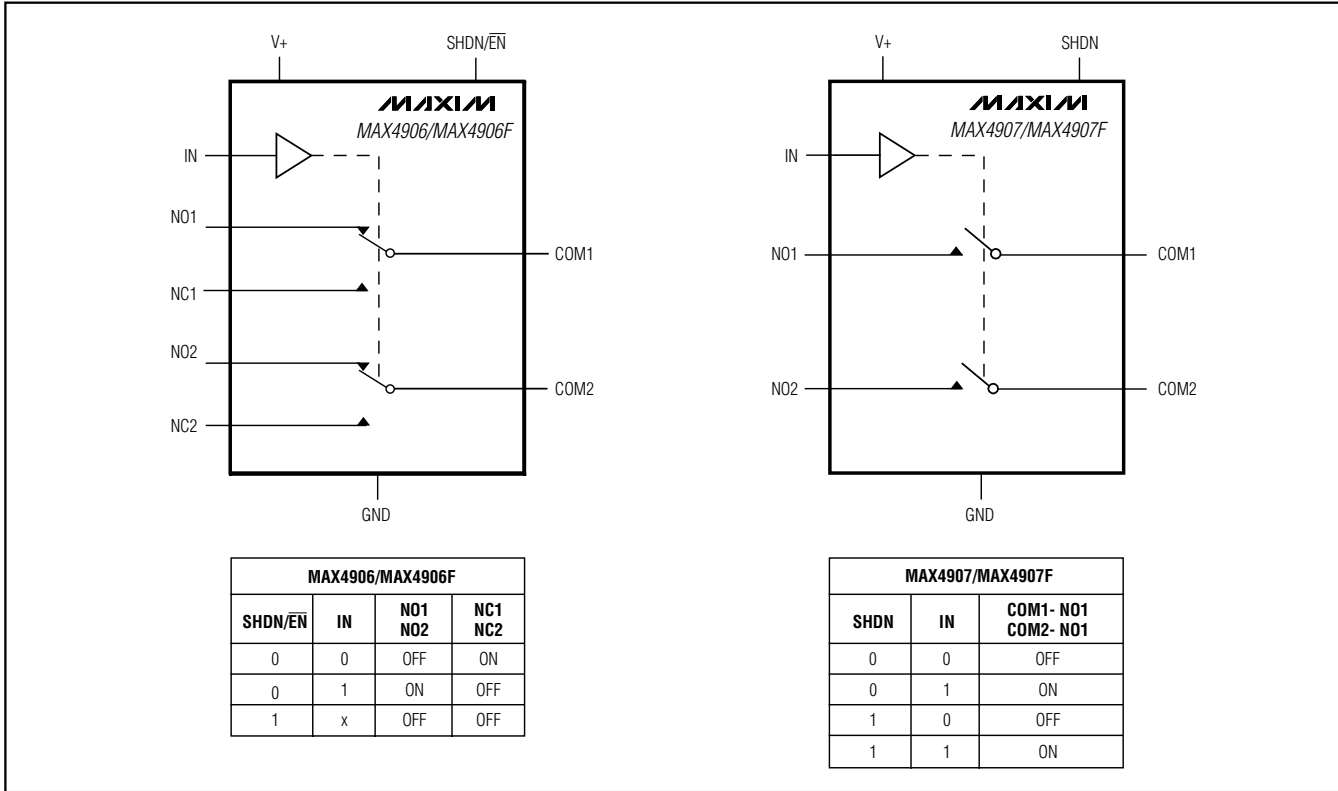

Digital Control Input

The MAX4906/MAX4906F/MAX4907/MAX4907F provide a single-digit control logic input, IN. IN controls the position of the switches as shown in the *Functional Diagram/Truth Table*. Driving IN rail-to-rail minimizes power consumption. With a +3.0V to +3.6V supply voltage range, these devices are +1.4V logic compatible.

Analog Signal Levels

The on-resistance of the MAX4906/MAX4906F/MAX4907/MAX4907F is very low and stable as the analog input signals are swept from ground to V+ (see the *Typical Operating Characteristics*). These switches are bidirectional, allowing NO_, NC_, and COM_ to be configured as either inputs or outputs.

Overvoltage Fault Protection

The MAX4906F and MAX4907F feature +5.5V fault protection to COM1 and COM2. Fault protection prevents these switches from being damaged due to shorts to the USB bus voltage rail.

Shutdown Mode

The MAX4906/MAX4906F feature a shutdown mode that reduces the quiescent current supply to less than 2μA. Drive SHDN/EN high to place the devices in high-impedance mode. When SHDN/EN is driven low, the devices are normal in operation.

The MAX4907/MAX4907F feature a SHDN input that reduces the quiescent current supply to less than 2μA. Drive SHDN high to place the devices in low current mode. The devices can be used in low current mode, but with a reduced analog voltage range of $0 < V_{ANALOG} < 1.5V$ and reduced performance. When SHDN is driven low, the MAX4907/MAX4907F are in normal operation.

Applications Information

USB Switching

The MAX4906/MAX4906F/MAX4907/MAX4907F analog switches are fully compliant with the USB 2.0 specification. The low on-resistance and low on-capacitance of these switches make them ideal for high-performance switching applications. The MAX4906/MAX4906F are

MAX4906/MAX4906F/MAX4907/MAX4907F

High-/Full-Speed USB 2.0 Switches

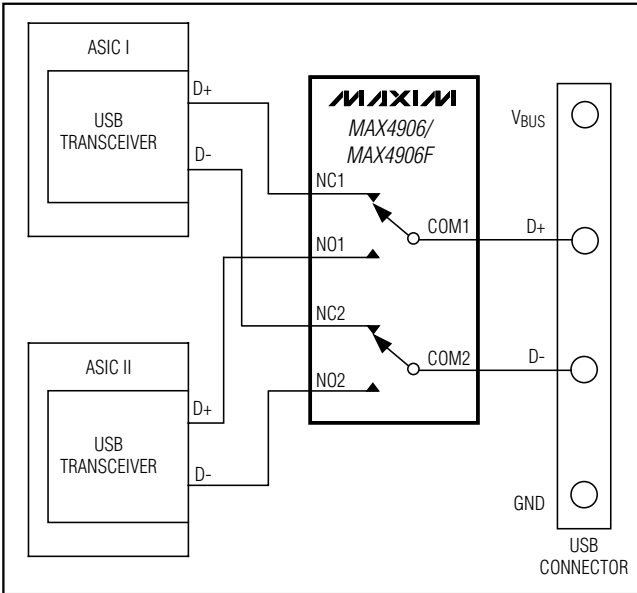

Figure 7. MAX4906/MAX4906F USB Data Routing

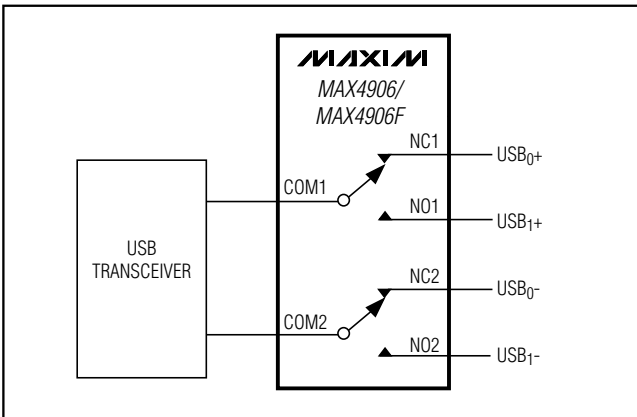

Figure 8. MAX4906/MAX4906F Switching Between Multiple USB Hosts

ideal for routing USB data lines (see Figure 7) and for applications that require switching between multiple USB hosts (see Figure 8). The MAX4907/MAX4907F can be used in applications that require different data types to share the same pins (see Figure 9); however, the shared device must be capable of going into the tri-state mode. The MAX4906F/MAX4907F also feature +5.5V fault protection to guard systems against shorts to the USB bus voltage. The fault-protected versions are recommended for all USB applications.

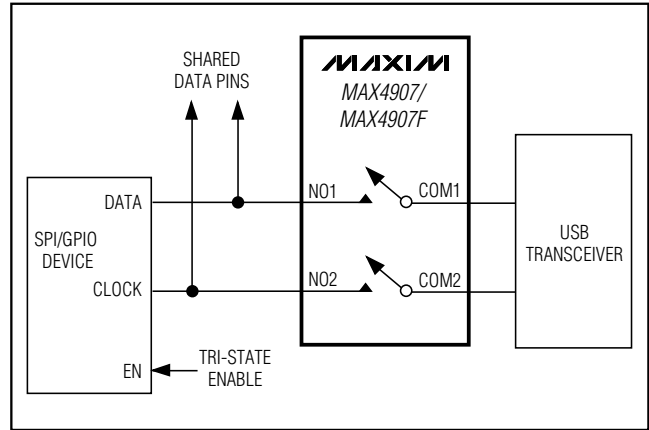

Figure 9. MAX4907/MAX4907F USB/SPI/GPIO Switch

Ethernet Switching

The wide bandwidth of the MAX4906/MAX4906F/MAX4907/MAX4907F meets the needs of 10/100 Ethernet switching. These devices switch the signals from two interface transformers and connect the signals to a single 10/100 Base-T Ethernet PHY, simplifying docking station design and reducing manufacturing costs.

Power-Supply Sequencing

Caution: Do not exceed the absolute maximum ratings because stresses beyond the listed ratings may cause permanent damage to the device.

Proper power-supply sequencing is recommended for all CMOS devices. Always apply V+ before applying analog signals, especially if the analog signal is not current limited.

Layout

High-speed switches require proper layout and design procedures for optimum performance. Keep design-controlled-impedance PC board traces as short as possible. Ensure that bypass capacitors are as close to the device as possible. Use large ground planes where possible.

High-/Full-Speed USB 2.0 Switches

Pin Configurations (continued)

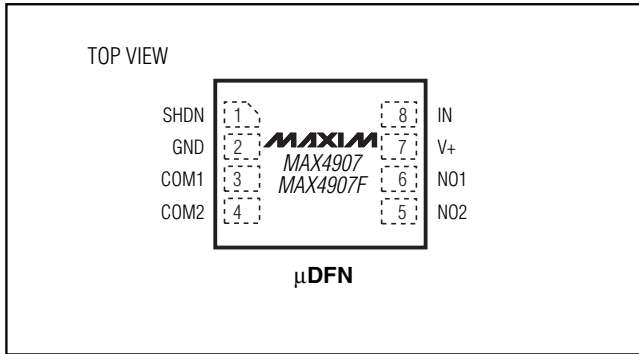

Selector Guide

PART	CONFIGURATION	FAULT PROTECTION	TOP MARK
MAX4906ELB	Dual SPDT	NO	AAB
MAX4906FELB	Dual SPDT	YES	AAA
MAX4907ELA	Dual SPST	NO	AAE
MAX4907FELA	Dual SPST	YES	AAD

Chip Information

PROCESS: BiCMOS

Revision History

Pages changed at Rev 2: 1, 2, 3, 7, 11, 14

MAX4906/MAX4606F/MAX4907/MAX4907F

SITE
SEARCHPART NO.
SEARCH

WHAT'S NEW

PRODUCTS

SOLUTIONS

DESIGN

APPNOTES

SUPPORT

BUY

COMPANY

MEMBERS

Maxim > Products > Analog Switches and Multiplexers

MAX4906, MAX4906F, MAX4907, MAX4907F

High-/Full-Speed USB 2.0 Switches

Designed for Portable Low-Power Applications that Require a Switching Function for One or More USB 2.0 Differential Pairs

QuickView

Technical Documents

Ordering Info

More Information

All

Ordering Information

Notes:

1. Other options and links for purchasing parts are listed at: <http://www.maxim-ic.com/sales>.
2. **Didn't Find What You Need?** Ask our applications engineers. Expert assistance in finding parts, usually within one business day.
3. Part number suffixes: T or T&R = tape and reel; + = RoHS/lead-free; # = RoHS/lead-exempt. More: See [Full Data Sheet](#) or [Part Naming Conventions](#).
4. * Some packages have variations, listed on the drawing. "PkgCode/Variation" tells which variation the product uses.

Devices: 1-30 of 30

MAX4906	Free Sample	Buy	Package: TYPE PINS FOOTPRINT DRAWING CODE/VAR *	Temp	RoHS/Lead-Free? Materials Analysis
MAX4906ELB+T			MicroDFN;10 pin;4 mm Dwg: 21-0164A (PDF) Use pkgcode/variation: L1022+1*	-40C to +85C	RoHS/Lead-Free: Lead Free Materials Analysis
MAX4906ELB+			MicroDFN;10 pin;4 mm Dwg: 21-0164A (PDF) Use pkgcode/variation: L1022+1*	-40C to +85C	RoHS/Lead-Free: Lead Free Materials Analysis
MAX4906ELB			MicroDFN;10 pin;4 mm Dwg: 21-0164A (PDF) Use pkgcode/variation: L1022-1*	-40C to +85C	RoHS/Lead-Free: See data sheet Materials Analysis
MAX4906ELB-T			MicroDFN;10 pin;4 mm Dwg: 21-0164A (PDF) Use pkgcode/variation: L1022-1*	-40C to +85C	RoHS/Lead-Free: See data sheet Materials Analysis
MAX4906ETB+			THIN QFN (Dual);10 pin;10 mm Dwg: 21-0137I (PDF) Use pkgcode/variation: T1033+1*	-40C to +85C	RoHS/Lead-Free: Lead Free Materials Analysis
MAX4906ETB+T			THIN QFN (Dual);10 pin;10 mm Dwg: 21-0137I (PDF) Use pkgcode/variation: T1033+1*	-40C to +85C	RoHS/Lead-Free: Lead Free Materials Analysis
MAX4906ETB			THIN QFN (Dual);10 pin;10 mm Dwg: 21-0137I (PDF) Use pkgcode/variation: T1033-1*	-40C to +85C	RoHS/Lead-Free: See data sheet Materials Analysis
MAX4906ETB-T			THIN QFN (Dual);10 pin;10 mm Dwg: 21-0137I (PDF) Use pkgcode/variation: T1033-1*	-40C to +85C	RoHS/Lead-Free: See data sheet Materials Analysis
MAX4906F	Free Sample	Buy	Package: TYPE PINS FOOTPRINT DRAWING CODE/VAR *	Temp	RoHS/Lead-Free? Materials Analysis
MAX4906FELB+			MicroDFN;10 pin;4 mm Dwg: 21-0164A (PDF) Use pkgcode/variation: L1022+1*	-40C to +85C	RoHS/Lead-Free: Lead Free Materials Analysis
MAX4906FELB			MicroDFN;10 pin;4 mm Dwg: 21-0164A (PDF) Use pkgcode/variation: L1022-1*	-40C to +85C	RoHS/Lead-Free: No Materials Analysis
MAX4906FELB+T			MicroDFN;10 pin;4 mm Dwg: 21-0164A (PDF) Use pkgcode/variation: L1022+1*	-40C to +85C	RoHS/Lead-Free: Lead Free Materials Analysis

MAX4906FELB-T			MicroDFN;10 pin;4 mm Dwg: 21-0164A (PDF) Use pkgcode/variation: L1022-1*	-40C to +85C	RoHS/Lead-Free: No Materials Analysis
MAX4906FETB+T			THIN QFN (Dual);10 pin;10 mm Dwg: 21-0137I (PDF) Use pkgcode/variation: T1033+1*	-40C to +85C	RoHS/Lead-Free: Lead Free Materials Analysis
MAX4906FETB+			THIN QFN (Dual);10 pin;10 mm Dwg: 21-0137I (PDF) Use pkgcode/variation: T1033+1*	-40C to +85C	RoHS/Lead-Free: Lead Free Materials Analysis
MAX4907	Free Sample	Buy	Package: TYPE PINS FOOTPRINT DRAWING CODE/VAR *	Temp	RoHS/Lead-Free? Materials Analysis
MAX4907ELA+			MicroDFN;8 pin;4 mm Dwg: 21-0164A (PDF) Use pkgcode/variation: L822+1*	-40C to +85C	RoHS/Lead-Free: Lead Free Materials Analysis
MAX4907ELA+T			MicroDFN;8 pin;4 mm Dwg: 21-0164A (PDF) Use pkgcode/variation: L822+1*	-40C to +85C	RoHS/Lead-Free: Lead Free Materials Analysis
MAX4907ELA			MicroDFN;8 pin;4 mm Dwg: 21-0164A (PDF) Use pkgcode/variation: L822-1*	-40C to +85C	RoHS/Lead-Free: No Materials Analysis
MAX4907ELA-T			MicroDFN;8 pin;4 mm Dwg: 21-0164A (PDF) Use pkgcode/variation: L822-1*	-40C to +85C	RoHS/Lead-Free: No Materials Analysis
MAX4907ETA+T			THIN QFN (Dual);8 pin;10 mm Dwg: 21-0137I (PDF) Use pkgcode/variation: T833+3*	-40C to +85C	RoHS/Lead-Free: Lead Free Materials Analysis
MAX4907ETA+			THIN QFN (Dual);8 pin;10 mm Dwg: 21-0137I (PDF) Use pkgcode/variation: T833+3*	-40C to +85C	RoHS/Lead-Free: Lead Free Materials Analysis
MAX4907ETA			THIN QFN (Dual);8 pin;10 mm Dwg: 21-0137I (PDF) Use pkgcode/variation: T833-3*	-40C to +85C	RoHS/Lead-Free: No Materials Analysis
MAX4907ETA-T			THIN QFN (Dual);8 pin;10 mm Dwg: 21-0137I (PDF) Use pkgcode/variation: T833-3*	-40C to +85C	RoHS/Lead-Free: No Materials Analysis
MAX4907F	Free Sample	Buy	Package: TYPE PINS FOOTPRINT DRAWING CODE/VAR *	Temp	RoHS/Lead-Free? Materials Analysis
MAX4907FELA			MicroDFN;8 pin;4 mm Dwg: 21-0164A (PDF) Use pkgcode/variation: L822-1*	-40C to +85C	RoHS/Lead-Free: No Materials Analysis
MAX4907FELA+T			MicroDFN;8 pin;4 mm Dwg: 21-0164A (PDF) Use pkgcode/variation: L822+1*	-40C to +85C	RoHS/Lead-Free: Lead Free Materials Analysis
MAX4907FELA+			MicroDFN;8 pin;4 mm Dwg: 21-0164A (PDF) Use pkgcode/variation: L822+1*	-40C to +85C	RoHS/Lead-Free: Lead Free Materials Analysis
MAX4907FELA-T			MicroDFN;8 pin;4 mm Dwg: 21-0164A (PDF) Use pkgcode/variation: L822-1*	-40C to +85C	RoHS/Lead-Free: No Materials Analysis
MAX4907FETA+			THIN QFN (Dual);8 pin;10 mm Dwg: 21-0137I (PDF) Use pkgcode/variation: T833+3*	-40C to +85C	RoHS/Lead-Free: Lead Free Materials Analysis
MAX4907FETA+T			THIN QFN (Dual);8 pin;10 mm Dwg: 21-0137I (PDF) Use pkgcode/variation: T833+3*	-40C to +85C	RoHS/Lead-Free: Lead Free Materials Analysis
MAX4907FETA			THIN QFN (Dual);8 pin;10 mm Dwg: 21-0137I (PDF) Use pkgcode/variation: T833-3*	-40C to +85C	RoHS/Lead-Free: No Materials Analysis
MAX4907FETA-T			THIN QFN (Dual);8 pin;10 mm Dwg: 21-0137I (PDF) Use pkgcode/variation: T833-3*	-40C to +85C	RoHS/Lead-Free: No Materials Analysis

Didn't Find What You Need?

- [Next Day Product Selection Assistance from Applications Engineers](#)
- [Parametric Search](#)
- [Applications Help](#)

QuickView

[Description](#)
[Key Features](#)
[Applications/Uses](#)
[Key Specifications](#)
[Diagram](#)

Technical Documents

[Data Sheet](#)
[Application Notes](#)
[Design Guides](#)
[Engineering Journals](#)
[Reliability Reports](#)
[Software/Models](#)
[Evaluation Kits](#)

Ordering Info

[Price and Availability](#)
[Samples](#)
[Buy Online](#)
[Package Information](#)
[Lead-Free Information](#)

More Information

[Related Products](#)
[Notes and Comments](#)
[Evaluation Kits](#)

Document Ref.: 19-3797; Rev 2; 2007-03-23
This page last modified: 2007-06-26

[CONTACT US: SEND US AN EMAIL](#)