



FEATURES

- Glass passivated device
- Ideal for surface mounted applications
- Low leakage current
- Metallurgically bonded construction
- High temperature soldering:
/10 seconds at terminals

Mechanical Data

Case: JEDEC SOD-123FL, molded plastic over passivated chip

Terminals: Solder Plated, solderable per MIL-STD-750, Method 2026

Polarity: Color band denotes cathode end

Weight: 0.003 ounces, 0.01 gram

Mounting position: Any

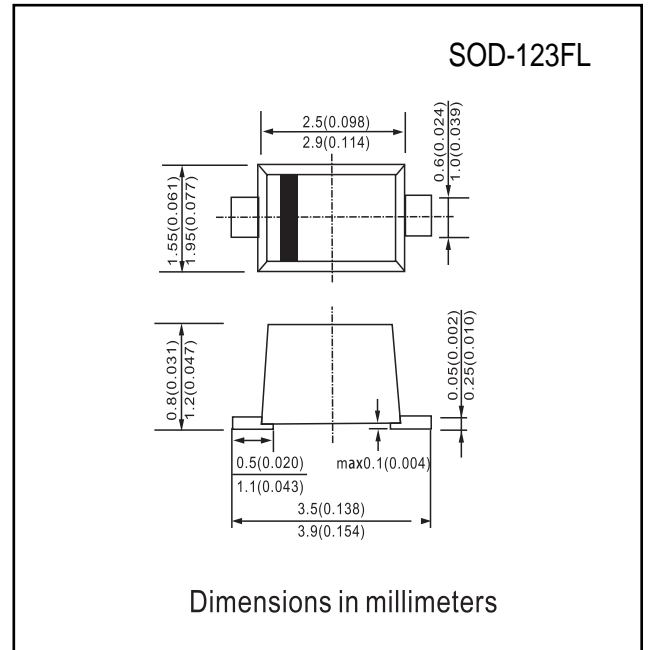

MAXIMUM RATINGS AND ELECTRICAL CHARACTERISTICS

Ratings at 25 ambient temperature unless otherwise specified.
Single phase, half wave, 60Hz, resistive or inductive load. For capacitive load, derate current by 20%.

		SOD 1E1	SOD 1E2	SOD 1E3	SOD 1E4	SOD 1E5	SOD 1E6	SOD 1E7	SOD 1E8	UNITS
Device marking code		E1	E2	E3	E4	E5	E6	E7	E8	
Maximum recurrent peak reverse voltage	V_{RRM}	50	100	150	200	300	400	500	600	V
Maximum RMS voltage	V_{RMS}	35	70	105	140	210	280	350	420	V
Maximum DC blocking voltage	V_{DC}	50	100	150	200	300	400	500	600	V
Maximum average forward rectified current $T_A=65$	$I_{(AV)}$	1.0								A
Peak forward surge current 8.3ms single half-sine-wave superimposed on rated load $T_L=25$	I_{FSM}	25								A
Maximum instantaneous (NOTE 1) forward voltage at 1.0A	V_F	0.95			1.25		1.7			V
Maximum DC reverse current @ $T_A=25$ at rated DC blocking voltage @ $T_A=125$	I_R	5.0				150				μA
Maximum reverse recovery time (NOTE 2)	t_{rr}	35								ns
Operating temperature range	T_j	- 55 --- + 150								
Storage temperature range	T_{STG}	- 55 --- + 150								

NOTES: 1. Pulse test: 300ms pulse width, 1% duty cycle.

2. Measured with $I_F=0.5A$, $I_R=1A$, $I_{rr}=0.25A$.



RATINGS AND CHARACTERISTIC CURVES SOD1E1 THRU SOD1E8

FIG. 1 - TYPICAL FORWARD CURRENT DERATING CURVE

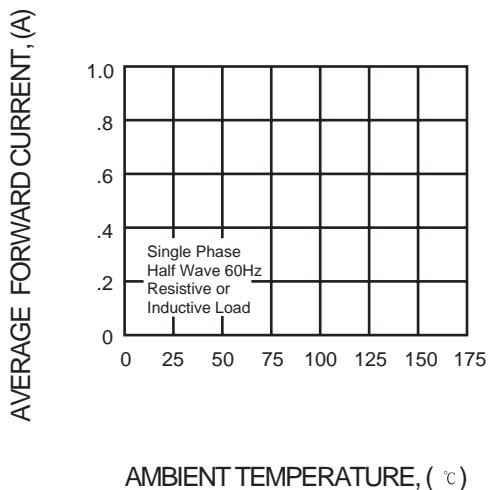

FIG. 2 - MAXIMUM NON-REPETITIVE FORWARD SURGE CURRENT

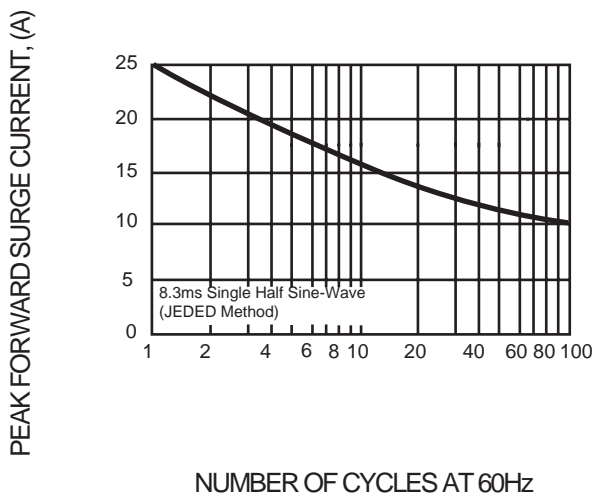

FIG. 3 - TYPICAL INSTANTANEOUS FORWARD CHARACTERISTICS



FIG. 4 - TYPICAL REVERSE CHARACTERISTICS

