

Multi-mode (WCDMA B5 / CDMA BC0 / HSPA+ / LTE) 3x3mm PA Module

Functional Block Diagram

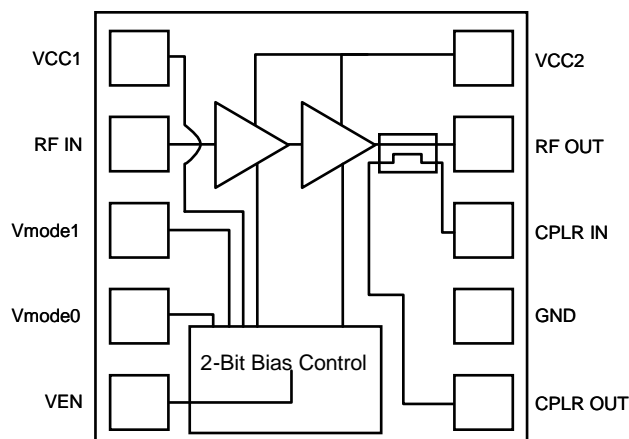

Product Description

The TQM716015 is fully matched Power Amplifier Module designed for use in CDMA (BC0), WCDMA (Bands 5&6) and LTE handsets. Its compact 3x3mm package including a coupler and built-in voltage regulator makes it ideal for today's extremely small data enabled phones. Its RF performance meets the stringent linearity requirements for multi-mode operation.

The TQM716015 is designed on TriQuint's GaAs BiHEMT technology with CuFlip® assembly offering state of the art reliability, temperature stability and ruggedness. The 3-Gain state PA die operates in LPM, MPM and HPM to maximize talk time over the entire range of operating conditions. To simplify the cost/time of calibration while in production the TQM716015 can be used in 1-bit operation; either LPM/HPM with only 3.5mA of IcQ up to +13dBm in LPM, or MPM/HPM with 11mA of IcQ up to +17dBm in MPM.

Electrical Specifications

| Parameter | Typ | Units |
|--------------------------------------|------|--------|
| Frequency | 836 | MHz |
| WCDMA mode maximum Pout ¹ | 28.3 | dBm |
| LPM Quiescent Current | 3.5 | mA |
| ACLR5 | -41 | dBc |
| ACLR10 | -56 | dBc |
| Power Supply Current @ 28.3dBm | 510 | mA |
| Rx Band Noise | -132 | dBm/Hz |

Note 1: Test Conditions WCDMA REL99 Test Mode: V_{CC}=3.4VDC, V_{EN}=HIGH, T_c=25°C

Features

- GaAs BiHEMT / CuFlip® PA Technology
- Typical Quiescent Current values:
LPM: 3.5 mA
MPM: 11 mA
HPM: 80 mA
- Excellent Linearity in all modes
- Excellent Phase Discontinuity
- Integrated high performance coupler
- Built-in voltage regulator functionality eliminating any external switch circuitry
- Small 10-pin, 3x3mm module
- Lead-free 260°C / RoHS / Halogen-free
- Full ESD protection

Applications

- WCDMA B5 Applications
- CDMA2000 Cellular (BC0) Applications
- HSDPA/HSUPA/HSPA+ Applications
- LTE-Compatible Applications

Package Style

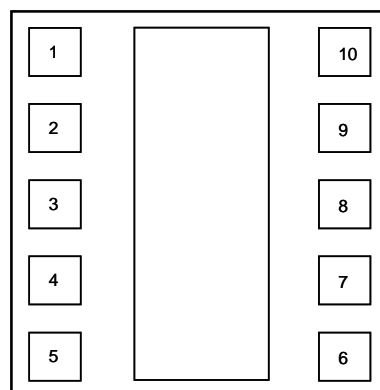

10-Pin Laminate Module
Top View (through package)

Data Sheet

For additional information and latest specifications, see our website: www.triquint.com
Revision N, August 08, 2012

