

CAD GENERATED DRAWING - NO PENCIL CHANGES ALLOWED

% OF RATED CURRENT	OPENING TIME	
	MIN	MAX
110%	14,400 SEC.	-
200%	5 SEC.	100 SEC.
350%	0.2 SEC.	7 SEC.
600%	0.04 SEC.	1 SEC.

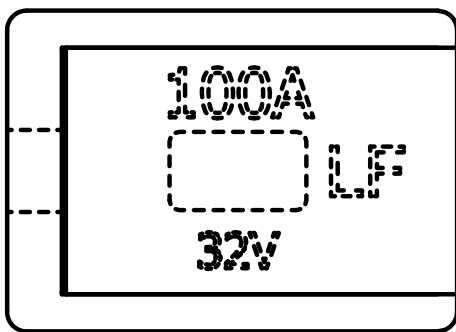

PART NUMBER	CURRENT RATING (A)	BODY COLOR
0294030.MXJ	30	PINK
0294040.MXJ	40	GREEN
0294050.MXJ	50	RED
0294060.MXJ	60	YELLOW
0294070.MXJ	70	BROWN
0294080.MXJ	80	BLACK
0294100.MXJ	100	BLUE
0294120.MXJ	120	WHITE

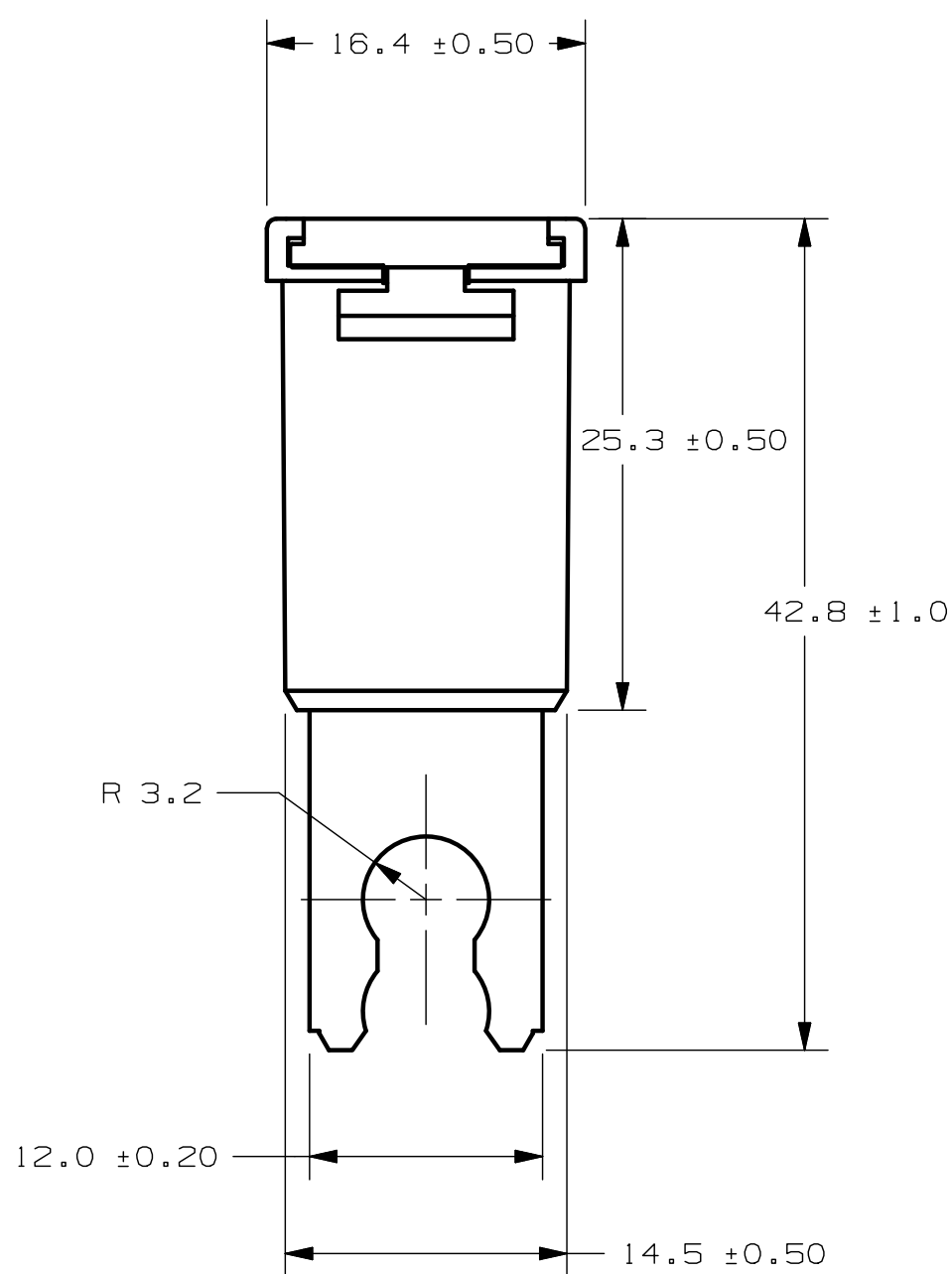
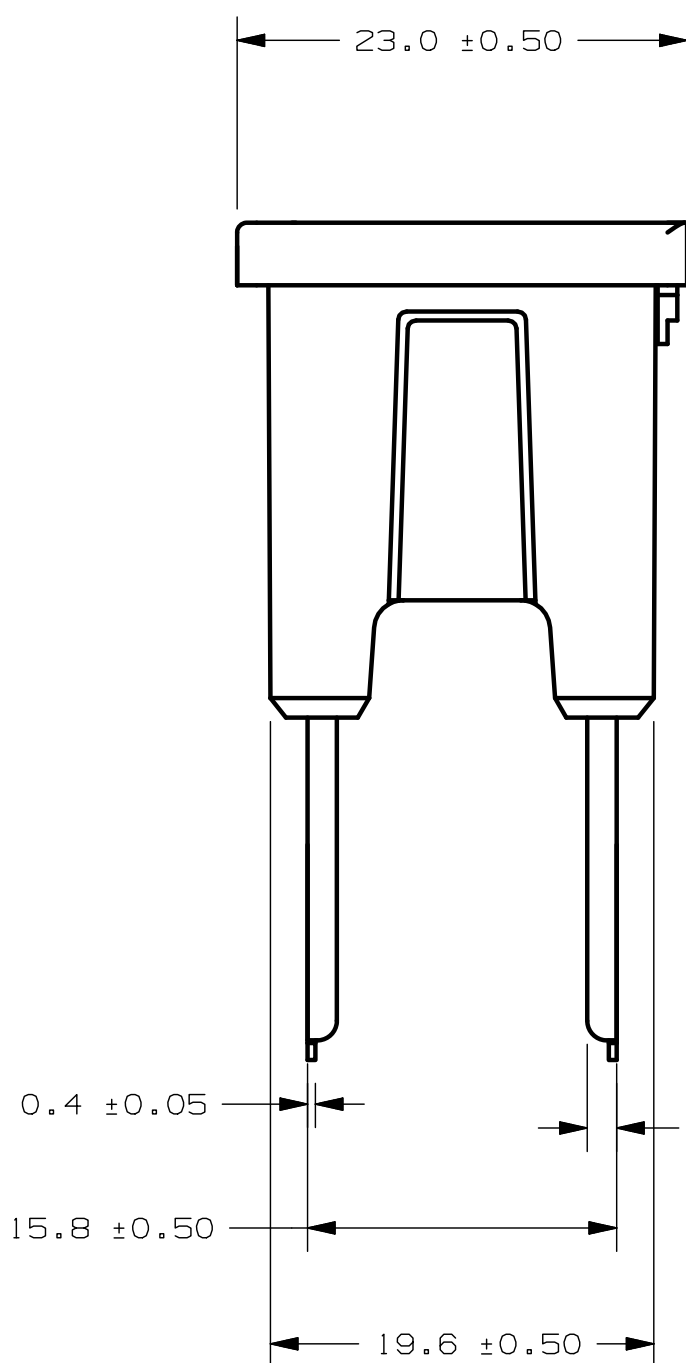

METRIC

\odot	DENOTES CRITICAL CHARACTERISTICS.
CPK	DENOTES CPK DIMENSIONS, -MINIMUM CPK VALUE
(ST)	DENOTES A CHARACTERISTIC THAT PROVIDES AN INDICATION OF PROCESS PERFORMANCE. PROCEDURE FOR MEASUREMENT AND TRACKING TO BE DEFINED IN LITTELFUSE INSPECTION INSTRUCTIONS
CP	DENOTES CP DIMENSIONS, -MINIMUM CP VALUE MUST BE WITHIN THE DIMENSIONAL LIMITATIONS SHOWN ON DRAWING AND INITIALLY LOCATED TO ALLOW FOR MAXIMUM TOOL LIFE

COPIES TO		MATERIAL SPEC	
LTR	DATE	REVISION	CHK
A	08/14/09	000762ER-RELEASE	GMB
1	9	18	
2	10	19	
3	12	20	
4	13	21	
5	14	23	
6	15	33	
7	16	43	
8	17	53	

DATE	08/14/09	SCALE	2:1
DRW	GMB	SUPER DR	
CHK		FINISH GOOD WT	
APPD		GRAMS/PIECE	

TOLERANCE UNLESS OTHERWISE SPECIFIED	ONE PLACE DEC +/- .4
THREE PLACE DEC +/- .100	ANGULAR +/- 1°

TITLE	BOLT DOWN HIGH CURRENT CARTRIDGE FUSE
REVISION	A
DRAWG. NO.	OL-0294000.MXJ

3RD ANGLE PROJECTION	
	DES PLAINES, ILLINOIS 60016