

## Dual Full-Bridge DMOS PWM Motor Driver

### Features and Benefits

- Low  $R_{DS(on)}$  outputs
- Overcurrent protection (OCP)
  - Motor short protection
  - Motor lead short to ground protection
  - Motor lead short to battery protection
- Low Power Standby mode
- Adjustable PWM current limit
- Synchronous rectification
- Internal undervoltage lockout (UVLO)
- Crossover-current protection

### Package: 16-pin TSSOP with exposed thermal pad (suffix LP)

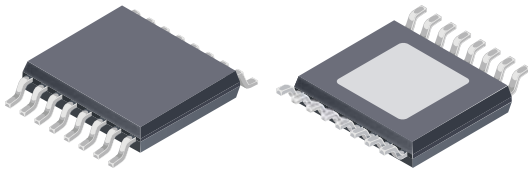

Not to scale

### Description

Designed for pulse width modulated (PWM) control of two DC motors, the A4954 is capable of peak output currents to  $\pm 2$  A and operating voltages to 40 V.

Input terminals are provided for use in controlling the speed and direction of a DC motor with externally applied PWM control signals. Internal synchronous rectification control circuitry is provided to lower power dissipation during PWM operation.

Internal circuit protection includes overcurrent protection, motor lead short to ground or supply, thermal shutdown with hysteresis, undervoltage monitoring of  $V_{BB}$ , and crossover-current protection.

The A4954 is provided in a low-profile 16-pin TSSOP package with exposed thermal pad (suffix LP) that is lead (Pb) free, with 100% matte tin leadframe plating.

### Functional Block Diagram

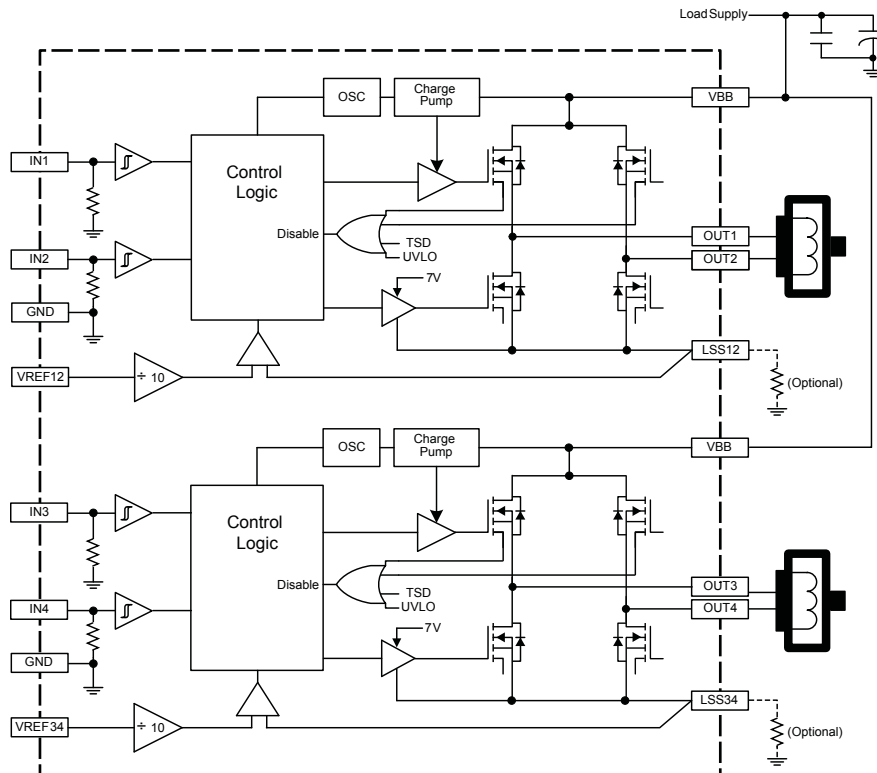

## Selection Guide

Part Number	Packing
A4954ELPTR-T	4000 pieces per 13-in. reel
A4954ELP-T	96 pieces per tube



## Absolute Maximum Ratings

Characteristic	Symbol	Notes	Rating	Unit
Load Supply Voltage	$V_{BB}$		40	V
Logic Input Voltage Range	$V_{IN}$		-0.3 to 6	V
$V_{REF}$ Input Voltage Range	$V_{REF}$		-0.3 to 6	V
Sense Voltage (LSSx pin)	$V_S$		-0.5 to 0.5	V
Motor Outputs Voltage	$V_{OUT}$		-2 to 42	V
Output Current	$I_{OUT}$	Duty cycle = 100%	2	A
Transient Output Current	$i_{OUT}$	$T_W < 500$ ns	5	A
Operating Temperature Range	$T_A$	Temperature Range E	-40 to 85	°C
Maximum Junction Temperature	$T_J(\text{max})$		150	°C
Storage Temperature Range	$T_{stg}$		-55 to 150	°C

**Thermal Characteristics** may require derating at maximum conditions, see application information

Characteristic	Symbol	Test Conditions*	Value	Unit
Package Thermal Resistance	$R_{\theta JA}$	On 2-layer PCB with 3.8 in <sup>2</sup> exposed 2-oz. copper each side	43	°C/W
		On 4-layer PCB based on JEDEC standard	34	°C/W

\*Additional thermal information available on the Allegro website.

## Terminal List Table

Number	Name	Function
1	GND	Ground
2	VREF34	Analog input for bridge 3-4
3	IN3	Logic input 3
4	IN4	Logic input 4
5	IN2	Logic input 2
6	IN1	Logic input 1
7	VREF12	Analog input for bridge 1-2
8	GND	Ground
9	VBB	Load supply voltage
10	OUT1	DMOS full bridge output 1
11	LSS12	Power return – sense resistor connection for bridge 1-2
12	OUT2	DMOS full bridge output 2
13	OUT3	DMOS full bridge output 3
14	LSS34	Power return – sense resistor connection for bridge 3-4
15	OUT4	DMOS full bridge output 4
16	VBB	Load supply voltage
–	PAD	Exposed pad for enhanced thermal dissipation

## Pin-out Diagram

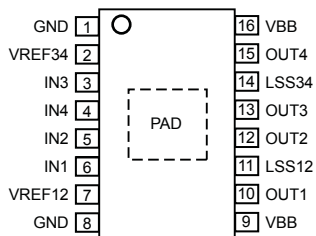

## ELECTRICAL CHARACTERISTICS Valid at $T_J = 25^\circ\text{C}$ , unless otherwise specified

Characteristics	Symbol	Test Conditions	Min.	Typ.	Max.	Unit
<b>General</b>						
Load Supply Voltage Range	$V_{BB}$		8	–	40	V
$R_{DS(on)}$ Sink + Source Total	$R_{DS(on)}$	$I_{OUT} =  1.5\text{ A} , T_J = 25^\circ\text{C}$	–	0.8	1.12	$\Omega$
		$I_{OUT} =  1.5\text{ A} , T_J = 125^\circ\text{C}$	–	1.28	1.8	$\Omega$
Load Supply Current	$I_{BB}$	$f_{PWM} < 30\text{ kHz}$	–	10	–	mA
		Low Power Standby mode	–	–	10	$\mu\text{A}$
Body Diode Forward Voltage	$V_f$	Source diode, $I_f = -1.5\text{ A}$	–	–	1.5	V
		Sink diode, $I_f = 1.5\text{ A}$	–	–	1.5	V
<b>Logic Inputs</b>						
Logic Input Voltage Range	$V_{IN(1)}$		2.0	–	–	V
	$V_{IN(0)}$		–	–	0.8	V
	$V_{IN(STANDBY)}$	Low Power Standby mode	–	–	0.4	V
Logic Input Current	$I_{IN(1)}$	$V_{IN} = 2.0\text{ V}$	–	40	100	$\mu\text{A}$
	$I_{IN(0)}$	$V_{IN} = 0.8\text{ V}$	–	16	40	$\mu\text{A}$
Logic Input Pull-Down Resistance	$R_{LOGIC(PD)}$	$V_{IN} = 0\text{ V} = IN1 = IN2 = IN3 = IN4$	–	50	–	k $\Omega$
Input Hysteresis	$V_{HYS}$		–	250	550	mV
<b>Timing</b>						
Crossover Delay	$t_{COD}$		50	–	500	ns
$V_{REF}$ Input Voltage Range	$V_{REF}$		0	–	5	V
Current Gain	$A_V$	$V_{REF} / I_{SS}, V_{REF} = 5\text{ V}$	9.5	–	10.5	V/V
		$V_{REF} / I_{SS}, V_{REF} = 2.5\text{ V}$	9.0	–	10.0	V/V
		$V_{REF} / I_{SS}, V_{REF} = 1\text{ V}$	8.0	–	10.0	V/V
Blank Time	$t_{BLANK}$		2	3	4	$\mu\text{s}$
Constant Off-time	$t_{off}$		16	25	34	$\mu\text{s}$
Standby Timer	$t_{st}$	$IN1 = IN2 = IN3 = IN4 < V_{IN(STANDBY)}$	–	1	1.5	ms
Power-Up Delay	$t_{pu}$		–	–	30	$\mu\text{s}$
<b>Protection Circuits</b>						
UVLO Enable Threshold	$V_{BBUVLO}$	$V_{BB}$ increasing	7	7.5	7.95	V
UVLO Hysteresis	$V_{BBUVLOhys}$		–	500	–	mV
Thermal Shutdown Temperature	$T_{JTSD}$	Temperature increasing	–	160	–	$^\circ\text{C}$
Thermal Shutdown Hysteresis	$T_{TSDhys}$	Recovery = $T_{JTSD} - T_{TSDhys}$	–	15	–	$^\circ\text{C}$

## Characteristic Performance

### PWM Control Timing Diagram

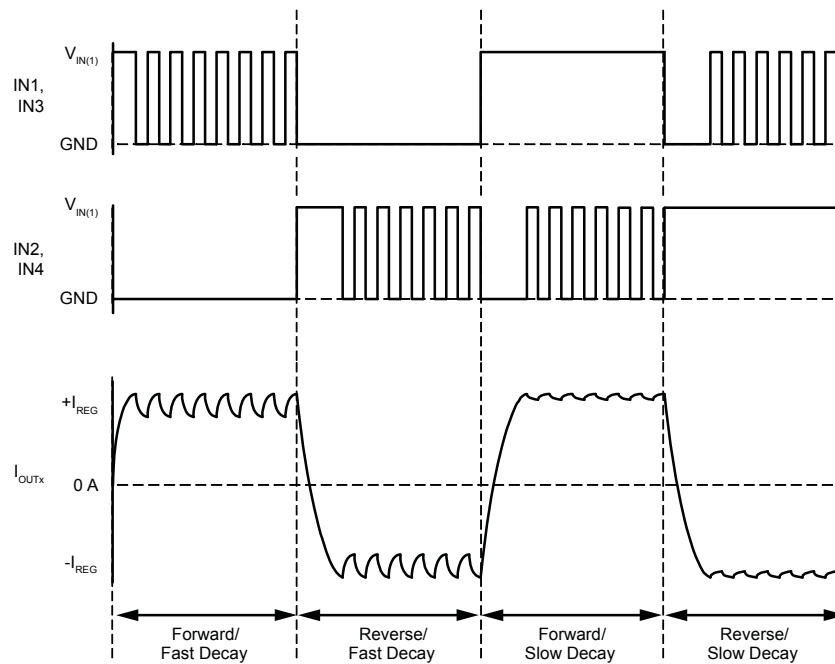

### PWM Control Truth Table

IN1, IN3	IN2, IN4	$10 \times V_S > V_{REF}$	OUT1, OUT3	OUT2, OUT4	Function
0	1	False	L	H	Reverse
1	0	False	H	L	Forward
0	1	True	H/L	L	Chop (mixed decay), reverse
1	0	True	L	H/L	Chop (mixed decay), forward
1	1	False	L	L	Brake (slow decay)
0	0	False	Z	Z	Coast, enters Low Power Standby mode after 1 ms

Note: Z indicates high impedance.

## Functional Description

### Device Operation

The A4954 is designed to operate two DC motors. The output drivers are all low- $R_{DS(on)}$ , N-channel DMOS drivers that feature internal synchronous rectification to reduce power dissipation. The current in each of the two output full bridges is regulated with fixed off-time pulse width modulated (PWM) control circuitry. The IN1-IN2 and IN3-IN4 inputs allow two-wire control for each bridge.

Protection circuitry includes internal thermal shutdown, and protection against shorted loads, or against output shorts to ground or supply. Undervoltage lockout prevents damage by keeping the outputs off until the driver has enough voltage to operate normally.

### Standby Mode

Low Power Standby mode is activated when all four input (INx) pins are low for longer than 1 ms. Low Power Standby mode disables most of the internal circuitry, including the charge pump and the regulator. When the A4954 is coming out of standby mode, the charge pump should be allowed to reach its regulated voltage (a maximum delay of 200  $\mu$ s) before any PWM commands are issued to the device.

### Internal PWM Current Control

Initially, a diagonal pair of source and sink FET outputs are enabled and current flows through the motor winding and the optional external current sense resistor,  $R_{Sx}$ . When the voltage across  $R_{Sx}$  equals the comparator trip value, then the current sense comparator resets the PWM latch. The latch then turns off the sink and source FETs (Mixed Decay mode).

### $V_{REF}$

The maximum value of current limiting is set by the selection of  $R_{Sx}$  and the voltage at the VREFx pin in each channel. The transconductance function is approximated by the maximum value of current limiting,  $I_{TripMAX}$  (A), which is set by:

$$I_{TripMAX} = \frac{V_{REF}}{A_v \times R_s}$$

where  $V_{REF}$  is the input voltage on the VREFx pin (V) and  $R_s$  is the resistance of the sense resistor ( $\Omega$ ) on the corresponding LSSx terminal.

### Overcurrent Protection

A current monitor will protect the IC from damage due to output shorts. If a short is detected, the IC will latch the fault and disable the outputs. Each channel has independent OCP protection. The fault latch can only be cleared by coming out of Low Power Standby mode or by cycling the power to VBB. During OCP events, Absolute Maximum Ratings may be exceeded for a short period of time before the device latches.

### Shutdown

If the die temperature increases to approximately 160°C, the full bridge outputs will be disabled until the internal temperature falls below a hysteresis,  $T_{TSDhys}$ , of 15°C. Internal UVLO is present on VBB to prevent the output drivers from turning-on below the UVLO threshold.

### Braking

The braking function is implemented by driving the device in Slow Decay mode, which is done by applying a logic high to both inputs of both channels, after a bridge-enable Chop command (see PWM Control Truth Table). Because it is possible to drive current in both directions through the DMOS switches, this configuration effectively shorts-out the motor-generated BEMF, as long as the Chop command is asserted. The maximum current can be approximated by  $V_{BEMF} / R_L$ . Care should be taken to ensure that the maximum ratings of the device are not exceeded in worse case braking situations: high speed and high-inertia loads.

Synchronous Rectification

When a PWM off-cycle is triggered by an internal fixed off-time cycle, load current will recirculate. The A4954 synchronous rectification feature turns-on the appropriate DMOSFETs during the current decay, and effectively shorts out the body diodes with the low  $R_{DS(on)}$  driver. This significantly lowers power dissipation. When a zero current level is detected, synchronous rectification is turned off to prevent reversal of the load current.

Mixed Decay Operation

The bridges operate in Mixed Decay mode. Referring to the lower panel of the figure below, as the trip point is reached, the device goes into fast decay mode for 50% of the fixed off-time period. After this fast decay portion the device switches to slow decay mode for the remainder of the off-time. During transitions from fast decay to slow decay, the drivers are forced off for the Crossover Delay,  $t_{COD}$ . This feature is added to prevent shoot-through in the bridge. During this “dead time” portion, synchronous rectification is not active, and the device operates in fast decay and slow decay only.

Mixed Decay Mode Operation

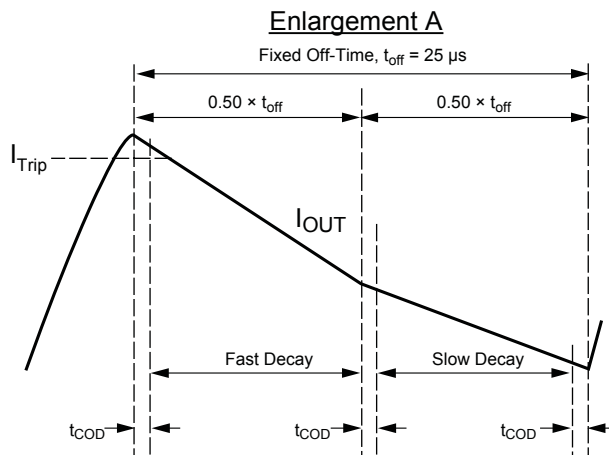
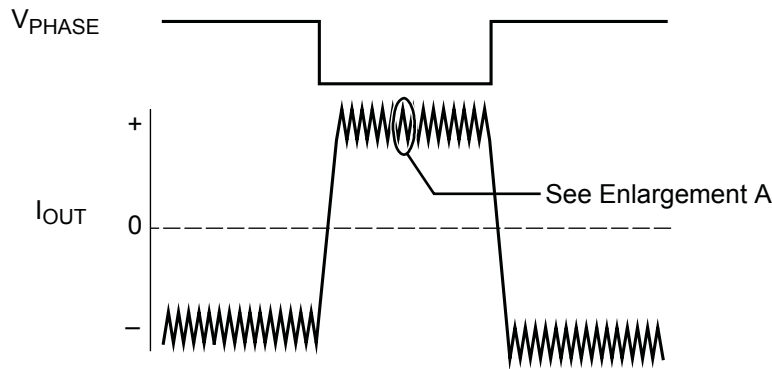

## Application Information

### Sense Pins (LSSx)

In order to use PWM current control, a low-value resistor is placed between the LSSx pin and ground for current sensing purposes. To minimize ground-trace IR drops in sensing the output current level, the current sensing resistor should have an independent ground return to the star ground point. This trace should be as short as possible. For low-value sense resistors, the IR drops in the PCB can be significant, and should be taken into account.

When selecting a value for the sense resistor be sure not to exceed the maximum voltage on the LSSx pin of  $\pm 500$  mV at maximum load. During overcurrent events, this rating may be exceeded for short durations.

### Ground

A star ground should be located as close to the A4954 as possible. The copper ground plane directly under the exposed thermal pad

of the device makes a good location for the star ground point. The exposed pad can be connected to ground for this purpose.

### Layout

The PCB should have a thick ground plane. For optimum electrical and thermal performance, the A4954 must be soldered directly onto the board. On the underside of the A4954 package is an exposed pad, which provides a path for enhanced thermal dissipation. The thermal pad must be soldered directly to an exposed surface on the PCB in order to achieve optimal thermal conduction. Thermal vias are used to transfer heat to other layers of the PCB.

The load supply pin, VBB, should be decoupled with an electrolytic capacitor (typically 100  $\mu$ F) in parallel with a lower valued ceramic capacitor placed as close as practicable to the device.

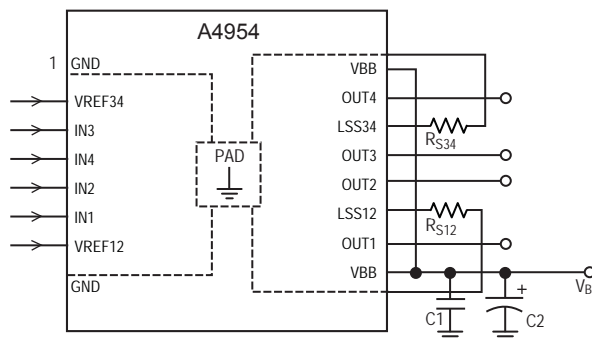
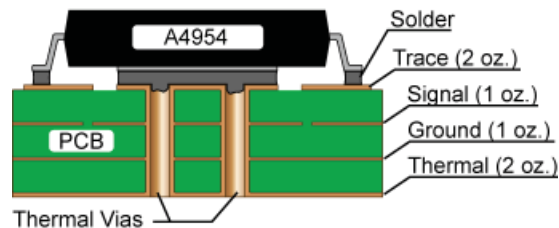
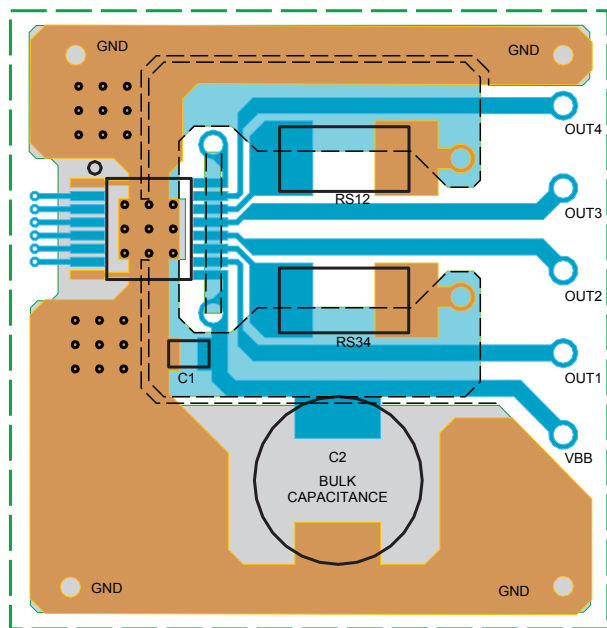

### Bill of Materials

Item	Reference	Value	Units	Description
1	RS12, RS34	0.25 (for $V_{REF} = 5$ V, $I_{OUT} = 2$ A)	$\Omega$	2512, 1 W, 1% or better, carbon film chip resistor
2	C1	0.22	$\mu$ F	X5R minimum, 50 V or greater
3	C2	100	$\mu$ F	Electrolytic, 50 V or greater

Package LP, 16-Pin TSSOP  
with exposed thermal pad

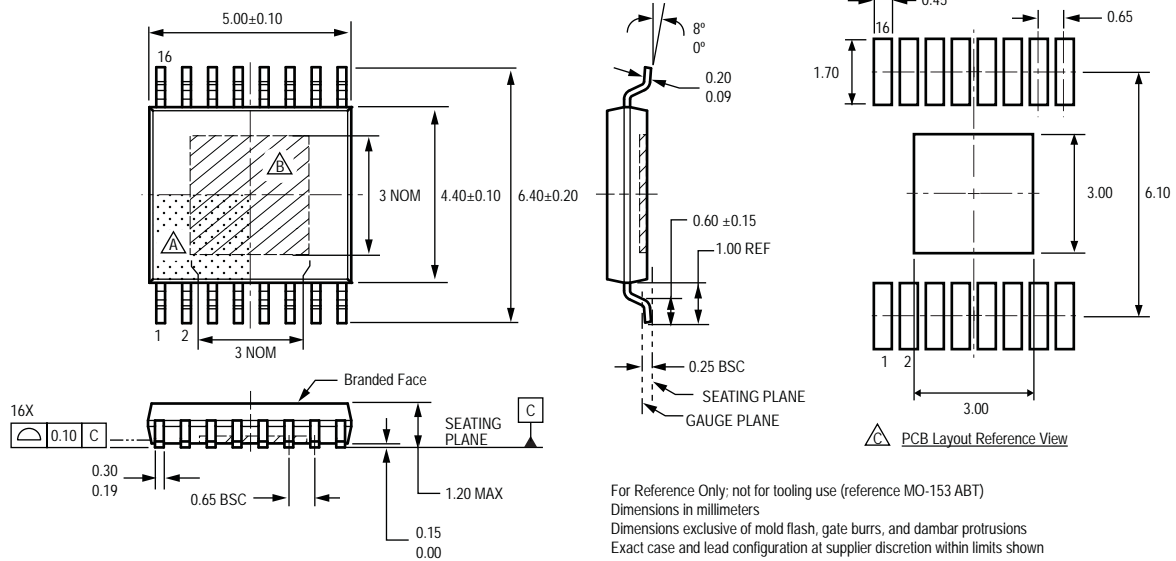

For Reference Only; not for tooling use (reference MO-153 ABT)  
Dimensions in millimeters  
Dimensions exclusive of mold flash, gate burrs, and dambar protrusions  
Exact case and lead configuration at supplier discretion within limits shown

- △ Terminal #1 mark area
- △ Exposed thermal pad (bottom surface); dimensions may vary with device
- △ Reference land pattern layout (reference IPC7351 SOP65P640X110-17M):  
All pads a minimum of 0.20 mm from all adjacent pads; adjust as necessary to meet application process requirements and PCB layout tolerances; when mounting on a multilayer PCB, thermal vias at the exposed thermal pad land can improve thermal dissipation (reference EIA/JEDEC Standard JESD51-5)



**Revision History**

Revision	Revision Date	Description of Revision
Rev. 4	August 6, 2012	Update PWM table

Copyright ©2010-2012, Allegro MicroSystems, Inc.

Allegro MicroSystems, Inc. reserves the right to make, from time to time, such departures from the detail specifications as may be required to permit improvements in the performance, reliability, or manufacturability of its products. Before placing an order, the user is cautioned to verify that the information being relied upon is current.

Allegro's products are not to be used in life support devices or systems, if a failure of an Allegro product can reasonably be expected to cause the failure of that life support device or system, or to affect the safety or effectiveness of that device or system.

The information included herein is believed to be accurate and reliable. However, Allegro MicroSystems, Inc. assumes no responsibility for its use; nor for any infringement of patents or other rights of third parties which may result from its use.

For the latest version of this document, visit our website:

[www.allegromicro.com](http://www.allegromicro.com)

