

Linear Systems replaces discontinued Siliconix J109

This n-channel JFET is optimised for low noise high performance switching. The part is particularly suitable for use in low noise audio amplifiers. The TO-92 package is well suited for cost sensitive applications and mass production.

(See Packaging Information).

J109 Benefits:

- Low On Resistance
- Low insertion loss
- Low Noise

J109 Applications:

- Analog Switches
- Commutators
- Choppers

FEATURES

DIRECT REPLACEMENT FOR SILICONIX J109

LOW ON RESISTANCE $r_{DS(on)} \leq 12\Omega$

FAST SWITCHING $t_{(on)} \leq 4ns$

ABSOLUTE MAXIMUM RATINGS @ 25°C (unless otherwise noted)

Maximum Temperatures

Storage Temperature $-55^{\circ}C$ to $+150^{\circ}C$

Operating Junction Temperature $-55^{\circ}C$ to $+150^{\circ}C$

Maximum Power Dissipation

Continuous Power Dissipation 350mW

MAXIMUM CURRENT

Gate Current (Note 1) 50mA

MAXIMUM VOLTAGES

Gate to Drain Voltage $V_{GDS} = -25V$

Gate to Source Voltage $V_{GSS} = -25V$

J109 ELECTRICAL CHARACTERISTICS @ 25°C (unless otherwise noted)

SYMBOL	CHARACTERISTIC	MIN	TYP.	MAX	UNITS	CONDITIONS
BV_{GSS}	Gate to Source Breakdown Voltage	-25	--	--	V	$I_G = 1\mu A, V_{DS} = 0V$
$V_{GS(off)}$	Gate to Source Cutoff Voltage	-2	--	-6		$V_{DS} = 5V, I_D = 1\mu A$
$V_{GS(F)}$	Gate to Source Forward Voltage	--	0.7	--		$I_G = 1mA, V_{DS} = 0V$
I_{DSS}	Drain to Source Saturation Current (Note 2)	40	--	--	mA	$V_{DS} = 15V, V_{GS} = 0V$
I_{GSS}	Gate Reverse Current	--	-0.01	-3	nA	$V_{GS} = -15V, V_{DS} = 0V$
I_G	Gate Operating Current	--	-0.01	--		$V_{DG} = 10V, I_D = 10mA$
$I_{D(off)}$	Drain Cutoff Current	--	0.02	3		$V_{DS} = 5V, V_{GS} = -10V$
$r_{DS(on)}$	Drain to Source On Resistance	--	--	12	Ω	$V_{GS} = 0V, V_{DS} \leq 0.1V$

J109 DYNAMIC ELECTRICAL CHARACTERISTICS @ 25°C (unless otherwise noted)

SYMBOL	CHARACTERISTIC	MIN	TYP.	MAX	UNITS	CONDITIONS
g_{fs}	Forward Transconductance	--	17	--	mS	$V_{DS} = 5V, I_D = 10mA, f = 1kHz$
g_{os}	Output Conductance	--	0.6	--		
$r_{DS(on)}$	Drain to Source On Resistance	--	--	12	Ω	$V_{GS} = 0V, I_D = 0A, f = 1kHz$
C_{iss}	Input Capacitance	--	60	85	pF	$V_{DS} = 0V, V_{GS} = 0V, f = 1MHz$
C_{rss}	Reverse Transfer Capacitance	--	11	15		$V_{DS} = 0V, V_{GS} = -10V, f = 1MHz$
e_n	Equivalent Noise Voltage	--	3.5	--	nV/√Hz	$V_{DS} = 5V, I_D = 10mA, f = 1kHz$

J109 SWITCHING CHARACTERISTICS @ 25°C (unless otherwise noted)

SYMBOL	CHARACTERISTIC	UNITS	CONDITIONS
$t_{d(on)}$	Turn On Time	3	$V_{DD} = 1.5V$ $V_{GS(H)} = 0V$ See Switching Circuit
t_r	Turn On Rise Time	1	
$t_{d(off)}$	Turn Off Time	4	
t_f	Turn Off Fall Time	18	

Note 1 - Absolute maximum ratings are limiting values above which J109 serviceability may be impaired. Note 2 – Pulse test: $PW \leq 300 \mu s$, Duty Cycle $\leq 3\%$

J109 SWITCHING CIRCUIT PARAMETERS

$V_{GS(L)}$	-7V
R_L	150 Ω
$I_{D(on)}$	10mA

Available Packages:

J109 in TO-92
J109 in bare die.

TO-92 (Bottom View)

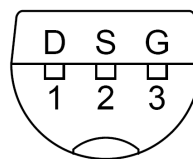

Please contact Micross for full package and die dimensions

SWITCHING TEST CIRCUIT

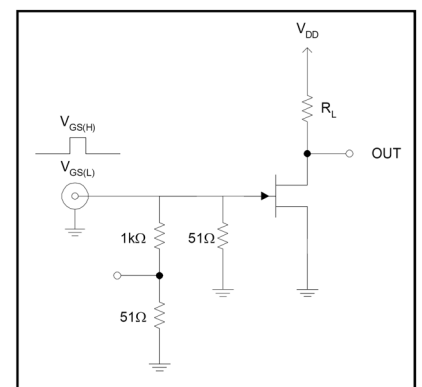

Micross Components Europe



Tel: +44 1603 788967

Email: chipcomponents@micross.com

Web: <http://www.micross.com/distribution>