

DASH NO

M CODE

MADE FROM

1209-2-15MA9

REVISIONS

ISSUE	CHANGES
3	CN 18981A MJB 2 JAN 79
4	CN 32904 C KH 18 MAR 91

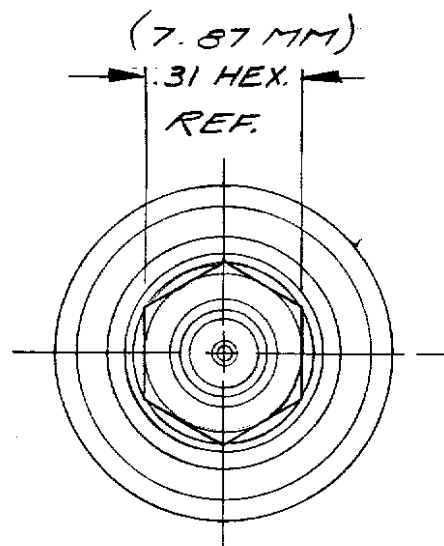
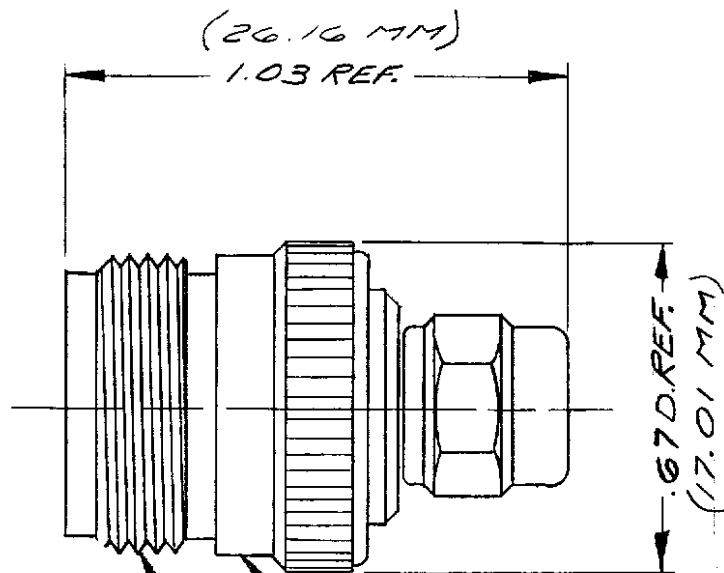

STAMP: KINGS 1209-2-15MA9

 $\frac{5}{8}$ -24 NEF-2 THREAD

NOTES:

1. MATERIALS:

INSULATOR-TEFLON, ASTM-D-1457
 GASKET-SILICONE RUBBER, ZZ-R-765
 SMA CONTACT M-BRASS; QQ-B-626
 ALL OTHER METAL PARTS-BER. COP., ASTM-B-196

2. FINISHES:

ALL METAL PARTS-GOLD PLT. PER MIL-G-45204

3. ELECTRICAL CHARACTERISTICS:

NOMINAL IMPEDANCE: 50 Ω
 VOLTAGE RATING: 350 VOLTS
 FREQUENCY RANG: DC-11 GHZ
 AVERAGE VSWR: LESS THAN 1.15

S-D

SCALE:

APPROX. SURFACE AREA:

USED ON:

REF:

N(F) TO SMA(M)
 ADAPTOR

DRAWN/PAS

DATE 3 MAR 81

APPR. MJB

DATE 6 MAR 81

KINGS
 ELECTRONICS CO., INC.
 TUCKAHOE, NEW YORK 10707

1209-2-15MA9

S-D

UNLESS OTHERWISE SPECIFIED:

1. TOLERANCES: FRACTIONS & 2 PLACE DECIMALS $\pm .010$
 3 PLACE DECIMALS $\pm .004$ ANGLES $\pm 0^{\circ}30'$
 T. I. R. CONCENTRICITY OF ANY 2 DIAMETERS MAY
 NOT EXCEED HALF THE SUM OF THEIR TOLERANCES.

2. REMOVE ALL BURRS, BREAK SHARP EDGES .005 MAX.
 3. NO FILLETS PERMITTED.
 4. SURFACE ROUGHNESS 63 MICROINCHES RMS MAX.
 5. ALL DIMENSIONS PRIOR TO PLATING.
 6. ALL PLATING IN ACCORDANCE WITH KER 10004.