

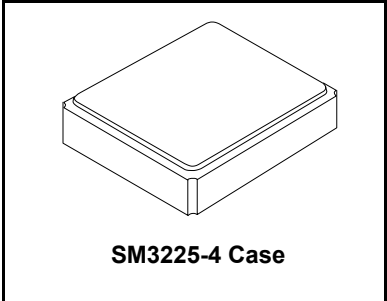

- Voltage Controlled Temperature Compensated Crystal Oscillator
- Excellent Frequency Stability & Low Phase Noise
- 3.2 x 2.5 x 1.2 mm Surface-mount Case
- Complies with Directive 2002/95/EC (RoHS) 

XVT9010

**10.000000 MHz
VCTCXO**



Electrical Characteristics

Characteristic	Sym	Notes	Minimum	Typical	Maximum	Units
Nominal Frequency	fo			10.000000		MHz
Component Storage Temperature Range			-55		+125	°C
Storage Temperature Range in Tape and Reel			-40		+85	°C
Soldering Profile, 10 seconds, up to 5 cycles					260	°C
Operating Temperature Range			-40		+85	°C
Power Supply Voltage	Vcc		3.14	3.30	3.46	V
Output Voltage with Load 10 pF 10 KΩ	Vout		0.8			V _{P-P}
Output Waveform			clipped sinewave			
Power Supply Current	Icc				2.0	mA
Control Voltage	Vcon			1.5±1.0		V
Control Voltage Input Impedance			100K			ohms
Frequency Tolerance, Vcontrol = 1.50 V			±1.0 ppm max @ 25 °C ±2 °C			
Frequency Stability versus:						
Temperature, -40 to 85 °C				±0.5		ppm
Supply Voltage, 3.14 to 3.46 V				±0.2		ppm
Load 10 pF 10 KΩ ±10%				±0.2		ppm
Control Voltage Frequency Range (1.5 ±1.0 V)			±5			ppm/V
Start Up Time, 90% of final RF level in V _{P-P}					2.0	ms
Aging @ 25 °C				±1		ppm/year
Harmonics					-5.0	dBc
SSB Phase Noise @ 1 kHz Carrier Offset					-135	dBc/Hz
Standard Shipping Quantity on 180 mm (7") Reel				1000		units
Lid Symbolization			9010 - YWWS			



CAUTION: Electrostatic Sensitive Device. Observe precautions for handling.

Notes:

1. The design, manufacturing process, and specifications of this device are subject to change without notice.

SM3225-4 Case

4-Terminal Surface-Mount Seam Weld Case 3.2 x 2.5 mm Nominal Footprint

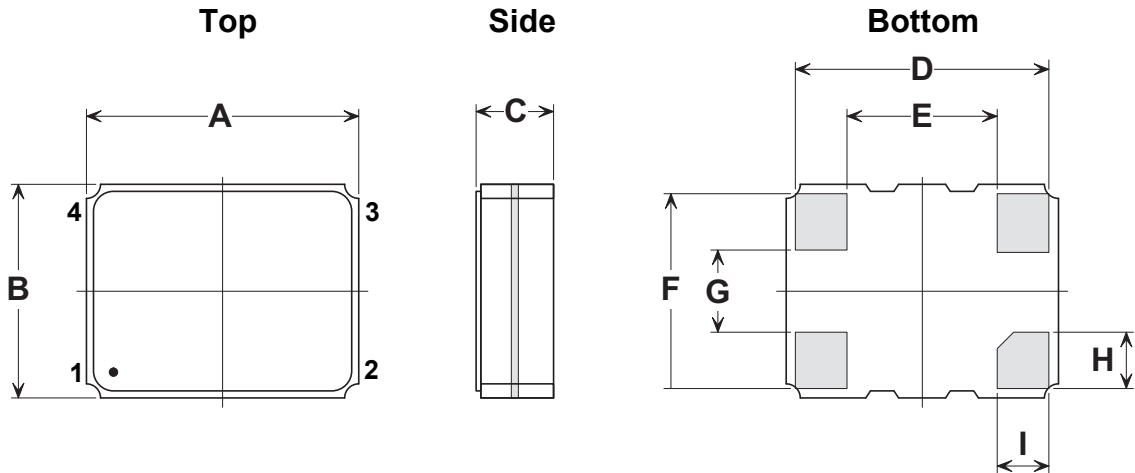

Typical PCB Land Pattern

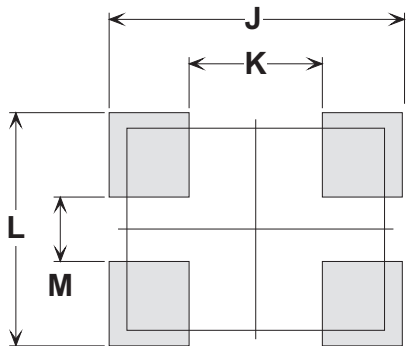

Dimension	mm			Inches		
	Min	Nom	Max	Min	Nom	Max
A	3.00	3.20	3.40	0.118	0.126	0.133
B	2.30	2.50	2.70	0.091	0.098	0.106
C	-	-	1.20	-	-	0.047
D	-	3.08	-	-	0.121	-
E	-	1.80	-	-	0.071	-
F	-	2.38	-	-	0.094	-
G	-	1.00	-	-	0.039	-
H	-	0.65	-	-	0.026	-
I	-	0.60	-	-	0.024	-
J	-	3.60	-	-	0.142	-
K	-	1.60	-	-	0.063	-
L	-	2.90	-	-	0.114	-
M	-	0.80	-	-	0.031	-

Application Circuit

Pin	Connection
1	V _{control}
2	GND/CASE GND
3	Output
4	V _{cc}

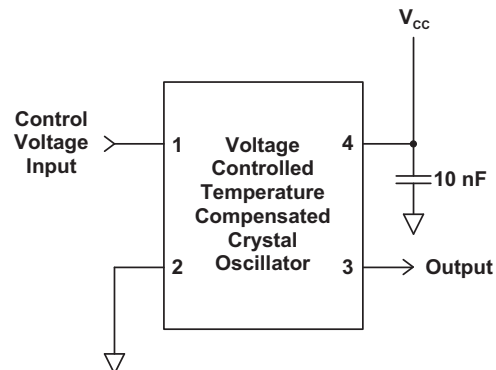

Reel Dimensions

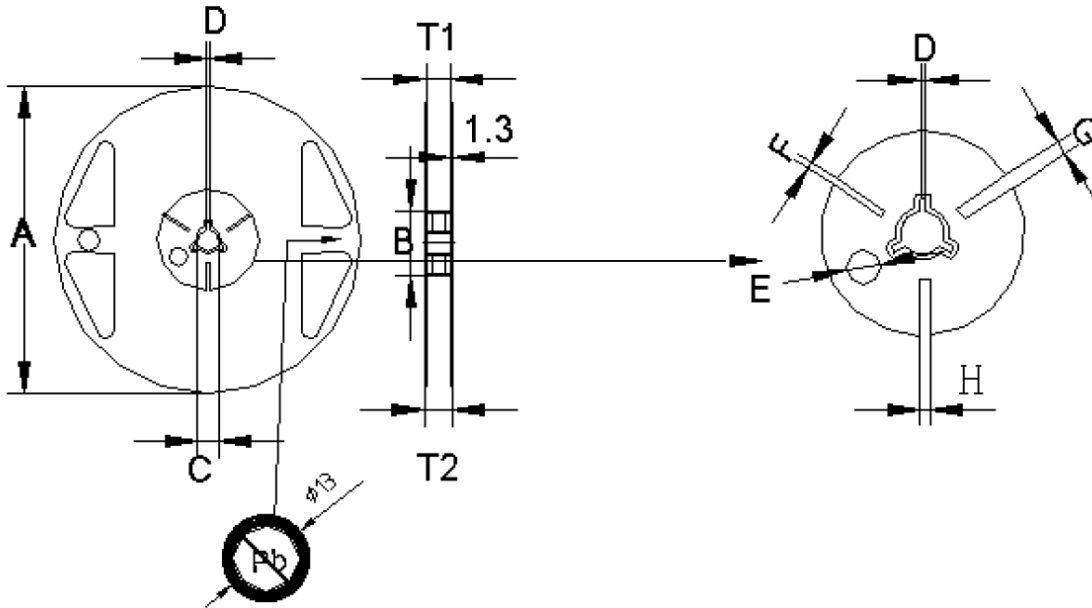

mm	A	B	C	D	E	F	G	H	T1	T2	T3
Dimension	180	60	13.0	2.0	9.1	2.9	4.9	3.9	9.0	11.4	1.2
Tolerance	±1.0	+1.0/-0.0	±0.2	±0.5	±0.5	±0.5	±0.5	±0.5	±0.3	±1.0	±0.1

Tape Dimensions

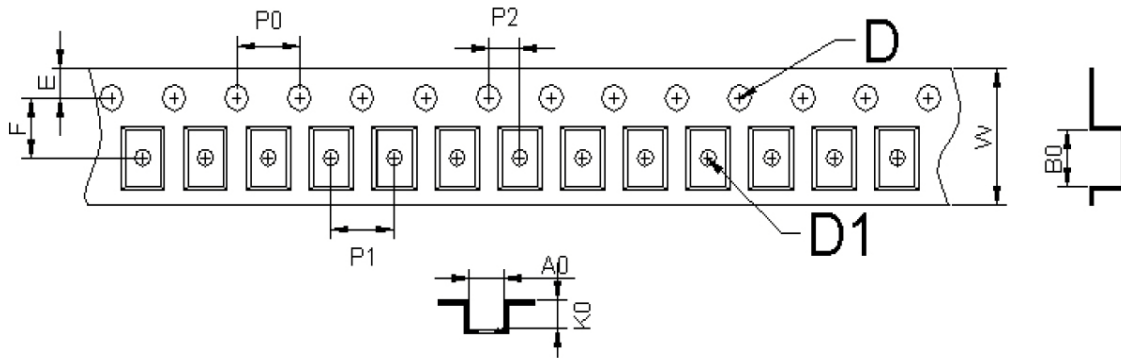

mm	A0	B0	W	F	E	P0	P1	P2	D1	D	K0	t
Dimension	2.80	3.71	8.00	3.50	1.75	4.00	4.00	2.00	1.50	1.00	1.75	0.25
Tolerance	±0.10	±0.10	+0.30/-0.10	±0.05	±0.10	±0.10	±0.10	±0.05	+0.10/-0.00	+0.25/-0.00	±0.10	±0.02