

Photodiode module C10439 series



Integrates a Si photodiode for precision photometry with low-noise amp

C10439 series photodiode modules are high-precision photodetectors that integrate a Si photodiode and a current-to-voltage amplifier. The output from these photodiode modules is an analog voltage and can be easily checked with a voltmeter, etc. Since their sensitivity is switchable between two ranges (High/Low), highly accurate output can be obtained by selecting the proper sensitivity range that matches the light level to be detected. C10439 series is available with three different active areas.

Features

- Voltage output for easy handling
- Two-range (High/Low) switching function
- Only half size of a business card
- Can be mounted on optical bench rod (M4)
- Choice of active areas
C10439-01: 2.4 × 2.4 mm
C10439-02: 5.8 × 5.8 mm
C10439-03: 10 × 10 mm

Applications

- Precision photometry
- Light source power monitors
- Fluorescence detection of printed matter
- Illuminometers
- Color difference meters
- Refractometer
- Flowmeters, etc.

■ Absolute maximum ratings (Ta=25 °C)

Parameter	Symbol	Value	Unit
Supply voltage	Vcc Max.	±13	V
Operating temperature *1	Topr	0 to +50	°C
Storage temperature *1	Tstg	-10 to +60	°C

*1: No condensation

■ Recommended operating range

Parameter	Symbol	Min.	Typ.	Max.	Unit
Supply power voltage	Vcc	±5	-	±12	V

■ Electrical and optical characteristics (Ta=25 °C, Vcc=±12 V, unless otherwise noted)

Parameter	Symbol	Condition	Min.	Typ.	Max.	Unit
Spectral response range	λ		-	190 to 1100	-	nm
Peak sensitivity wavelength	λ_p		-	960	-	nm
Saturation input optical power		High range, $\lambda=\lambda_p$	-	23	-	nW
		Low range, $\lambda=\lambda_p$	-	2360	-	
Photo sensitivity	S	High range, $\lambda=\lambda_p$	-	500	-	mV/nW
		Low range, $\lambda=\lambda_p$	-	5	-	
Frequency bandwidth (-3 dB)	fc	High range	DC	10	-	Hz
		Low range	DC	1000	-	
Conversion impedance	Zt	High range	-	1×10^9	-	V/A
		Low range	-	1×10^7	-	
Maximum output amplitude	Vfs	Vcc=±5 to ±12 Output current Io=1 mA	+Vcc - 0.5	+Vcc - 0.2	-	V
Dark voltage	Vd	Dark state	-5	-	+5	mV
Time drift (drift over time)	-	Dark state Ta=25 °C *2	-0.5	-	+0.5	mV/day
Output noise voltage width	Vn	Dark state, within frequency band	-	2	5	mVp-p
Capacitive load	CL		500	-	-	pF
Output resistance	Zo		-	100	-	Ω
Current consumption	Icc	Dark state	-	-	±2	mA

*2: Dark voltage variation per day, measured at 25 °C after a 10-minute warm-up after power-on.

■ Block diagram

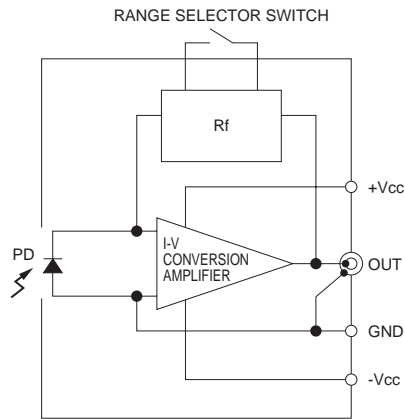

KACCC0364EA

■ Output voltage vs. input light

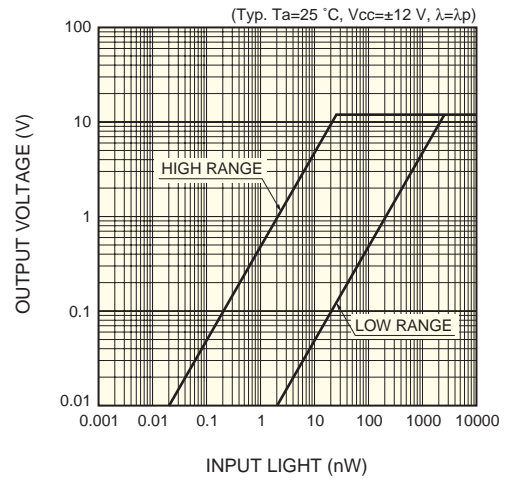

KACCB0172EA

■ Spectral response

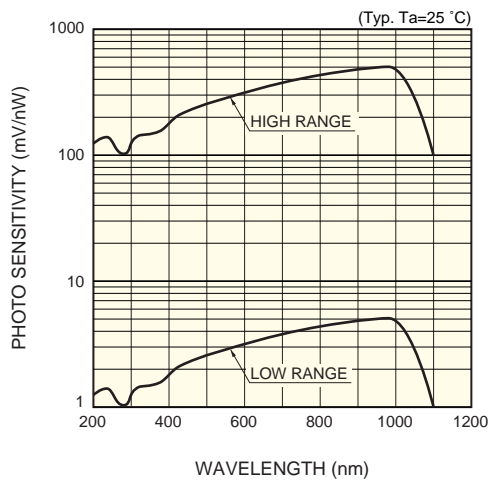

KACCB0153EA

■ Dimensional outlines (unit: mm, tolerance: ± 0.2 mm unless otherwise noted)

C10439-01

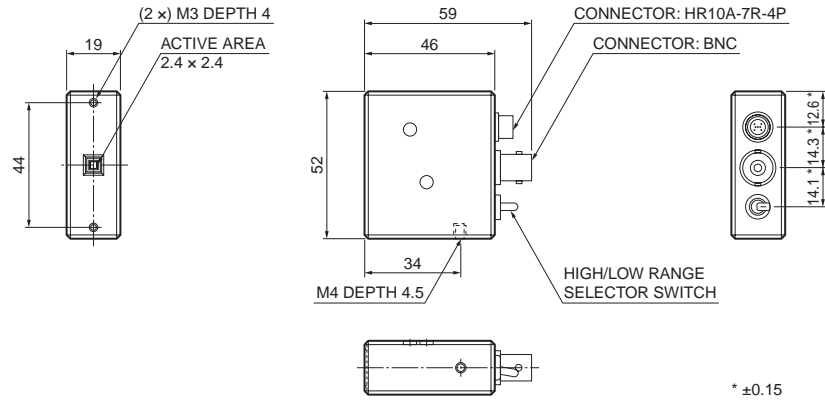

KACCA0203EA

C10439-02

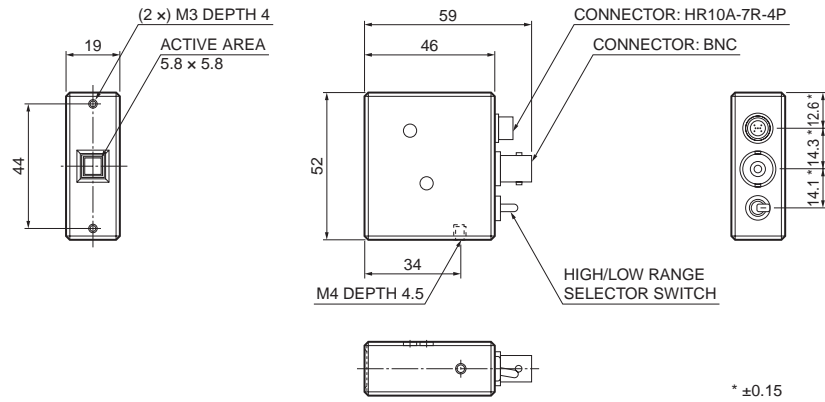

KACCA0204EA

C10439-03

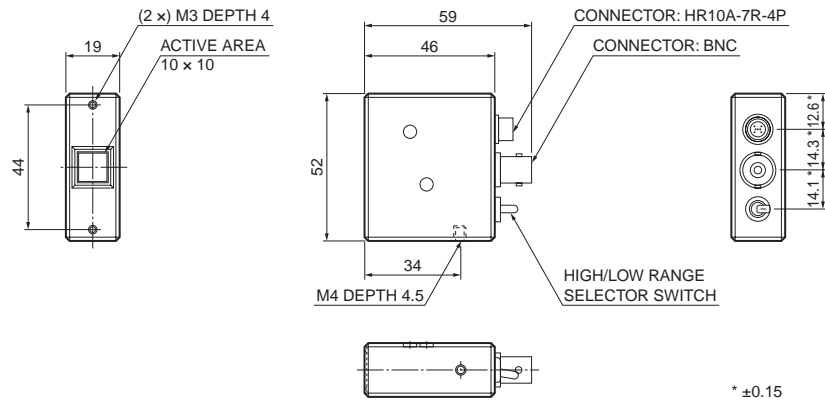

KACCA0205EA

■ Connection examples

Connection with DC voltmeter, oscilloscope, etc.

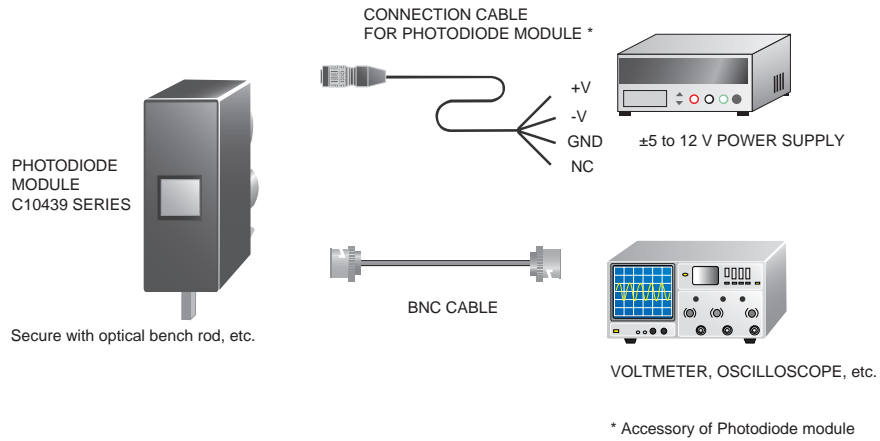

Connection with signal processing unit for photodiode module

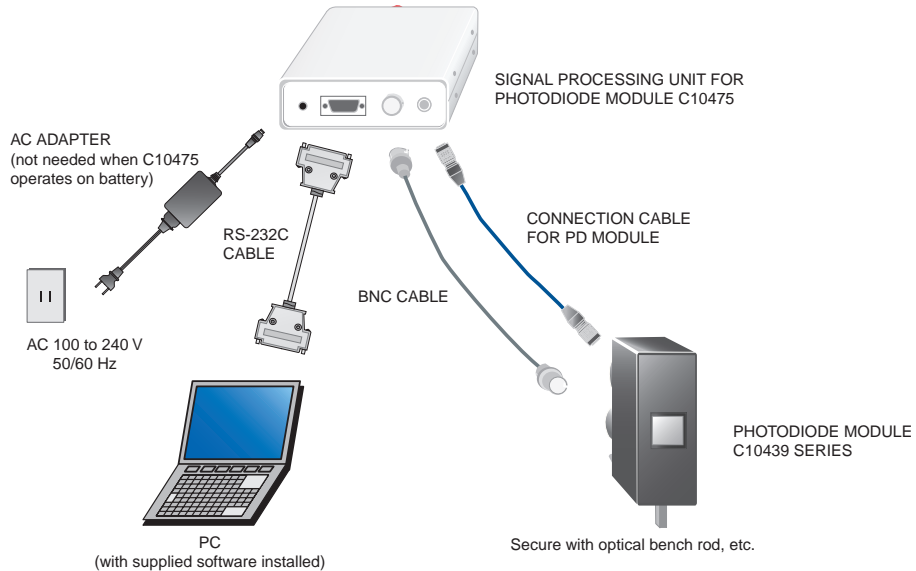

■ Accessory

- Cable for power supply: length 1 m (no connector on one end)

HAMAMATSU

Information furnished by HAMAMATSU is believed to be reliable. However, no responsibility is assumed for possible inaccuracies or omissions. Specifications are subject to change without notice. No patent rights are granted to any of the circuits described herein. ©2008 Hamamatsu Photonics K.K.

HAMAMATSU PHOTONICS K.K., Solid State Division

1126-1 Ichino-cho, Higashi-ku, Hamamatsu City, 435-8558 Japan, Telephone: (81) 53-434-3311, Fax: (81) 53-434-5184, www.hamamatsu.com

U.S.A.: Hamamatsu Corporation: 360 Foothill Road, P.O.Box 6910, Bridgewater, N.J. 08807-0910, U.S.A., Telephone: (1) 908-231-0960, Fax: (1) 908-231-1218

Germany: Hamamatsu Photonics Deutschland GmbH: Arzbergerstr. 10, D-82211 Herrsching am Ammersee, Germany, Telephone: (49) 08152-3750, Fax: (49) 08152-2658

France: Hamamatsu Photonics France S.A.R.L.: 19, Rue du Saule Trapu, Parc du Moulin de Massy, 91882 Massy Cedex, France, Telephone: 33-(1) 69 53 71 00, Fax: 33-(1) 69 53 71 10

United Kingdom: Hamamatsu Photonics UK Limited: 2 Howard Court, 10 Tewin Road, Welwyn Garden City, Hertfordshire AL7 1BW, United Kingdom, Telephone: (44) 1707-294888, Fax: (44) 1707-325777

North Europe: Hamamatsu Photonics Norden AB: Smidesvägen 12, SE-171 41 Solna, Sweden, Telephone: (46) 8-509-031-00, Fax: (46) 8-509-031-01

Italy: Hamamatsu Photonics Italia S.R.L.: Strada della Moia, 1/E, 20020 Arese, (Milano), Italy, Telephone: (39) 02-935-81-733, Fax: (39) 02-935-81-741

Cat. No. KACC1139E02
Feb. 2008 DN