

NOTES: UNLESS OTHERWISE SPECIFIED

1. FOR GENERAL SERIES SPECIFICATIONS, SEE SD74-0000.
2. MATERIAL SPECIFICATIONS: BERYLLIUM COPPER PER ASTM B196 OR B05 PER UNS 53800.
3. FINISH SPECIFICATIONS:  
.000030 MIN. GOLD PER ASTM B488 OVER .000050 MIN. NICKEL PER AMS QQ-N-290.
4. ELECTRICAL SPECIFICATIONS:  
CURRENT RATING: 30 AMPS
5. SUGGESTED FOR USE WITH 12 GA WIRE OR EQUIVALENT.
6. REFER TO CAP10-01 FOR CABLE ASSEMBLY PROCEDURE.

REV	DESCRIPTION	BY DATE	APPD
E	REVISED PER ER17032	07/30/09 KEY	CTC

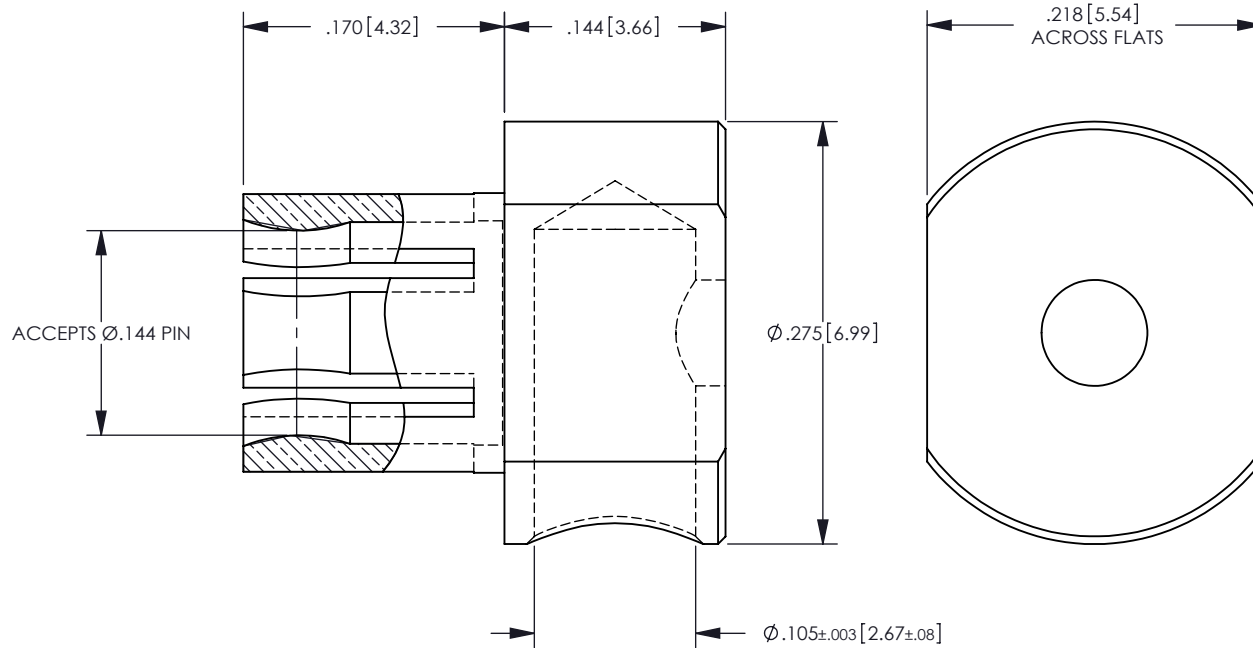

CATALOG P/N: 01359

PER ASME Y14.5M-1994 UNLESS OTHERWISE SPECIFIED: DIMENSIONS ARE IN INCHES [MM] TOLERANCES: DECIMAL: .XX ± .01 [0.3] .XXX ± .005 [0.13] .XXXX ± .XXXX ANGLES: ± 2°		SCALE: 8:1	
DRAWN JEM 08/12/03		APPROVED CWB 08/12/03	
APPROVED JED 08/12/03		APPROVED MG 08/12/03	
CUSTOMER DRAWING		WINCHESTER ELECTRONICS Winchester Electronics Corporation 62 Barnes Industrial Road North Wallingford, Connecticut 06492	
POWERSNAP RIGHT ANGLE SOLDER MOUNT 12 AWG, 30 AMP		A SD01359 SHT 1 OF 1 REV E	

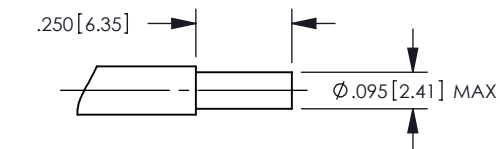

RECOMMENDED CABLE TRIM DIMENSIONS  
SCALE: 2:1