

10Base-T Interface Module

EPE6119G & EPE6119G-RC



- General Purpose 10Base-T Filter Module
- Robust construction allows for toughest reflow processing
- Complies with or exceeds IEEE 802.3, 10Base-T Standards
- Add “-RC” after part number for RoHS Compliant
- Operating Temperature : 0°C to +70°C
- Storage Temperature : -40°C to +125°C
- Peak Solder Rating (See Note 2)

Electrical Parameters @ 25° C

Cut-Off Frequency (MHz)	Insertion Loss (dB Max.)	Return Loss (dB Min.)	Attenuation (dB Min.)				Common Mode Rejection (dB Min.)	Crosstalk (dB Min.)
			@ 20 MHz	@ 25 MHz	@ 30 MHz	50-100 MHz		
± 1.0 MHz	1-10 MHz	5-10 MHz	Xmit/Rcv	Xmit/Rcv	Xmit/Rcv	Xmit/Rcv	1-100 MHz	1-10 MHz
Xmit/Rcv	Xmit/Rcv	Xmit/Rcv	Xmit/Rcv	Xmit/Rcv	Xmit/Rcv	Xmit/Rcv	Xmit/Rcv	
17/17	-1/-1	-15/-15	-7/-6	-18/-14	-30/-20	-32/-31	-30/-30	-35

- **Isolation** : Meets or exceeds 802.3 IEEE Requirements
- **Characteristic Filter Impedance** : 100

Package

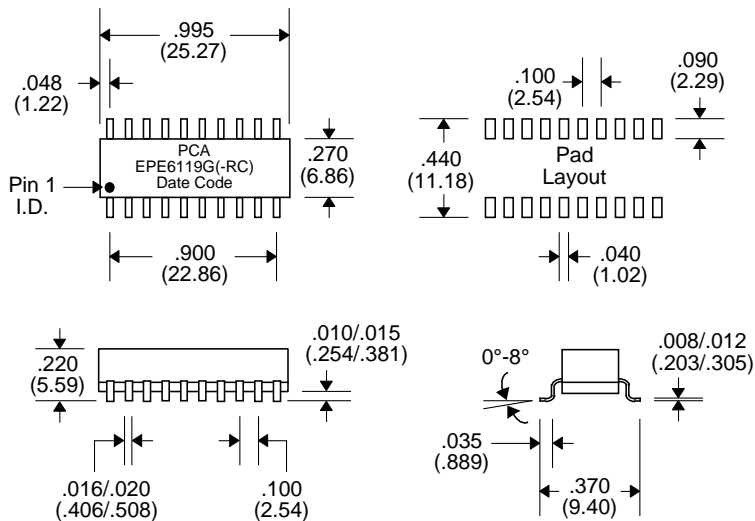

Schematic

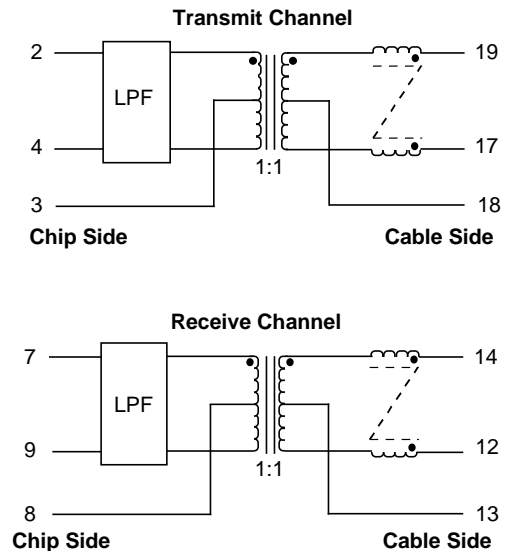

Notes :	EPE6119G	EPE6119G-RC
1. Lead Finish	SnPb	Hot Tin Dip (Sn)
2. Peak Temperature Rating	225°C	245°C
3. Moisture Sensitive Levels	MSL = 3	MSL = 3
4. Weight	1.85 grams	1.85 grams
5. Packaging Information	(Tube)	19 pieces/tube
	(Tape & Reel)	550 pieces/13" reel
		550 pieces/13" reel

Unless Otherwise Specified Dimensions are in Inches /mm ± .010 / .25