

## SPB-9610LVWG

**(RoHS Compliant)**

**1310 nm TX / 1550 nm RX / 3 Gb/s Medium Power 1-Fibre SM Video Digital Diagnostic SFP Transceiver**

### FEATURES

- I SMPTE 297-2006 Compatible
- I **1-Fiber Bi-Directional SFP Optical Transceiver**
- I Small Form-Factor Pluggable (SFP) MSA compatible
- I Speed from 50 Mbps to 3Gbps with up to 30 km Single-mode Fiber
- I Distance up to 10 km for 3G-SDI
- I **Support Video Pathological Patterns for SD-SDI, HD-SDI and 3G-SDI**
- I 1310 nm Transmitter
- I 1550 nm Receiver
- I SFF-8472 Digital Diagnostic Function
- I Simplex LC Connector
- I Single +3.3 V Power Supply
- I RoHS-6 Compliant
- I 0 to 70°C Operation
- I Hot Pluggable
- I Class 1 Laser International Safety Standard IEC-60825 Compliant

### APPLICATIONS

- I SMPTE 297-2006 Compliant Electrical-to-Optical Interfaces
- I High-density Video Routers

### DESCRIPTION

The SPB-9610LVWG is a 1-fibre BIDI single mode transceiver module designed to transmit/receive optical serial digital signals as defined in SMPTE 297-2006. It supports from 50 Mbps to 3 Gbps and is specifically designed for transmitted the SMPTE 259M, SMPTE 344M, SMPTE 292M and SMPTE 424M SDI pathological patterns. It is with the SFP 20-pin connector to allow hot plug capability. Digital diagnostic functions are available via an I<sup>2</sup>C. It is with 1310 nm laser transmitters. The receiver section uses an integrated 1550 nm detector preamplifier (IDP) mounted in an optical header and a limiting post-amplifier IC. The transmitter can transmit signal from 50 Mbps to 3 Gbps with up to 30 km of single-mode fiber. A maximum distance of 10 km is achievable with 3Gbps pathological signals.

### LASER SAFETY

This single mode transceiver is a Class 1 laser product. It complies with IEC-60825 and FDA 21 CFR 1040.10 and 1040.11. The transceiver must be operated within the specified temperature and voltage limits. The optical ports of the module shall be terminated with an optical connector or with a dust plug.

### ORDER INFORMATION

P/No.	Type	Bit Rate (Mb/s)	TX		RX		Package	Temp (°C)	RoHS Compliant
			λ (nm)	Power (dBm)	λ (nm)	Sen. (dBm)			
<b>SPB-9610LVWG</b>	transceiver	50 to 3000	1310	0 to -5	1550	0 to -20	LC SFP with DMI	0 to 70	Yes
<b>SPB-9710LVWG</b>	transceiver	50 to 3000	1550 DFB	-3 to -8	1310	0 to -20	LC SFP with DMI	0 to 70	Yes

### LINK DISTANCE

SDI	Bit Rate	Max. Link Distance (km)
3G-SDI	2.97Gbps	10
HD-SDI	1.485Gbps	21
SD-SDI	270Mbps	30

## Absolute Maximum Ratings

Exposure to absolute maximum rating conditions for extended periods may affect device reliability.

Absolute Maximum Ratings					
Parameter	Symbol	Min	Max	Units	Notes
Storage Temperature	Tstg	-40	85	°C	
Operating Case Temperature	Tc	0	70	°C	
Power Supply Voltage	Vcc	0	4	V	
ESD Tolerance on all pins			1	KV HBM	
Relative Humidity	---	5	95	% RH	non-condensing

Recommended Operating Conditions					
Parameter	Symbol	Min	Typ	Max	Units / Notes
Power Supply Voltage	Vcc	3.13	3.3	3.47	V
Operating Case Temperature	Tc	0		70	°C
Baud Rate		50		3000	Mb/s
Power Supply Current	Icc		200	300	mA

Transmitter Specifications (0°C < Tc < 70°C, 3.13V < Vcc < 3.47V)						
Parameter	Symbol	Min	Typ	Max	Units	Notes
<b>Optical</b>						
Optical Transmit Power	Po	-5	-2	0	dBm	1
Output Center Wavelength	$\lambda$	1260	1310	1360	nm	
Output Spectrum Width	$\Delta\lambda$	---	1.5	3	nm	RMS ( $\sigma$ )
Extinction Ratio	ER	5	7.5		dB	
Relative Intensity Noise	RIN			-120	dB/Hz	
Optical Rise Time / Fall Time	tr / tf			135	ps	2, SMPTE 424M
				270	ps	2, SMPTE 292M
				800	ps	2, SMPTE 344M
				1.5	ns	2, SMPTE 259M
<b>Electrical</b>						
Differential Input Voltage	$V_{IH} - V_{IL}$	200		1200	mVp-p	AC coupled input
Disable Input Voltage -- Low	$V_{TDIS,L}$	0		0.8	V	TX Output Enabled
Disable Input Voltage -- High	$V_{TDIS,H}$	2.0		Vcc+0.3	V	TX Output Disabled
SCL, SDA	$V_{OH}$	2.5		Vcc+0.3	V	
	$V_{OL}$	0		0.5	V	

- Output power is power coupled into a 9/125  $\mu$ m single mode fiber.
- 20% to 80%, unfiltered.

Receiver Specifications (0°C < Tc < 70°C, 3.13V < Vcc < 3.47V)						
Parameter	Symbol	Min	Typ	Max	Units	Notes
<b>Optical</b>						
Wavelength of Operation		1480	---	1580	nm	3
Sensitivity for SMPTE 424M 2.97 Gb/s	Sen	0	---	-18	dBm	Pathological
		0	---	-20	dBm	PRBS 2 <sup>23</sup> -1, BER=1E-12
Sensitivity for SMPTE 292M 1.485 Gb/s	Sen	0	---	-20	dBm	Pathological
		0	---	-21	dBm	PRBS 2 <sup>23</sup> -1, BER=1E-12
Signal Detect -- Asserted	Pa	---	---	-23	dBm	Transition: low to high
Signal Detect -- Deasserted	Pd	-29	---	---	dBm	Transition: high to low
Signal detect -- Hysteresis		1		6	dB	
Optical Return Loss			-27		dB	
<b>Electrical</b>						
CML Output (Differential)		550	660	850	mVp-p	AC coupled output

Optical Rise Time / Fall Time	tr / tf			135	ps	4, SMPTE 424M
				270	ps	4, SMPTE 292M
				800	ps	4, SMPTE 344M
				1.5	ns	4, SMPTE 259M
Output LOS Voltage -- Low	V <sub>OL</sub>	0		0.5	V	I <sub>OL</sub> =-1.6mA, 1 TTL unit load
Output LOS Voltage -- High	V <sub>OH</sub>	2.5		V <sub>CC</sub> +0.3	V	I <sub>OH</sub> =40μA, 1 TTL unit load
SCL, SDA	V <sub>OH</sub>	2.5		V <sub>CC</sub> +0.3	V	
	V <sub>OL</sub>	0		0.5	V	

- 3. At least 30 dB optical isolation for the wavelength 1260 to 1360 nm.
- 4. 20% to 80% , unfiltered.

## MODULE DEFINITION

Module Definition	PIN 5	PIN 6	Interpretation by Host
4	SCL	SDA	Serial module definition protocol

Module Definition 4 specifies a serial definition protocol. For this definition, upon power up, SCL and SDA appear as no connector (NC). When the host system detects this condition, it activates the serial protocol. The protocol uses the 2-wire serial CMOS E<sup>2</sup>PROM protocol of the ATMEL AT24C01A/02/04 family of components.

CONNECTION DIAGRAM



PIN	Signal Name	Description	PIN	Signal Name	Description
1	TX GND	Transmitter Ground	11	RX GND	Receiver Ground
2	TX Fault	Transmitter Fault Indication	12	RX DATA OUT-	Inverse Receiver Data Out
3	TX Disable	Transmitter Disable (Module disables on high or open)	13	RX DATA OUT+	Receiver Data Out
4	MOD-DFE2	Modulation Definition 2 – Two wires serial ID Interface	14	RX GND	Receiver Ground
5	MOD-DEF1	Modulation Definition 1 – Two wires serial ID Interface	15	Vcc RX	Receiver Power – 3.3V±5%
6	MOD-DEF0	Modulation Definition 0 – Ground in Module	16	Vcc TX	Transmitter Power – 3.3V±5%
7	N/C	Not Connected	17	TX GND	Transmitter Ground
8	LOS	Loss of Signal	18	TX DATA IN+	Transmitter Data In
9	RX GND	Receiver Ground	19	TX DATA IN-	Inverse Transmitter Data In
10	RX GND	Receiver Ground	20	TX GND	Transmitter Ground

MODULE DEFINITION

Module Definition	MOD-DEF2 PIN 4	MOD-DEF1 PIN 5	MOD-DEF0 PIN 6	Interpretation by Host
4	SDA	SCL	LV-TTL Low	Serial module definition protocol

Module Definition 4 specifies a serial definition protocol. For this definition, upon power up, MOD-DEF(1:2) appear as no connector (NC) and MOD-DEF(0) is TTL LOW. When the host system detects this condition, it activates the serial protocol. The protocol uses the 2-wire serial CMOS E<sup>2</sup>PROM protocol of the ATMEL AT24C01A/02/04 family of components.

## RECOMMENDED CIRCUIT SCHEMATIC

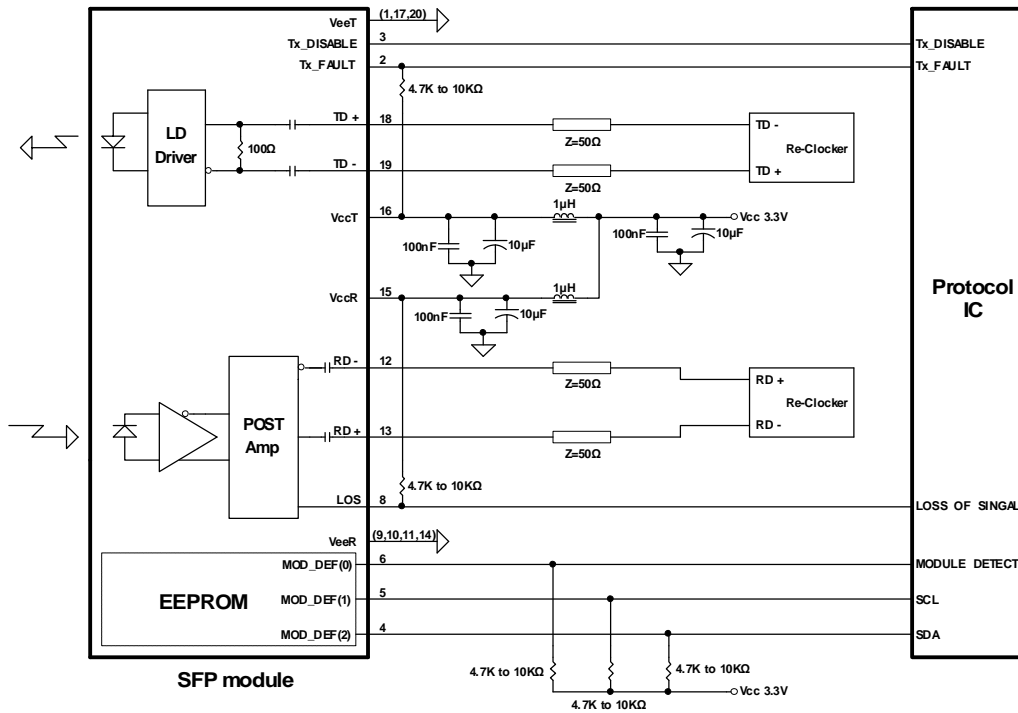

## PACKAGE DIAGRAM

Units in mm

Top View

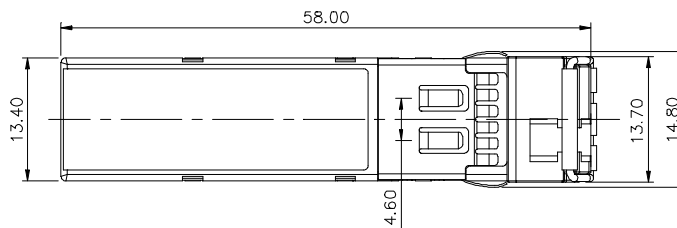

Front View

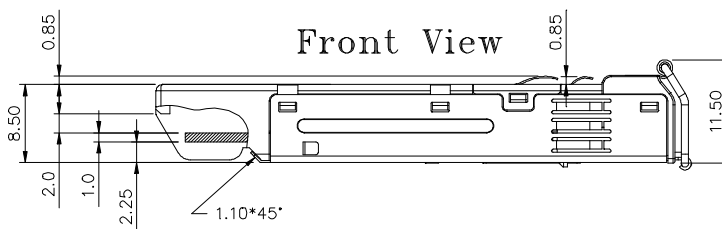

LATCH COLOR  
Blue

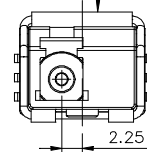

Side View

Bottom View

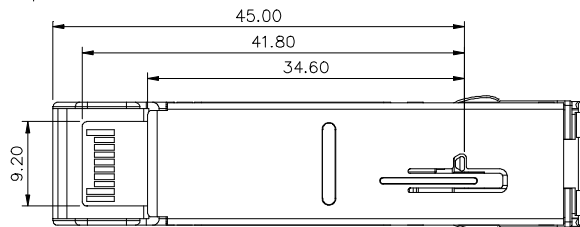

Note: Specifications subject to change without notice.

\*\*\*\*\*

## REVISION HISTORY

Version	Subject	Release Date
1.0	Initial datasheet	2008/10/1

\*\*\*\*\*