

## FEATURES

- ◆ Footprint from 1.46cm<sup>2</sup>
- ◆ I/O isolation voltage 1000VDC
- ◆ Operating Temperature: -40°C ~ +85°C
- ◆ High efficiency up to 86%
- ◆ Fully encapsulated toroidal magnetics
- ◆ Internal SMD construction
- ◆ Power density up to 1.44W/cm<sup>3</sup>
- ◆ No electrolytic or tantalum capacitors
- ◆ 5V, 9V, 12V and 15V output
- ◆ No heatsink required
- ◆ Dual output from a single input rail
- ◆ UL 94V-0 package material
- ◆ No external components required
- ◆ Industry standard pinout
- ◆ Power sharing on output
- ◆ MTTF up to 1.5 million hours

## MODEL SELECTION

**A<sup>①</sup>05<sup>②</sup>05<sup>③</sup>X<sup>④</sup>S<sup>⑤</sup>-2W<sup>⑥</sup>**

- ① Product Series
- ② Input Voltage
- ③ Output Voltage
- ④ Fixed Input
- ⑤ SIP Package
- ⑥ Rated Power

## APPLICATIONS

The A-X(S)D-2W series of industrial temperature range DC/DC converters are the standard building blocks for on-board distributed power systems. They are ideally suited for providing dual rail supplies on primarily digital boards with the added benefit of galvanic isolation to reduce switching noise. All of the rated power may be drawn from a single pin provided the total load does not exceed 2 Watt. Pin compatibility with the A-X(S)D 1 watt series ensures minimal effort in upgrading distributed power systems.



**CE REACH**

MICRODC reserves the copyright

## SELECTION GUIDE

Order code	Input		Output		Efficiency (%.Typ.)	Isolation Capacitance pF	MTTF <sup>1</sup> KHrs
	Voltage(VDC)	Current (mA)	Voltage (VDC)	Current (mA)			
	Nominal	MAX					
A0505XS-2W	5	500	±5	±200	80	24	1574
A0509XS-2W	5	494	±9	±111	81	28	663
A0512XS-2W	5	488	±12	±83	82	30	338
A0515XS-2W	5	476	±15	±67	84	33	187
A1205XS-2W	12	208	±5	±200	80	35	490
A1209XS-2W	12	201	±9	±111	83	55	343
A1212XS-2W	12	198	±12	±83	84	63	229
A1215XS-2W	12	198	±15	±67	84	66	148
A1505XS-2W	15	103	±5	±200	81	41	318
A1512XS-2W	15	98	±12	±111	85	75	249
A2412XS-2W	24	97	±12	±83	86	95	183
A2415XS-2W	24	97	±15	±67	86	104	127
A4805XS-2W	48	51	±5	±200	82	45	235
A4809XS-2W	48	51	±9	±111	82	74	195
A4812XS-2W	48	49	±12	±83	85	90	152
A4815XS-2W	48	49	±15	±67	85	112	112
A0505XD-2W	5	500	±5	±200	80	24	1574
A0509XD-2W	5	494	±9	±111	81	28	663
A0512XD-2W	5	488	±12	±83	82	30	338
A0515XD-2W	5	476	±15	±67	84	33	187
A1205XD-2W	12	208	±5	±200	80	35	490
A1209XD-2W	12	201	±9	±111	83	55	343
A1212XD-2W	12	198	±12	±83	84	63	229
A1215XD-2W	12	198	±15	±67	84	66	148
A1505XD-2W	15	103	±5	±200	81	41	318
A1512XD-2W	15	98	±12	±111	85	75	249
A2412XD-2W	24	97	±12	±83	86	95	183
A2415XD-2W	24	97	±15	±67	86	104	127
A4805XD-2W	48	51	±5	±200	82	45	235
A4809XD-2W	48	51	±9	±111	82	74	195
A4812XD-2W	48	49	±12	±83	85	90	152
A4815XD-2W	48	49	±15	±67	85	112	112

1. Calculated using MIL-HDBK-217F with nominal input voltage at full load.

All specifications typical at TA=25°C, nominal input voltage and rated output current unless otherwise specified.

## Absolute Maximum Ratings

Parameter	Conditions
Lead temperature 1.5mm from case for 10 seconds	300°C
Internal power dissipation	300mW
Input voltage V <sub>i</sub> , A05 types	7V
Input voltage V <sub>in</sub> , A12 types	15V
Input voltage V <sub>in</sub> , A15 types	18V
Input voltage V <sub>in</sub> , A24 types	28V
Input voltage V <sub>in</sub> , A48 types	54V

### Input Characteristics

Parameter	Conditions	Min.	Typ.	Max.	Units
Voltage range	Continuous operation, 5V input types	4.5	5	5.5	VDC
	Continuous operation, 12V input types	10.8	12	13.2	VDC
	Continuous operation, 15V input types	13.5	15	16.5	VDC
	Continuous operation, 24V input	21.6	24	26.4	VDC
	Continuous operation, 48V input	43.2	48	52.8	VDC
Reflected ripple current	5V input types		50		mA p-p
	12V input types		70		mA p-p
	24V input types		130		mA p-p
	48V input types		200		mA p-p

### Output Specifications

Parameter	Conditions	Min.	Typ.	Max.	Units
Rated Power	TA= -40°C to 85°C			2.0	W
Voltage Set Point Accuracy	A0505XD/A0505XS	-5		7.5	%
	All other types	-5		5	%
Line regulation	High VIN to low VIN		1.0	1.2	%%
Line regulation(A24、A48)	High VIN to low VIN			1.2	%%
Load regulation	10% load to rated load, 5V output types		5	10	%
	10% load to rated load, 9V output types		3	10	%
	10% load to rated load, 12V output types		3	10	%
	10% load to rated load, 15V output types		3	10	%
Ripple & Noise	BW=DC to 20MHz, 5V output types		150	200	mV p-p
	BW=DC to 20MHz, 9V output types		100	150	mV p-p
	BW=DC to 20MHz, 12V output types		80	150	mV p-p
	BW=DC to 20MHz, 15V output types		70	150	mV p-p

### Isolation Characteristics

Parameter	Conditions	Min.	Typ.	Max.	Units
Isolation voltage	Flash tested for 1 second	1000			VDC
Resistance	Viso= 500VDC	1	10		GΩ

### General Characteristics

Parameter	Conditions	Min.	Typ.	Max.	Units
Switching frequency	5V input types		95		kHz
	12V input types		90		kHz
	15V input types		85		kHz
Switching frequency(A24、A48)	24V & 48V input types		80		kHz

### Temperature Characteristics

Parameter	Conditions	Min.	Typ.	Max.	Units
Specification	All output types	-40		85	°C
Storage		-50		130	°C
Case temperature rise above ambient	5V output types		30		°C
	12V output types		25		°C
Cooling	Free air convection				

### Temperature derating graph

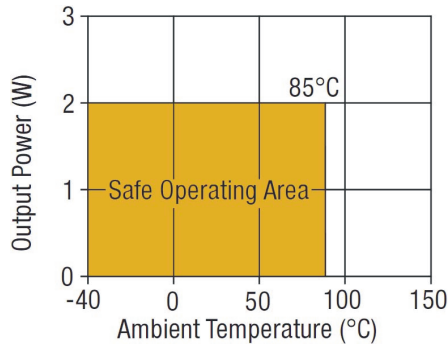

### Tolerance envelope

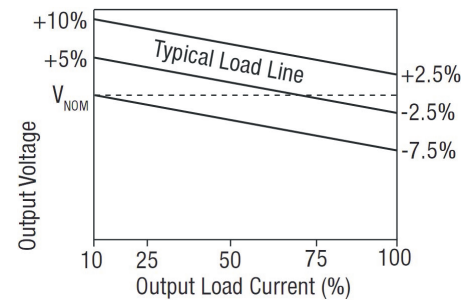

### Technical notes

#### ISOLATION VOLTAGE

"Hi Pot Test", "Flash Tested", "Withstand Voltage", "Dielectric Withstand Voltage" & " Isolation Test Voltage" are all terms that relate to the same thing, a test voltage. Applied for a specified time, across a component designed to provide electrical isolation, to verify the integrity of that isolation. Professional Power Module A series of DC/DC converters are all 100% production tested at their stated isolation voltage. This is 1KVDC for 1 second.

A question commonly asked is, "What is the continuous voltage that can be applied across the part in normal operation?"

For a part holding no specific agency approvals, such as the A series, both input and output should normally be maintained within SELV limits i.e. less than 42.4V peak, or 60VDC. The isolation test voltage represents a measure of immunity to transient voltages and the part should never be used as an element of a safety isolation system. The part could be expected to function correctly with several hundred volts offset applied continuously across the isolation barrier, but then the circuitry on both sides of the barrier must be regarded as operating at an unsafe voltage and further isolation/insulation systems must form a barrier between these circuits and any user-accessible circuitry according to safety standard requirements.

#### REPEATED HIGH-VOLTAGE ISOLATION TESTING

It is well known that repeated high-voltage isolation testing of a barrier component can actually degrade isolation capability, to a lesser or greater degree depending on materials. Construction and environment. The A series has toroidal isolation transformers, with no additional insulation between primary and secondary windings of enameled wire. While parts can be expected to withstand several times the stated test voltage, the isolation capability does depend on the wire insulation. Any material, including this enamel (typically polyurethane) is susceptible to eventual chemical degradation when subject to very high applied voltages thus implying that the number of tests should be strictly limited. We therefore strongly advise against repeated high voltage isolation testing, but if it is absolutely required, that the voltage be reduced by 20% from specified test voltage.

This consideration equally applies to agency recognized parts for better than functional isolation where the wire enamel insulation is always supplemented by a further insulation system of physical spacing or barriers.

### Technical notes

#### Output ripple reduction

By using the values of inductance and capacitance stated, the output ripple at the rated load is lowered to 5mV p-p max.

#### Component selection

Capacitor: Ceramic chip capacitors are recommended. It is required that the ESR (Equivalent Series Resistance) should be as low as possible. X7R types are recommended. The voltage rating should be at least twice (except for 15V output), the rated output voltage of the DC/DC converter.

Inductor: The rated current of the inductor should not be less than of the output of the DC/DC converter. At the rated current, the DC resistance of the inductor should be such that the voltage drop across the inductor is <2% of the rated voltage of the DC/DC converter. The SRF (Self Resonant Frequency) should be >20MHz.

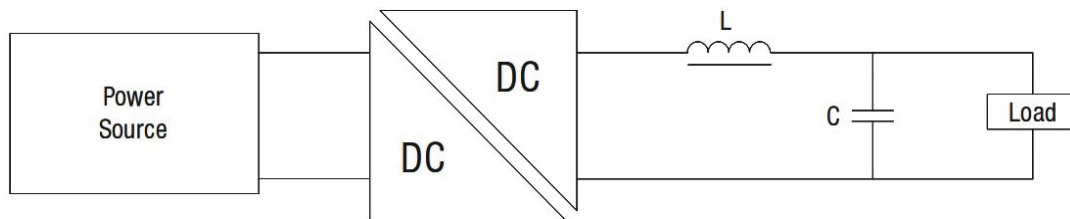

### OUTLINE DIMENSIONS & FOOTPRINT DETAILS

#### MECHANICAL DIMENSIONS

##### DIP Package

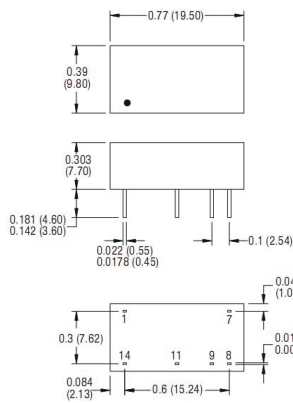

##### SIP Package

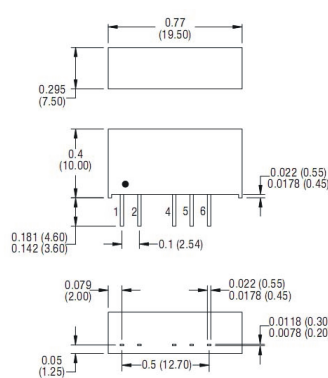

All dimensions in inches  $\pm 0.01$  (mm  $\pm 0.25$ mm). All pins on a 0.1 (2.54) pitch and within  $\pm 0.01$  (0.25) of true position.  
Weight: 2.4g (DIP) 2.1g (SIP)

#### FOOTPRINT DETAILS

##### -14 PIN DIP

Pin	Function
1	-Vin
7	NC
8	0V
9	+Vout
11	-Vout
14	+Vin

##### -7 PIN SIP

Pin	Function
1	+Vin
2	-Vin
4	-Vout
5	0V
6	+Vout

NC - Not available for electrical connection.

**Specifications can be changed any time without notice.**

**No parallel connection or plug and play.**

Note:

- The load shouldn't be less than 10%, otherwise ripple will increase dramatically.
- Operation under 10% load will not damage the converter; However, they may not meet all specification listed.
- All specifications measured at  $T_a=25^\circ\text{C}$ , humidity < 75%, nominal input voltage and rated output load unless otherwise specified.
- In this datasheet, all the test methods of indications are based on corporate standards.

#### Recommended footprint details

##### 14 PIN DIP Package

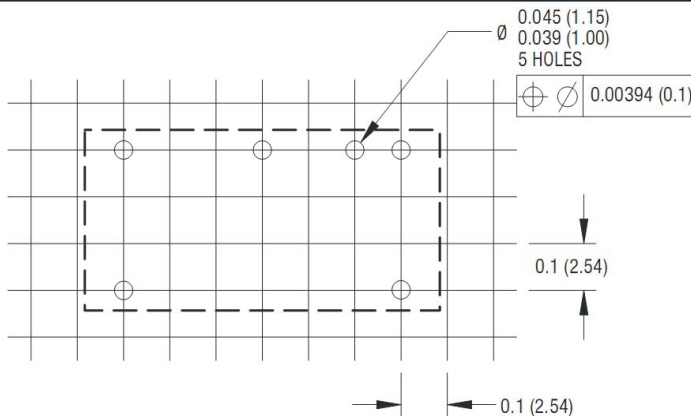

##### 7 PIN SIP Package

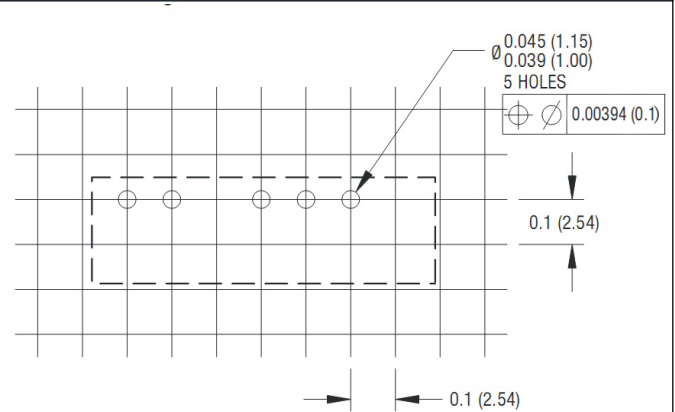

#### TUBE OUTLINE DIMENSIONS

##### 14 PIN DIP Tube

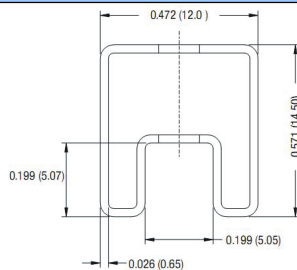

##### 7 PIN SIP Tube

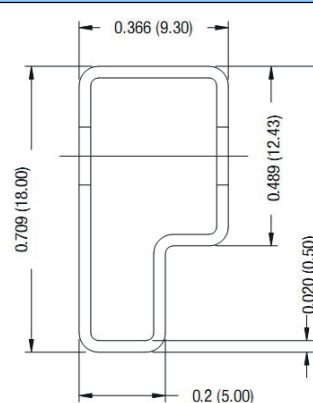

Unless otherwise stated all dimensions in inches (mm)  $\pm 0.5$ mm.

Tube length (14 Pin DIP) : 20.47 (520mm  $\pm 2$ mm).

Tube length (7 Pin SIP) : 20.47 (520mm  $\pm 2$ mm).

Tube Quantity :25

### MICRODC

Professional Power Module

Microdc Professional Power Module, Inc.

Tel:0086-20-86000646 E-mail:tech@microdc.cn

Website:http://www.microdc.cn

Microdc Professional Power module, Inc. makes no representation that the use of its products in the circuits described herein, or the use of other technical information contained herein, will not infringe upon existing or future patent rights. Specifications are subject to change without notice.

©2010 Microdc Professional Power Module, Inc. Guangzhou



#### RoHS COMPLIANT INFORMATION

This series is compatible with RoHS soldering systems with a peak wave solder temperature of 300°C for 10 seconds. The pin termination finish on the SIP package type is Tin Plate, Hot Dipped over Matte Tin with Nickel Preplate. The DIP types are Matte Tin over Nickel Preplate. Both types in this series are backward compatible with Sn/Pb soldering systems.



#### REACH COMPLIANT INFORMATION

This series has proven that this product does not contain harmful chemicals, it also has harmful chemical substances through the registration, inspection and approval.