

5.7-inch 320×240 Dots

L□□BL6 Series

5.7-inch, high-brightness, high-contrast LCD module with built-in power circuit.

LCD Modules for Mobile Information Devices

LCD Modules with CCFL Backlight

www.DataSheet4U.com



Product number

Mode	Product number
B/W N-B	LRUBL616XA

The product number in the left is inscribed on typical models only.

Mechanical characteristics

Dimensions (165.5×112.3×8.5mm) / Weight (165g)

Screen size

14.6cm / 5.7inch

Dimensions

Unit : mm

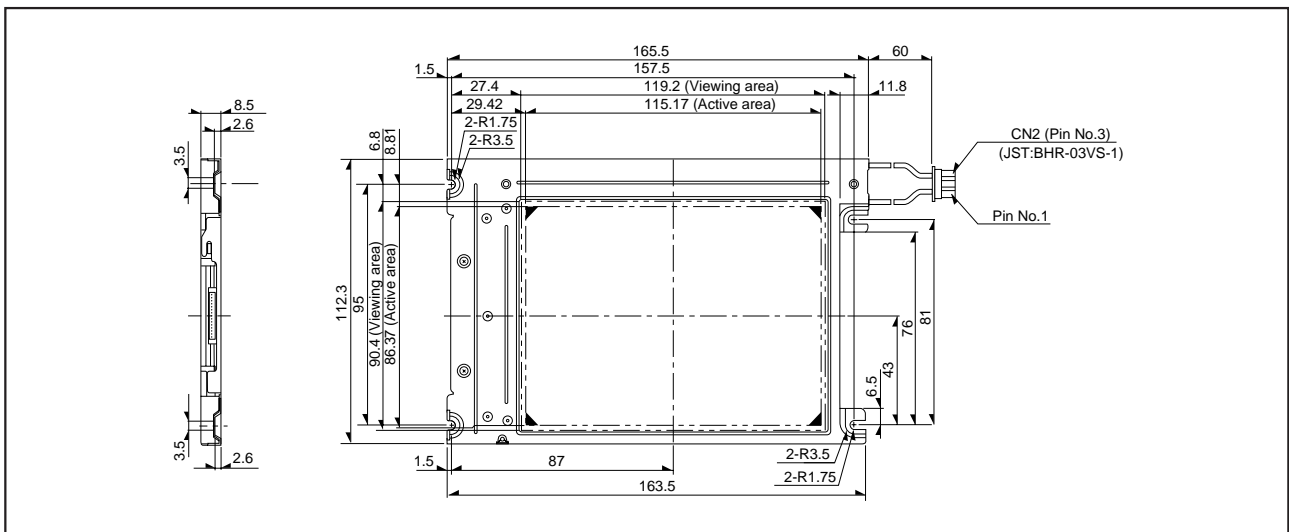

For details, see P.8
www.DataSheet4U.com

Mask details

Unit : mm

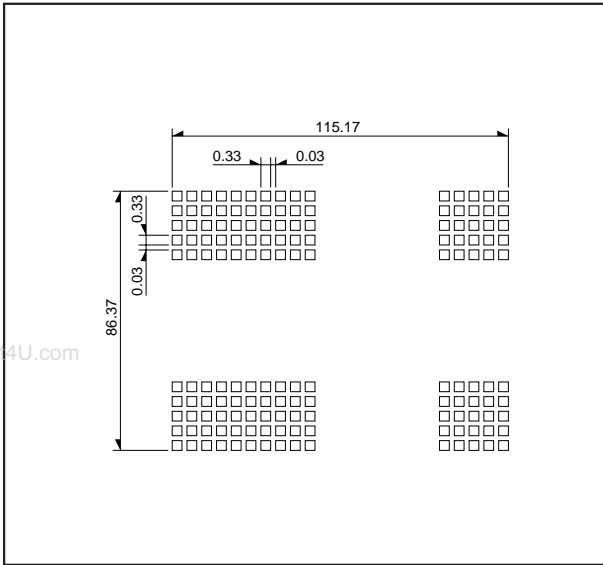

Block diagram

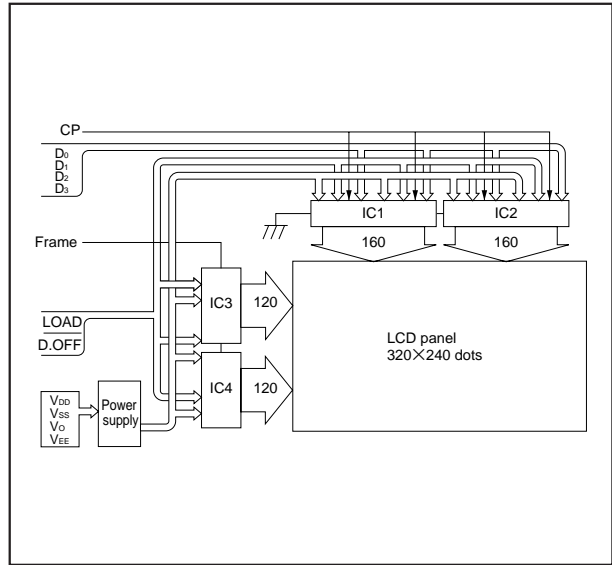

Optical characteristic at 25°C

Items		STN-N / B (Transmissive)			Unit
		min.	typ.	max.	
Response time	τ rise	—	370	450	ms
	τ fall	—	180	250	ms
Viewing angle	Top-bottom	Top15, Bottom30	—	—	Degree
	Right-left	± 30	—	—	Degree
Contrast ratio		—	8	—	—
Surface brightness		—	180	—	cd / m ²

Terminals

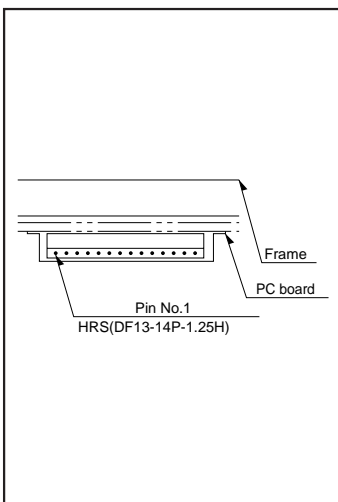

Interface pin connections

Pin No.	Symbol	Function	
1	FRAME	Frame start signal (Data signal from the common driver shift register)	
2	NC	Non-connection	
3	LOAD	1) The signal for latching the shift register data of 1 line 2) The common driver data shift signal	
4	CP	Clock pulse for segment shift register	
5	D.OFF	H : Display ON L : Display OFF	
6 to 9	D ₀ to D ₃	Data input signal	
10	V _{DD}	Supply Voltage	Logic supply voltage
11	V _{SS}		GND
12	V _{EE}		Load power source for liquid crystal driver
13	V _O	Power supply voltage for contrast adjustment	
14	FG	Frame ground	

Recommendable driving voltage

25°C	V _O =24.9V
------	-----------------------

Table of Products

Table of Absolute Maximum Ratings

Number of dots		320×240 dots		640×240 dots	640×480 dots	320×RGB×240 dots
Product number		LSUBL617XA	LRUBL616XA	LSUGC206XA	LRUGB608XA	LFUBL605XA
Supply voltage for logic V _{DD} -V _{SS} (V)	min.	- 0.3				
	max.	6				
Supply voltage for driving LCD (V)	min.	0			※6	0
	max.	30			※30	32
Input voltage V _I (V)	min.	- 0.3				
	max.	V _{DD} +0.3				
Storage temperature T _{st} (°C)	min.	- 20				
	max.	70			60	

Note

※ V_{DD}-V_{EE} : Negative power supply

Table of Electrical Characteristics

Number of dots		320×240 dots		640×240 dots	640×480 dots	320×RGB×240 dots
Product number		LSUBL617XA	LRUBL616XA	LSUGC206XA	LRUGB608XA	LFUBL605XA
Input high level voltage V _{IH} (V)	min.	0.8V _{DD}				
	max.	V _{DD}				
Input low level voltage V _{IL} (V)	min.	0				
	max.	0.2V _{DD}				
Power supply current (mA)	I _{DD} (typ.)	3		6	19	2.4
	I _{EE} (typ.)	4.5		10	15	8
	Condition	V _{DD} =5V V _O =24.9V V _{EE} =30V		V _{DD} =5V V _{EE} =23.0V	V _{DD} =5V V _{EE} =-18.5V	V _{DD} =5V V _{EE} =30V
Example for power supply See P.10		B		C	A	D

Power Supply Examples

A

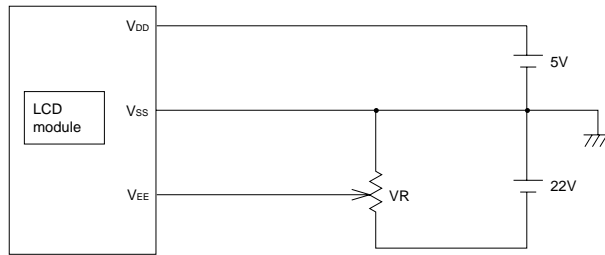

B

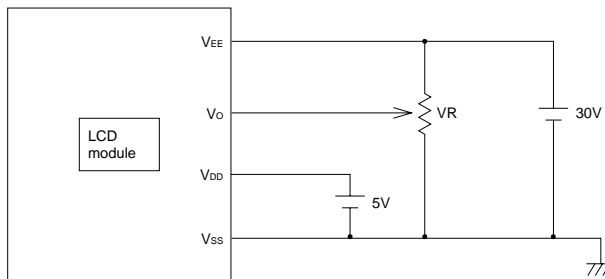

C

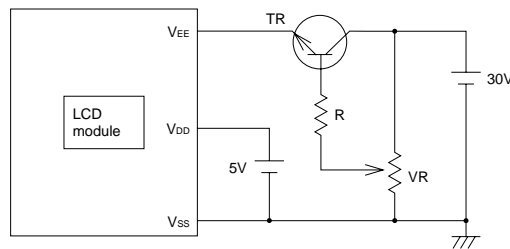

D

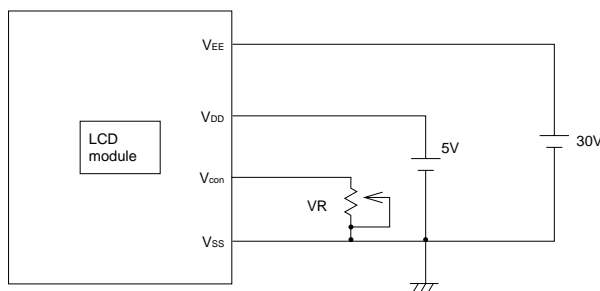

LCD Modules for Mobile Information Devices

LCD Modules with CCFL Backlight

www.DataSheet4U.com