

Matched GaAs SPDT Switch

DC - 2 GHz

SW-331, SW-333

V 2.00

Features

- Miniature Ceramic Package
- Fast Switching Speed, 7 ns Typical
- Ultra Low DC Power Consumption

Guaranteed Specifications¹ (-55°C to +85°C)

Frequency Range	DC - 2.0 GHz	SW-331	SW-333	
Insertion Loss	DC - 2.0 GHz	1.4	1.4	dB Max
	DC - 1.0 GHz	1.0	1.0	dB Max
	DC - 0.5 GHz	0.9	0.9	dB Max
VSWR	DC - 2.0 GHz	2.0:1	2.0:1	Max
	DC - 1.0 GHz	1.4:1	1.4:1	Max
	DC - 0.5 GHz	1.3:1	1.3:1	Max
Isolation	DC - 2.0 GHz	40	30	dB Min
	DC - 1.0 GHz	47	35	dB Min
	DC - 0.5 GHz	52	40	dB Min

Operating Characteristics

Impedance 50 Ohms Nominal

Switching Characteristics

T_{rise}, T_{fall} (10% to 90%)	7 ns Typ
T_{on}, T_{off} (50% CTL to 90%/10% RF)	10 ns Typ
Transients (In-Band)	25 mV Typ

Input Power for 1 dB Compression

0.5 - 2.0 GHz	+30 dBm Typ
0.05 GHz	+25 dBm Typ

Intermodulation Intercept Pt. (for two-tone input power up to +13 dBm)

Intercept Points	IP ₂	IP ₃	
0.5 - 2.0 GHz	+65	+46	dBm Typ
0.05 GHz	+60	+40	dBm Typ

Control Voltages (Complementary Logic)

V _{in Low}	0 to -0.2V @ 20 μA Max
V _{in High}	-5V @ 25 μA Typ to -8V @ 300 μA Max

1. All specifications apply with 50 ohm impedance connected to all RF ports with 0 and -5 Vdc control voltages.
2. Contact the factory for standard or custom screening requirements.

Ordering Information

Part Number	Package
SW-331 PIN	Ceramic
SW-333 PIN	Ceramic

SW-331 (CR-2)

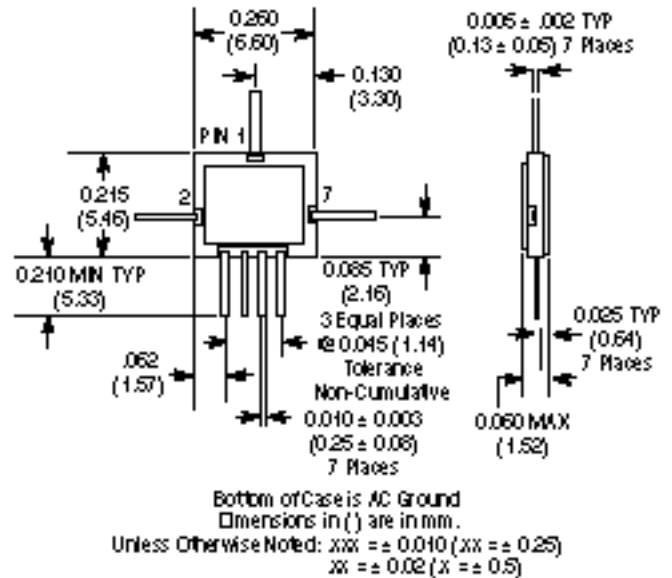

SW-333 (CR-3)

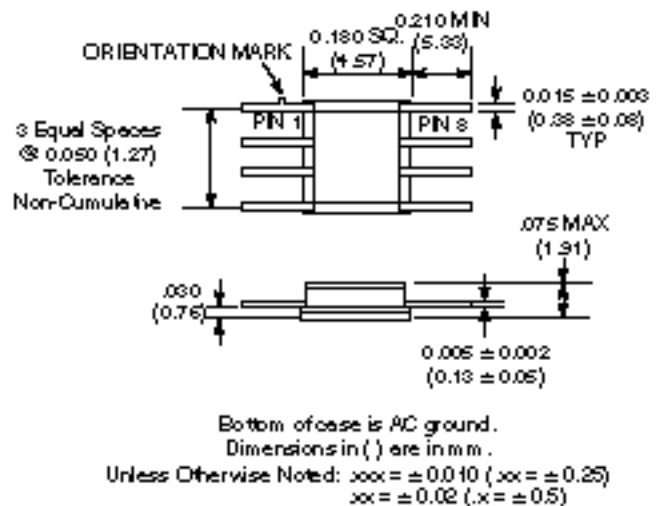

Absolute Maximum Ratings

Parameter	Absolute Maximum ¹
Max. Input Power	
0.05 GHz	+27 dBm
0.5 – 2.0 GHz	+34 dBm
Control Voltage	+5V, -8.5V
Operating Temperature	-40°C to +85°C
Storage Temperature	-65°C to +150°C

1. Operation of this device above any one of these parameters may cause permanent damage.

Typical Performance

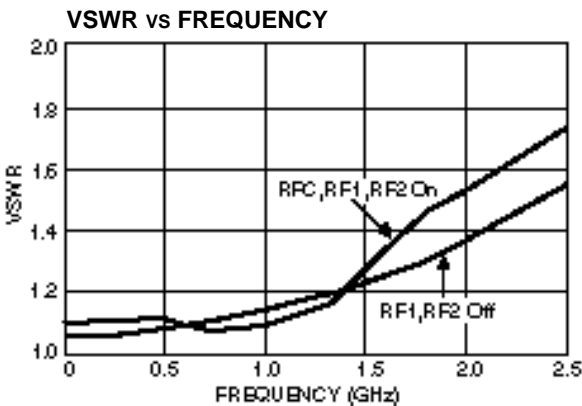
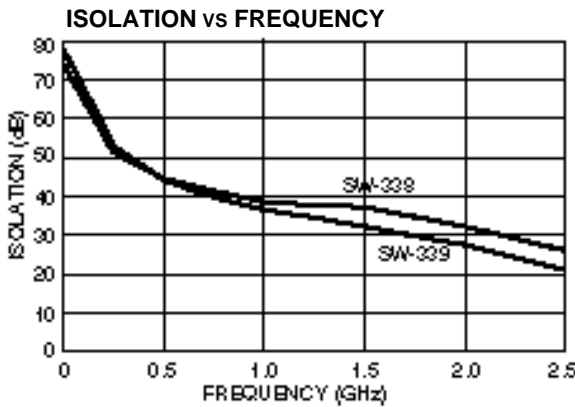
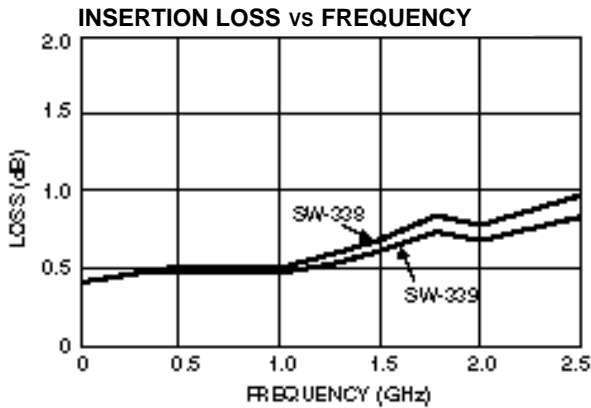

Functional Schematics

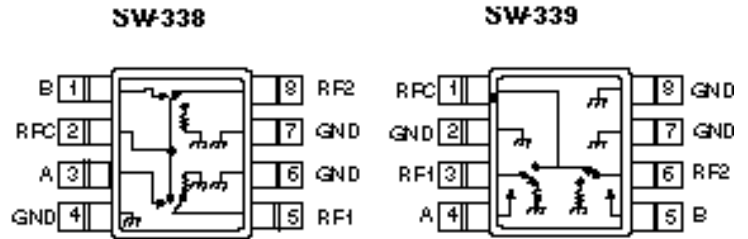

Pin Configuration

SW-338		SW-339	
Pin No.	Description	Pin No.	Description
1	B	1	RFCCommon
2	RFCCommon	2	GND
3	A	3	RF1
4	GND	4	A
5	RF1	5	B
6	GND	6	RF2
7	GND	7	GND
8	RF2	8	GND

Truth Table

Control Inputs		Condition of Switch RFCCommon to Each RF Port	
A	B	RF1	RF2
1	0	ON	OFF
0	1	OFF	ON

'0' - 0 to -0.2V @ 20µA max.
'1' - 5V @ 30µA Typ to -8V @ 720µA max.

Electrical Schematic

