

Features

3.2 (L) x 2.8 (W) x 1.9 (H) mm Size
 Flat-top Type
 InGaAlP LED
 Low Drive Current, High Intensity Emission
 High Operating Temperature
 Reflow Soldering is possible
 Standard embossed taping 8 mm Pitch : T09 (1000 pcs/reel)

Applications

Automotive Use
 Message Signboard
 Backlight

Series Line-Up

Part Number	Color	Material
TLGU1100	Ultra Bright Yellow Green	InGaAlP
TLOU1100	Ultra Bright Orange	InGaAlP
TLPGU1100	Ultra Pure Green	InGaAlP
TLSU1100	Ultra High Efficiency Red	InGaAlP
TLYU1100	Ultra Bright Yellow	InGaAlP

Maximum Ratings (Ta=25°C)

Part Number	Forward Current I _F	Reverse Voltage V _R	Power Dissipation P _D	Operating Temperature T _{opr}	Storage Temperature T _{stg}
TLGU1100	30	4	84.00	-40 ~ 100	-40 ~ 100
TLOU1100	30	4	72.00	-40 ~ 100	-40 ~ 100
TLPGU1100	30	4	84.00	-40 ~ 100	-40 ~ 100
TLSU1100	30	4	72.00	-40 ~ 100	-40 ~ 100
TLYU1100	30	4	75.00	-40 ~ 100	-40 ~ 100
Unit	mA	V	mW	°C	°C

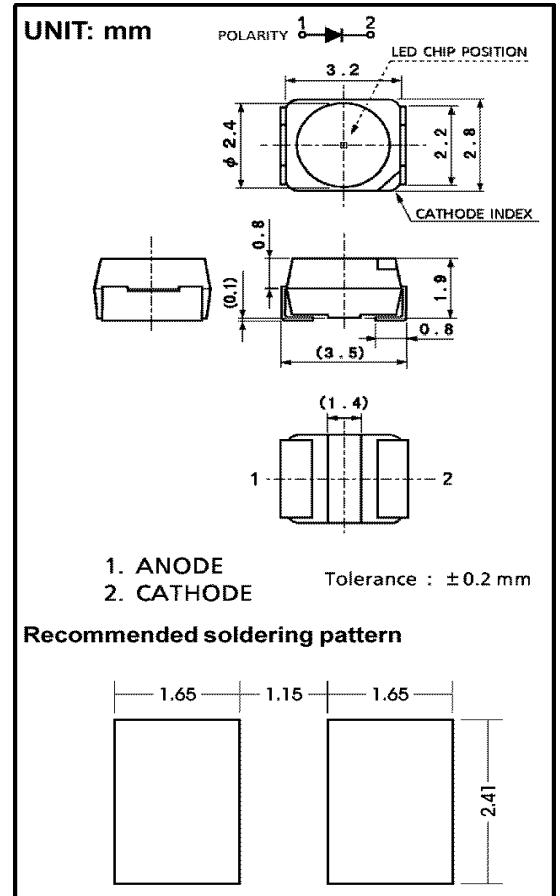

Electrical and Optical Characteristics (Ta=25°C)

Part Number	PWL nm λ_P	Material	View Angle $2\theta_{1/2}$	Luminous Intensity I_v				Forward Voltage V_F				Rev Current I_R	
				min.	typ.	max.	IF@	min.	typ.	max.	IF@	max.	VR@
TLGU1100	574	InGaAIP	120°	15.30	45.00	–	20mA	–	2.30	2.80	20mA	50	4V
TLOU1100	612	InGaAIP	120°	47.60	100.00	–	20mA	–	2.00	2.40	20mA	50	4V
TLPGU1100	562	InGaAIP	120°	4.76	12.00	–	20mA	–	2.30	2.80	20mA	50	4V
TLSU1100	636	InGaAIP	120°	27.20	80.00	–	20mA	–	2.00	2.40	20mA	50	4V
TLYU1100	590	InGaAIP	120°	15.30	50.00	–	20mA	–	2.10	2.50	20mA	50	4V
–	nm	–	deg	mcd			–	V			–	μA	–

NOTICE:

- TOSHIBA is continually working to improve the quality and reliability of its products. Nevertheless, semiconductor devices in general can malfunction or fail due to their inherent electrical sensitivity and vulnerability to physical stress. It is the responsibility of the buyer, when utilizing TOSHIBA products, to comply with the standards of safety in making a safe design for the entire system, and to avoid situations in which a malfunction or failure of such TOSHIBA products could cause loss of human life, bodily injury or damage to property.
- In developing your designs, please ensure that TOSHIBA products are used within specified operating ranges as set forth in the most recent TOSHIBA products specifications. Also, please keep in mind the precautions and conditions set forth in the "Handling Guide for Semiconductor Devices," or "TOSHIBA Semiconductor Reliability Handbook" etc..
- The TOSHIBA products listed in this document are intended for usage in general electronics applications (computer, personal equipment, office equipment, measuring equipment, industrial robotics, domestic appliances, etc.). These TOSHIBA products are neither intended nor warranted for usage in equipment that requires extraordinarily high quality and/or reliability or a malfunction or failure of which may cause loss of human life or bodily injury ("Unintended Usage"). Unintended Usage include atomic energy control instruments, airplane or spaceship instruments, transportation instruments, traffic signal instruments, combustion control instruments, medical instruments, all types of safety devices, etc.. Unintended Usage of TOSHIBA products listed in this document shall be made at the customer's own risk.
- Gallium arsenide (GaAs) is a substance used in the products described in this document. GaAs dust and fumes are toxic. Do not break, cut or pulverize the product, or use chemicals to dissolve them. When disposing of the products, follow the appropriate regulations. Do not dispose of the products with other industrial waste or with domestic garbage.
- The information contained herein is presented only as a guide for the applications of our products. No responsibility is assumed by TOSHIBA CORPORATION for any infringements of intellectual property or other rights of the third parties which may result from its use. No license is granted by implication or otherwise under any intellectual property or other rights of TOSHIBA CORPORATION or others.
- The information contained herein is subject to change without notice.

Company Headquarters
 120 Broadway
 Menands, New York 12204
 Toll Free: 800.984.5337
 Fax: 518.432.7454



Web: www.marktechopto.com | Email: info@marktechopto.com

West Coast Sales Office
 950 South Coast Drive, Suite 265
 Costa Mesa, California 92626
 Toll Free: 800.984.5337
 Fax: 714.850.9314

TLGU1100 Graphs

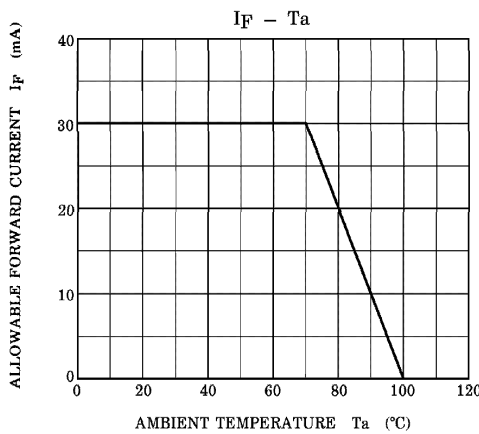
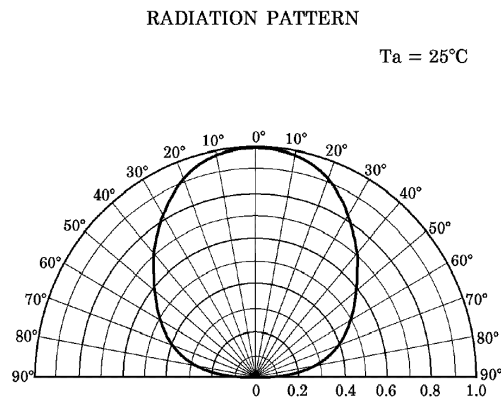
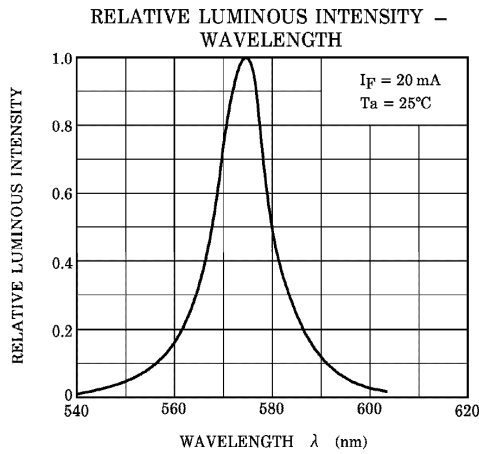
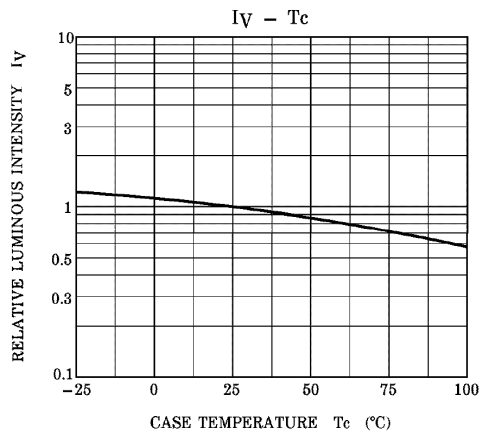
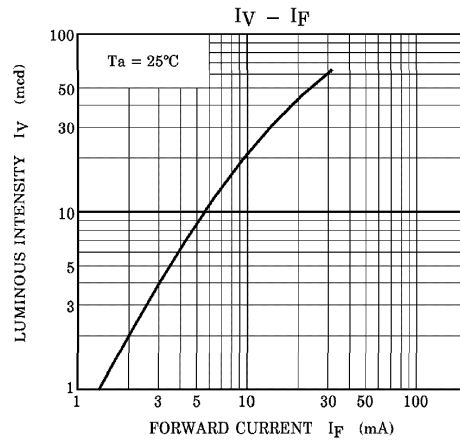
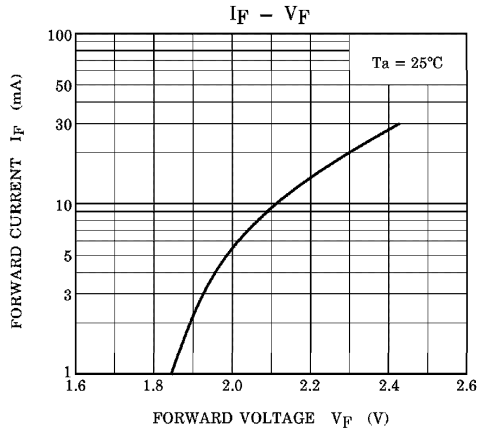

TLOU1100 Graphs

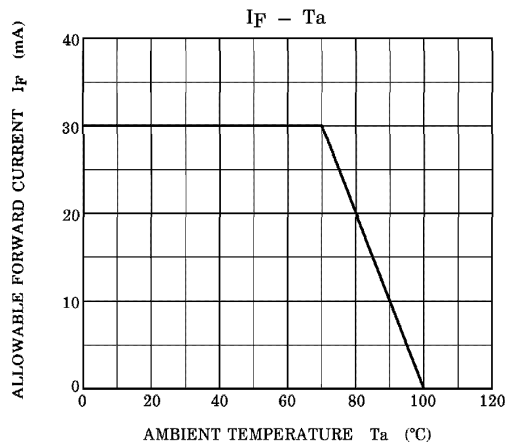
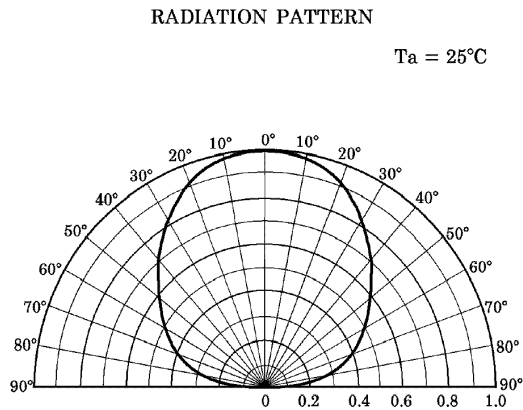
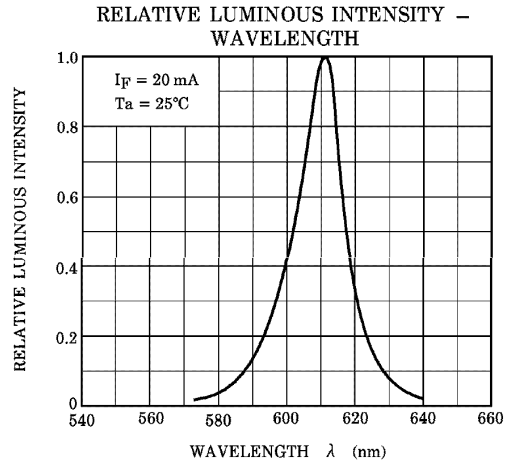
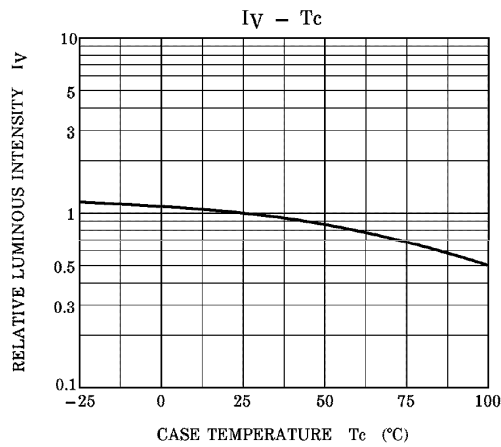
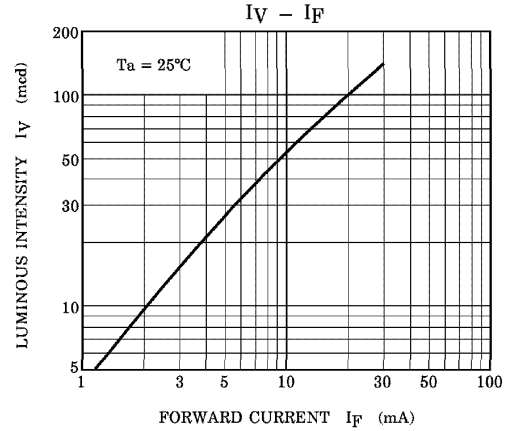
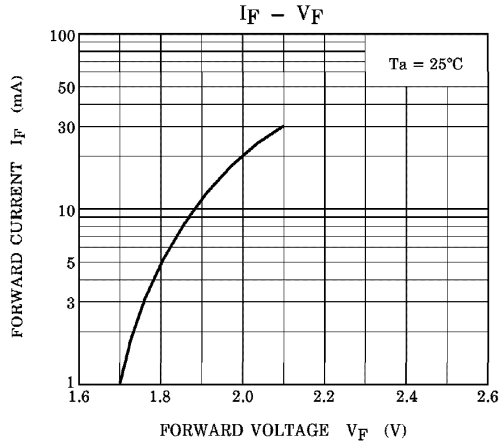

TLPGU1100 Graphs

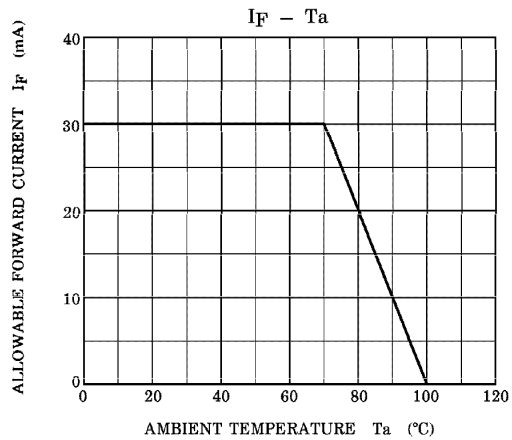
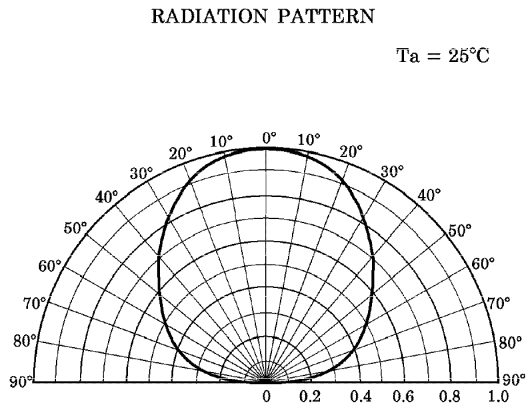
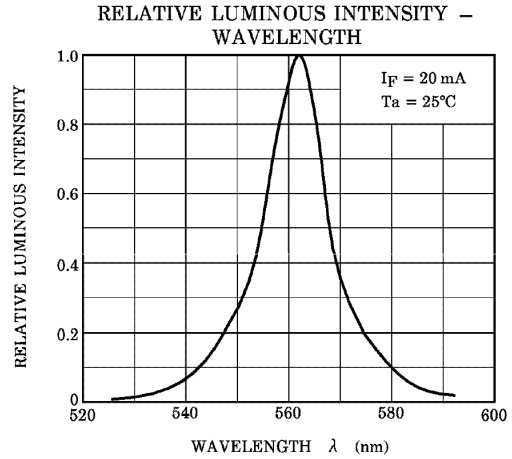
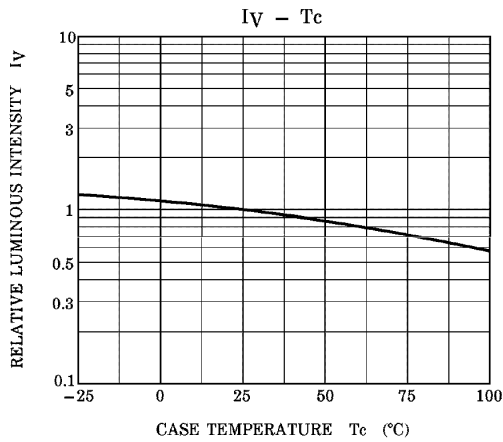
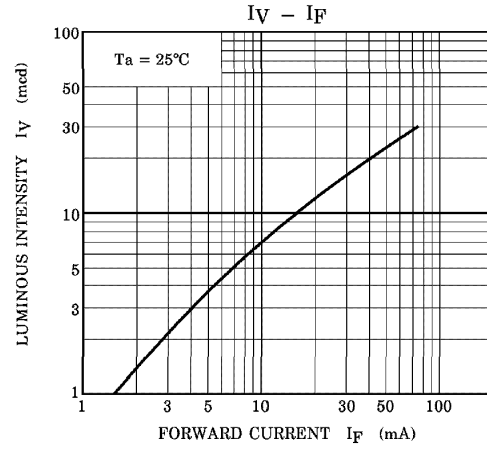
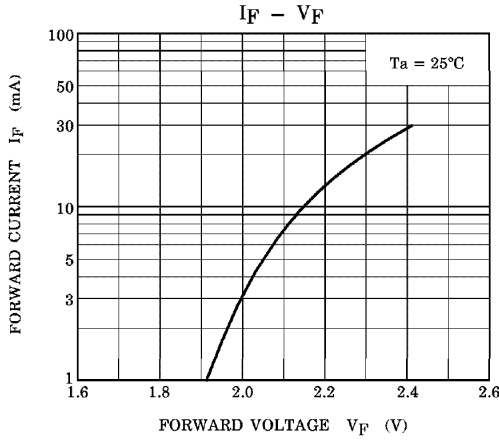

TLSU1100 Graphs

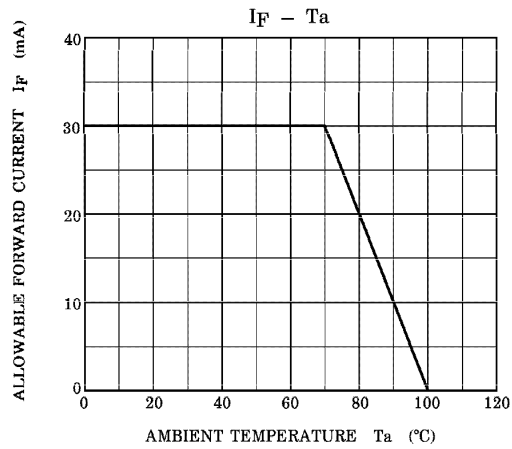
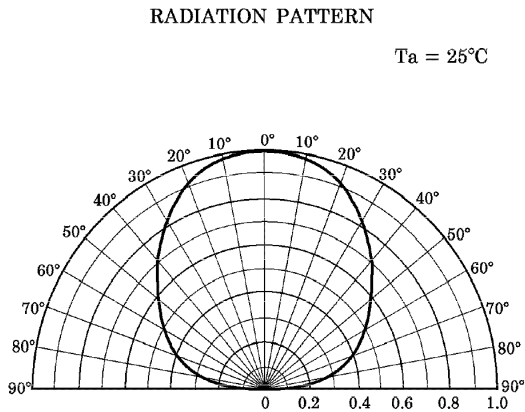
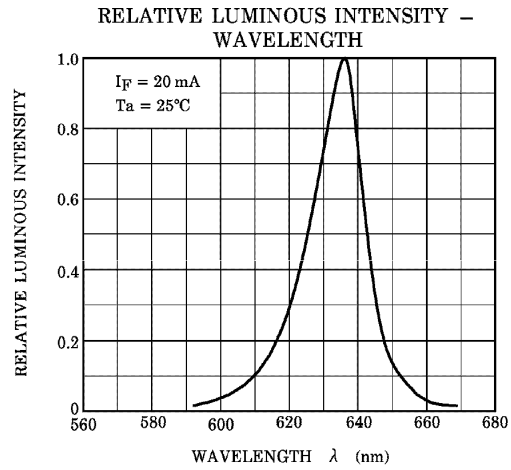
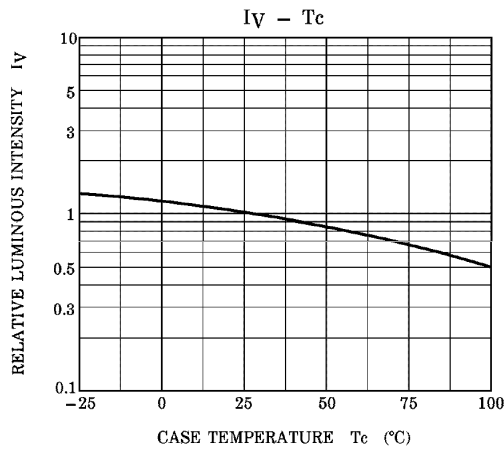
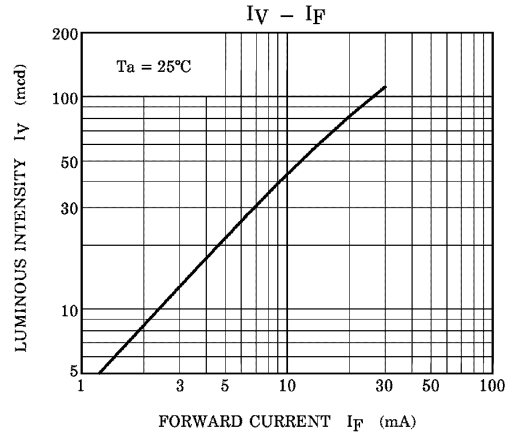
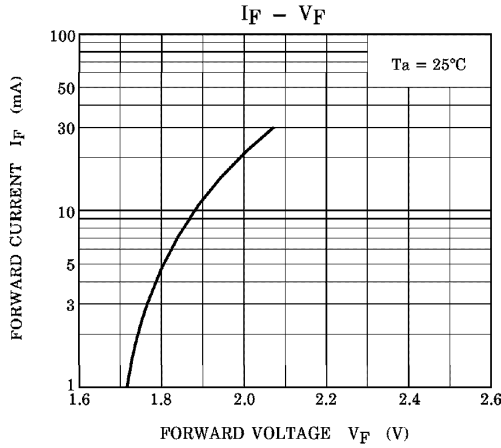

TLYU1100 Graphs

