

High-side current sense amplifier plus signal conditioning amplifier

Features

- Independent supply and input common-mode voltages
- Wide common-mode operating range: 2.8 to 30 V
- Wide common-mode surviving range: -16 to 60 V (reversed battery and load-dump conditions)
- Low current consumption: $I_{CC} \text{ max} = 420 \mu\text{A}$
- Output amplifier for tailor-made signal conditioning
- -40 to 125° C operating temperature range
- 4 kV ESD protection

Applications

- Battery chargers
- Automotive current monitoring
- Notebook computers
- DC motor control
- Photovoltaic systems
- Precision current sources
- Uninterruptible power supplies
- High-end power supplies

Description

The TSC102 measures a small differential voltage on a high-side shunt resistor and translates it into a ground-referenced output voltage.

The device's wide input common-mode voltage range, low quiescent current and tiny TSSOP8 packaging enable use in a wide variety of applications (also available in SO-8 package).

The input common-mode and power supply voltages are independent. The common-mode voltage can range from 2.8 to 30 V in operating conditions.

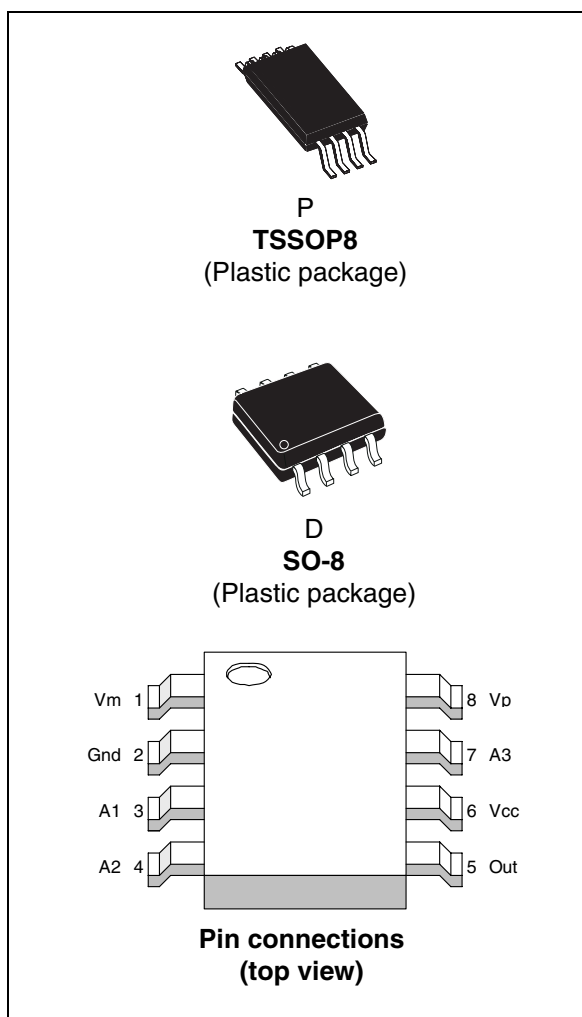

The TSC102 is rugged against abnormal conditions on the input pins: Vp and Vm can withstand up to 60 V in case of voltage spikes, as little as -16 V in case of reversed battery, and up to 4 kV in case of electrostatic discharge.

In addition to the current sensing amplifier, the TSC102 offers a fully accessible amplifier for output signal conditioning.

The device's overall current consumption is lower than 420 μA .

Contents

- 1 Application schematic and pin description 3**
- 2 Absolute maximum ratings and operating conditions 4**
- 3 Electrical characteristics 5**
- 4 Electrical characteristics curves: current sense amplifier 8**
- 5 Electrical characteristics curves: signal conditioning amplifier 11**
- 6 Parameter definitions 12**
 - 6.1 Common-mode rejection ratio (CMR) 12
 - 6.2 Supply voltage rejection ratio (SVR) 12
 - 6.3 Gain (A_v) and input offset voltage (V_{os}) 12
 - 6.4 Output voltage drift versus temperature 13
 - 6.5 Output voltage accuracy 14
- 7 Application information 16**
- 8 Package information 19**
 - 8.1 SO-8 package information 20
 - 8.2 TSSOP-8 package information 21
- 9 Ordering information 22**
- 10 Revision history 23**

1 Application schematic and pin description

The TSC102 high-side current sense amplifier features a 2.8 to 30 V input common-mode range that is independent of the supply voltage. The main advantage of this feature is that it allows high-side current sensing at voltages much greater than the supply voltage (V_{CC}).

Figure 1. Application schematics

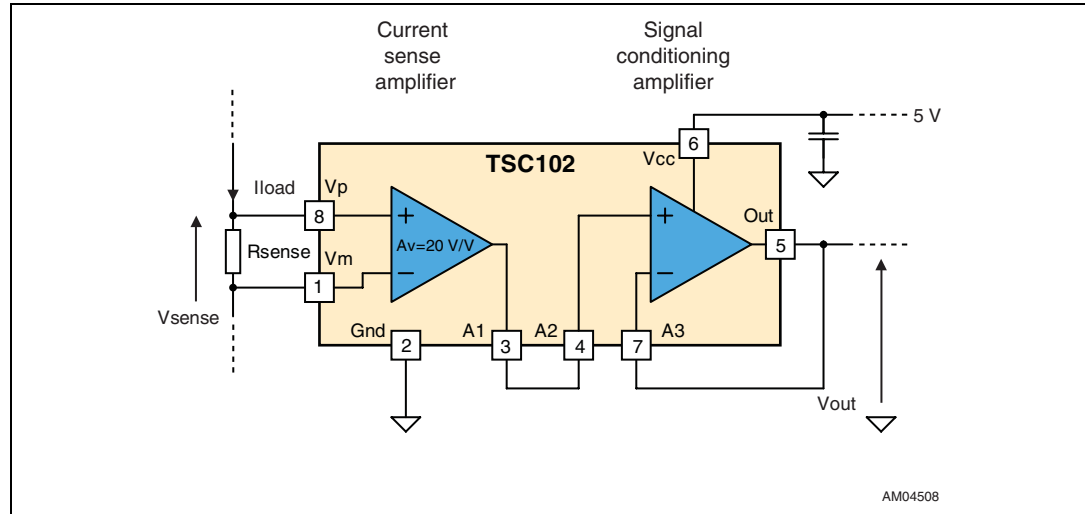

[Table 1](#) describes the function of each pin. Their position is shown in the illustration on the cover page and in [Figure 1](#) above.

Table 1. Pin description

Symbol	Type	Function
Out	Analog output	Out voltage is proportional to the magnitude of the sense voltage $V_p - V_m$.
Gnd	Power supply	Ground line.
V_{CC}	Power supply	Positive power supply line.
V_p	Analog input	Connection for the external sense resistor. The measured current enters the shunt on the V_p side.
V_m	Analog input	Connection for the external sense resistor. The measured current exits the shunt on the V_m side.
A1	Analog input	Connection to current sensing amplifier output.
A2	Analog input	Connection to signal conditioning amplifier non-inverting input.
A3	Analog input	Connection to signal conditioning amplifier inverting input.

2 Absolute maximum ratings and operating conditions

Table 2. Absolute maximum ratings

Symbol	Parameter	Value	Unit
V_{id}	Input pins differential voltage ($V_p - V_m$)	± 20	V
V_i	Current sensing input pin voltages (V_p and V_m) ⁽¹⁾	-16 to 60	V
V_1	Voltage for pins A1, A2, A3, Out, V_{cc} ⁽¹⁾	-0.3 to 7	V
T_{stg}	Storage temperature	-55 to 150	°C
T_j	Maximum junction temperature	150	°C
R_{thja}	TSSOP8 thermal resistance junction to ambient	120	°C/W
	SO-8 thermal resistance junction to ambient	125	°C/W
ESD	HBM: human body model for V_m and V_p pins ⁽²⁾	4	kV
	HBM: human body model ⁽³⁾	2.5	kV
	MM: machine model ⁽⁴⁾	200	V
	CDM: charged device model ⁽⁵⁾	1.5	kV

1. These voltage values are measured with respect to the GND pin.
2. Human body model for V_m and V_p : a 100 pF capacitor is charged to the specified voltage, then discharged through a 1.5 kΩ resistor between the V_p or V_m pin and Gnd while the other pins are floating.
3. Human body model: a 100 pF capacitor is charged to the specified voltage, then discharged through a 1.5 kΩ resistor between two pins of the device. This is done for all couples of connected pin combinations while the other pins are floating.
4. Machine model: a 200 pF capacitor is charged to the specified voltage, then discharged directly between two pins of the device with no external series resistor (internal resistor < 5 Ω). This is done for all couples of connected pin combinations while the other pins are floating.
5. Charged device model: all pins plus package are charged together to the specified voltage and then discharged directly to ground.

Table 3. Operating conditions

Symbol	Parameter	Value	Unit
V_{CC}	DC supply voltage from T_{min} to T_{max}	3.5 to 5.5	V
T_{oper}	Operational temperature range (T_{min} to T_{max})	-40 to 125	°C
V_{icm}	Common mode voltage range (V_m pin voltage)	2.8 to 30	V

3 Electrical characteristics

Unless otherwise specified, the electrical characteristics given in the following tables have been measured under the following test conditions.

- $T_{amb} = 25^{\circ} \text{C}$, $V_{CC} = 5 \text{ V}$, $V_{sense} = V_p - V_m = 50 \text{ mV}$, $V_m = 12 \text{ V}$.
- No load on Out pin.
- Signal conditioning amplifier used as a buffer (pin A3 connected to pin Out and pin A1 connected to pin A2).

Table 4. Supply

Symbol	Parameter	Test conditions	Min.	Typ.	Max.	Unit
I_{CC}	Total supply current	$V_{sense} = 0 \text{ V}$, pin A1 open, pin A2 shorted to Gnd $T_{min} < T_{amb} < T_{max}$		240	420	μA
I_{CC1}	Total supply current	$V_{sense} = 50 \text{ mV}$, pin A1 connected to pin A2 $T_{min} < T_{amb} < T_{max}$		420	700	μA

Table 5. Current sensing amplifier input stage

Symbol	Parameter	Test conditions	Min.	Typ.	Max.	Unit
DC CMR1	DC common mode rejection Variation of V_{a1} versus V_{icm} referred to input ⁽¹⁾	$2.8 \text{ V} < V_m < 30 \text{ V}$ $-40^{\circ} \text{ C} < T_{amb} < 150^{\circ} \text{ C}$	90	100		dB
AC CMR1	AC common mode rejection Variation of V_{a1} versus V_{icm} referred to input (peak-to-peak voltage variation)	$2.8 \text{ V} < V_m < 30 \text{ V}$ 1 kHz sine wave		75		dB
		$2.8 \text{ V} < V_m < 30 \text{ V}$ 10 kHz sine wave		60		dB
SVR1	Supply voltage rejection Variation of V_{a1} versus V_{CC} ⁽²⁾	$3.5 \text{ V} < V_{CC} < 5.5 \text{ V}$ $-40^{\circ} \text{ C} < T_{amb} < 125^{\circ} \text{ C}$	85	90		dB
V_{os}	Input offset voltage ⁽³⁾	$T_{amb} = 25^{\circ} \text{ C}$ $-40^{\circ} \text{ C} < T_{amb} < 125^{\circ} \text{ C}$			± 1.5 ± 2.3	mV
dV_{os}/dT	Input offset drift versus T	$-40^{\circ} \text{ C} < T_{amb} < 125^{\circ} \text{ C}$		± 3	± 8	$\mu\text{V}/^{\circ}\text{C}$
I_{lk}	Input leakage current	$V_{CC} = 0 \text{ V}$ $T_{min} < T_{amb} < T_{max}$			1	μA
I_{ib}	Input bias current	$V_{sense} = 0 \text{ V}$ $T_{min} < T_{amb} < T_{max}$		5	7	μA

1. See [Chapter 6: Parameter definitions on page 12](#) for the definition of CMR.

2. See [Chapter 6](#) for the definition of SVR.

3. See [Chapter 6](#) for the definition of V_{os} .

Table 6. Current sensing amplifier output stage

Symbol	Parameter	Test conditions	Min.	Typ.	Max.	Unit
A_v	Gain (variation of V_{a1} versus V_{sense})			20		V/V
V_{oh1}	A1 node high-level saturation voltage $V_{oh1} = V_{cc} - V_{a1}$	$V_{sense} = 1\text{ V}$ $I_{a1} = 1\text{ mA}$ $-40^\circ\text{ C} < T_{amb} < 125^\circ\text{ C}$		85	185	mV
V_{ol1}	A1 node low-level saturation voltage	$V_{sense} = -1\text{ V}$ $I_{a1} = 1\text{ mA}$ $-40^\circ\text{ C} < T_{amb} < 125^\circ\text{ C}$		75	165	mV
I_{sc1}	Short-circuit current	A1 connected to V_{CC} or Gnd	10	30		mA
$\Delta V_{a1}/\Delta T$	Output voltage drift versus $T^{(1)}$	$T_{min} < T_{amb} < T_{max}$			± 400	ppm/ $^\circ\text{C}$
$\Delta V_{a1}/\Delta I_{a1}$	Output stage load regulation	$-5\text{ mA} < I_{a1} < +5\text{ mA}$ I_{a1} sink or source current		0.4	± 2	mV/mA
ΔV_{a1}	Total output voltage accuracy ⁽²⁾	$V_{sense} = 50\text{ mV}$ $T_{amb} = 25^\circ\text{ C}$ $T_{min} < T_{amb} < T_{max}$			± 2.5 ± 4	%
ΔV_{a1}	Total output voltage accuracy ⁽²⁾	$V_{sense} = 100\text{ mV}$ $T_{amb} = 25^\circ\text{ C}$ $T_{min} < T_{amb} < T_{max}$			± 2.5 ± 4	%
ΔV_{a1}	Total output voltage accuracy ⁽²⁾	$V_{sense} = 20\text{ mV}$ $T_{amb} = 25^\circ\text{ C}$ $T_{min} < T_{amb} < T_{max}$			± 8 ± 10	%
ΔV_{a1}	Total output voltage accuracy ⁽²⁾	$V_{sense} = 10\text{ mV}$ $T_{amb} = 25^\circ\text{ C}$ $T_{min} < T_{amb} < T_{max}$			± 13 ± 16	%

1. See [Chapter 6: Parameter definitions on page 12](#) for the definition of output voltage drift versus temperature.
2. Output voltage accuracy is the difference with the expected theoretical output voltage $V_{a1-th} = A_v * V_{sense}$. See [Chapter 6](#) for a more detailed definition.

Table 7. Current sensing amplifier frequency response

Symbol	Parameter	Test conditions	Min.	Typ.	Max.	Unit
t_s	V_{a1} settling to 1% final value	$V_{sense} = 10\text{ mV to }100\text{ mV}$, $C_{load} = 47\text{ pF}$		7		μs
SR	Slew rate	$V_{sense} = 10\text{ mV to }100\text{ mV}$	0.2	0.4		V/ μs
BW	3 dB bandwidth	$C_{load} = 47\text{ pF}$		800		kHz

Table 8. Current sensing amplifier noise

Symbol	Parameter	Test conditions	Min.	Typ.	Max.	Unit
e_N	Equivalent input noise voltage	$f = 1\text{ kHz}$		50		nV/ $\sqrt{\text{Hz}}$

Table 9. Signal conditioning amplifier

Symbol	Parameter	Test conditions	Min.	Typ.	Max.	Unit
V_{icm}	Common mode voltage range	$T_{min} < T_{amb} < T_{max}$	0		V_{CC}	
V_{IO}	Input offset voltage	$V_{a2} = 1\text{ V}$ $T_{amb} = 25^\circ\text{ C}$ $-40^\circ\text{ C} < T_{amb} < 150^\circ\text{ C}$			± 3.5 ± 4.5	mV
ΔV_{IO}	Input offset voltage drift	$T_{min} < T_{amb} < T_{max}$		5		$\mu\text{V}/^\circ\text{C}$
I_{ib}	Input bias current	$V_{a2} = V_{a3} = V_{CC}/2$		10		pA
V_{oh2}	Output high-level saturation voltage ($V_{oh2} = V_{CC} - V_{out}$)	$V_{a2} = 1\text{ V}$ $V_{a3} = 0\text{ V}$ $I_{out} = 1\text{ mA}$ $-40^\circ\text{ C} < T_{amb} < 125^\circ\text{ C}$		85	185	mV
V_{ol2}	Output low-level saturation voltage	$V_{a2} = 0\text{ V}$ $V_{a3} = 1\text{ V}$ $I_{out} = 1\text{ mA}$ $-40^\circ\text{ C} < T_{amb} < 125^\circ\text{ C}$		75	165	mV
I_{sc2}	Short-circuit current	Out connected to V_{CC} or Gnd	12	30		mA
$\Delta V_{out}/\Delta I_{out}$	Output stage load regulation	$-10\text{ mA} < I_{out} < +10\text{ mA}$ $V_{a2} = 1\text{ V}$ I_{out} sink or source current			300	$\mu\text{V}/\text{mA}$
CMR2	DC common mode rejection Variation of V_{IO} versus V_{icm}	$T_{min} < T_{amb} < T_{max}$ $0\text{ V} < V_{a2} < 3\text{ V}$ $0\text{ V} < V_{a2} < 5\text{ V}$	70 60	95 80		dB
SVR2	Supply voltage rejection Variation of V_{IO} versus V_{CC}	$3.5\text{ V} < V_{CC} < 5.5\text{ V}$ $V_{a2} = 1\text{ V}$ $-40^\circ\text{ C} < T_{amb} < 125^\circ\text{ C}$	85	105		dB
GBP	Gain bandwidth product	$R_L = 10\text{ k}\Omega$ $C_{load} = 100\text{ pF}$, $f = 100\text{ kHz}$		1		MHz
PM	Phase margin	$R_L = 10\text{ k}\Omega$ $C_{load} = 100\text{ pF}$		65		deg
SR	Slew rate	$R_L = 10\text{ k}\Omega$ $C_{load} = 100\text{ pF}$ $V_{a2} = 0.5\text{ V}$ to 4.5 V A3 connected to OUT (follower configuration) Slew rate measured from 10% to 90% of V_{out} step	0.2	0.4		$\text{V}/\mu\text{s}$

4 Electrical characteristics curves: current sense amplifier

Unless otherwise specified, the test conditions for the following curves are:

- $T_{amb} = 25^{\circ}C$, $V_{CC} = 5V$, $V_{sense} = V_p - V_m = 50mV$, $V_m = 12V$.
- no load on Out pin.
- signal conditioning amplifier used as a buffer (pin A3 connected to pin Out and pin A1 connected to pin A2).

Figure 2. Output voltage vs. Vsense

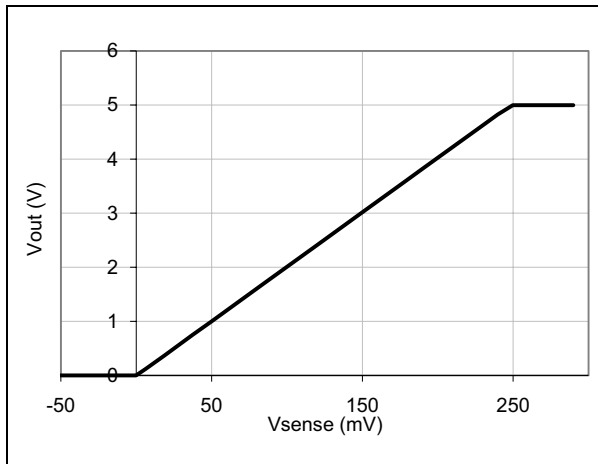

Figure 3. A1 pin voltage accuracy vs. Vsense

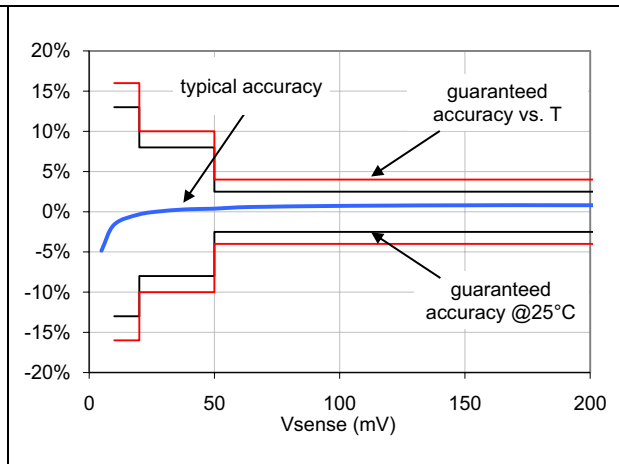

Figure 4. Supply current vs. supply voltage

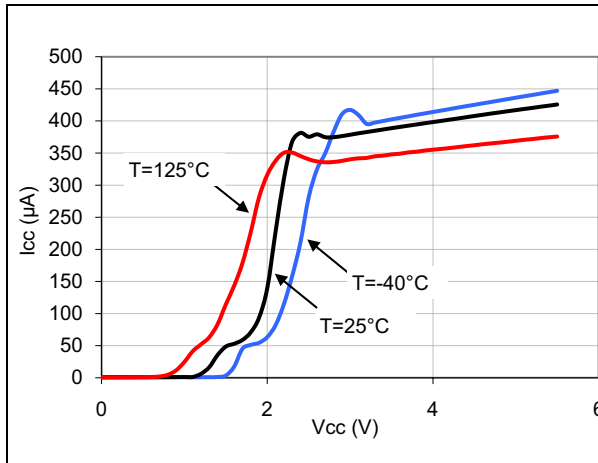

Figure 5. Supply current vs. Vsense

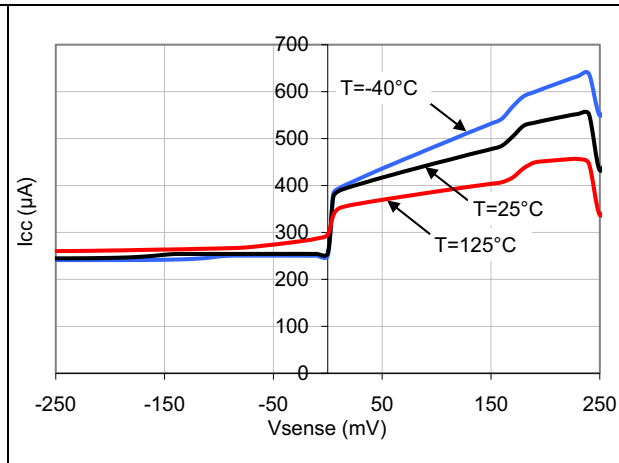

Figure 6. Vp pin input bias current vs. Vsense

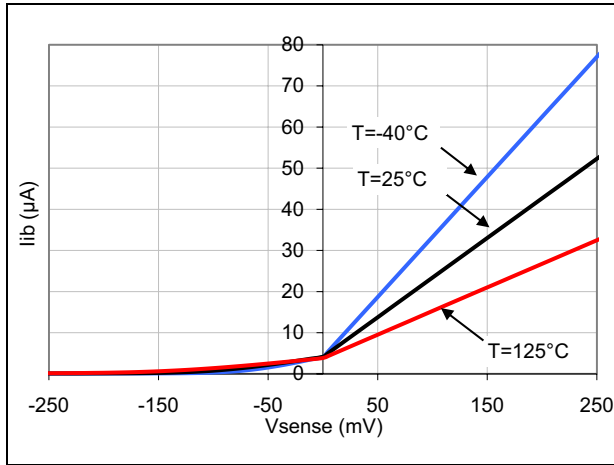

Figure 7. Vm pin input bias current vs. Vsense

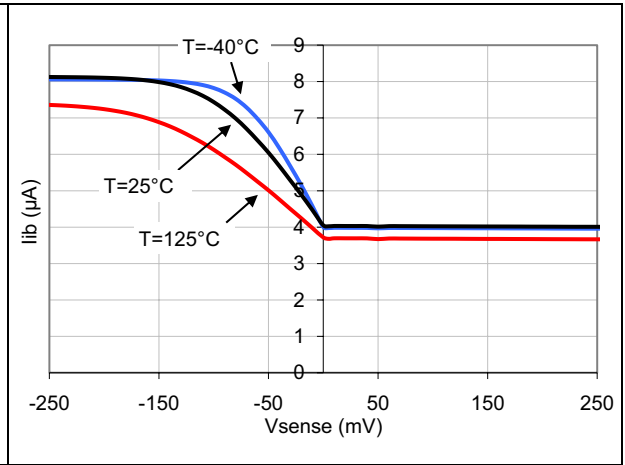

Figure 8. Output stage low-state saturation voltage versus output current (Vsense = -1 V)

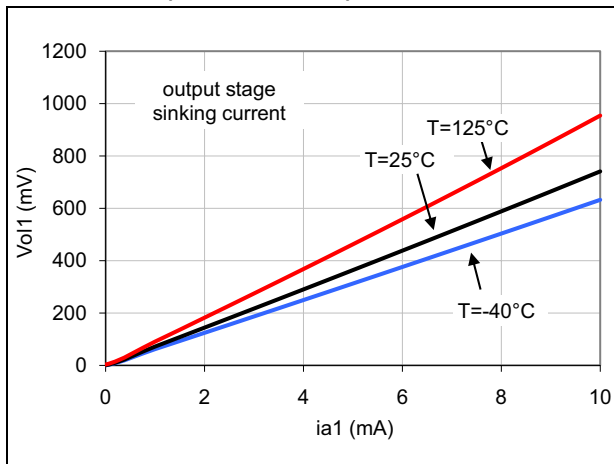

Figure 9. Output stage high-state saturation voltage versus output current (Vsense = +1 V)

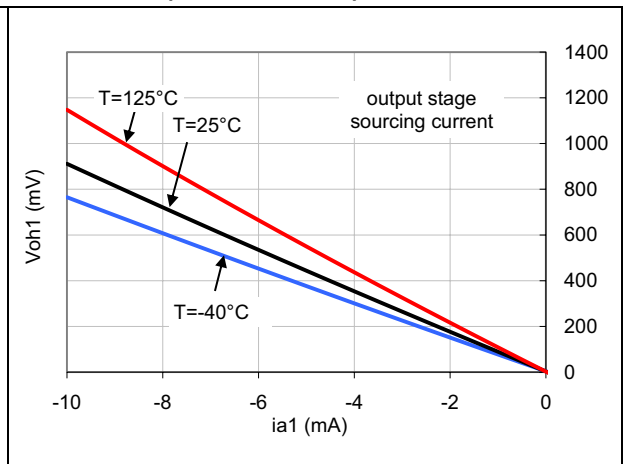

Figure 10. Output stage load regulation

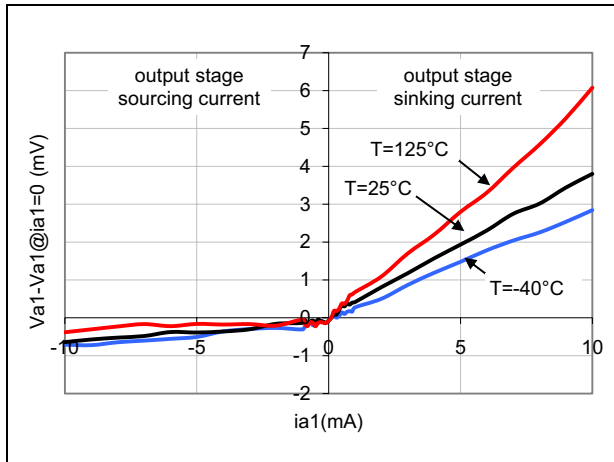

Figure 11. Step response

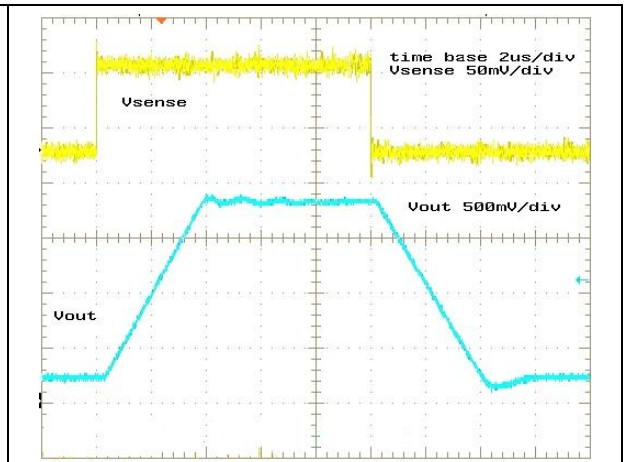

Figure 12. Bode diagram

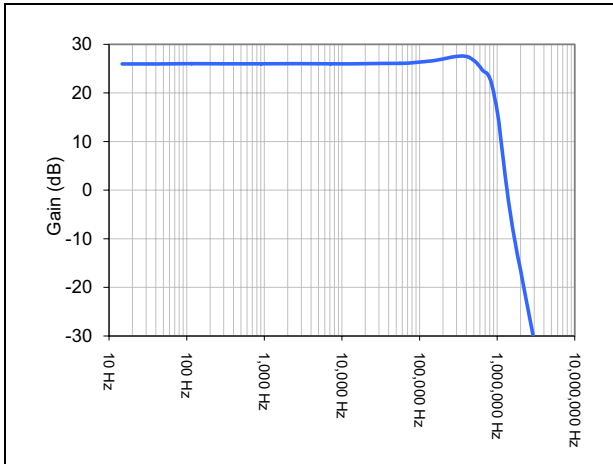
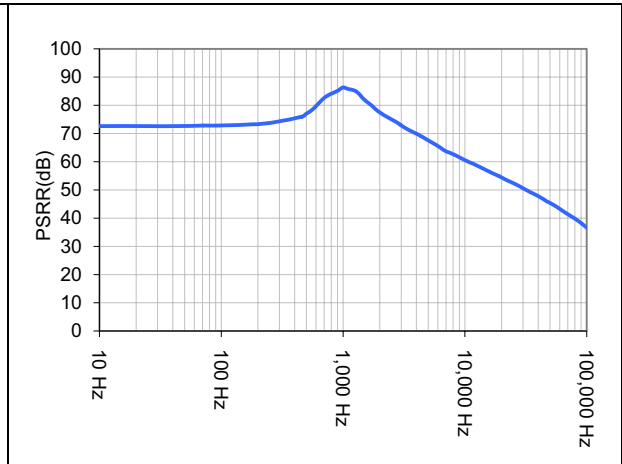

Figure 13. Power supply rejection ratio



5 Electrical characteristics curves: signal conditioning amplifier

Unless otherwise specified, the test conditions for the following curves are:

- $T_{amb} = 25^{\circ}C$, $V_{CC} = 5V$
- no load on Out.
- signal conditioning amplifier tested as standalone amplifier.

Figure 14. Input offset voltage versus input common-mode voltage

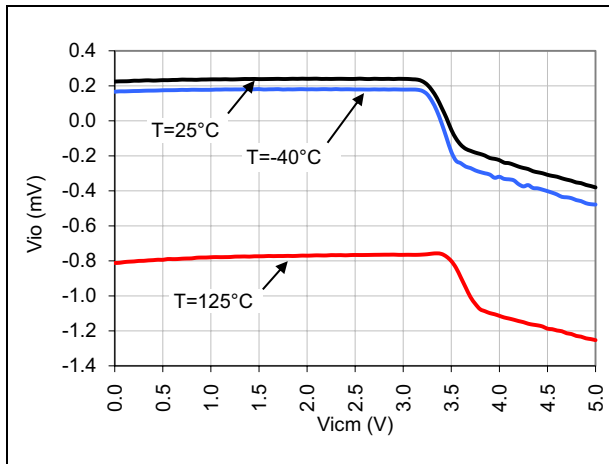

Figure 15. Input offset voltage versus supply voltage ($V_{cm} = V_{CC}/2$)

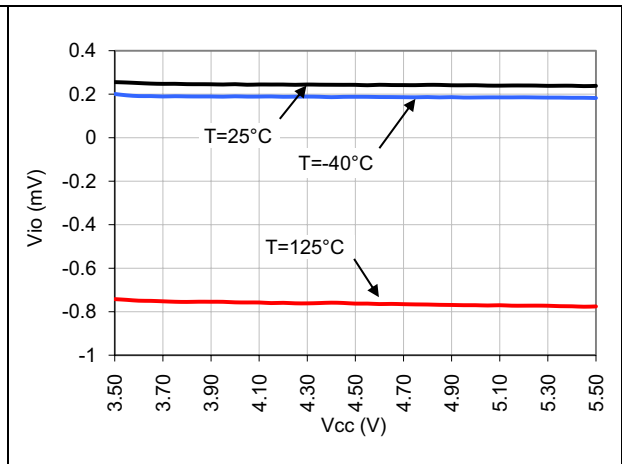

Figure 16. Output current versus output voltage

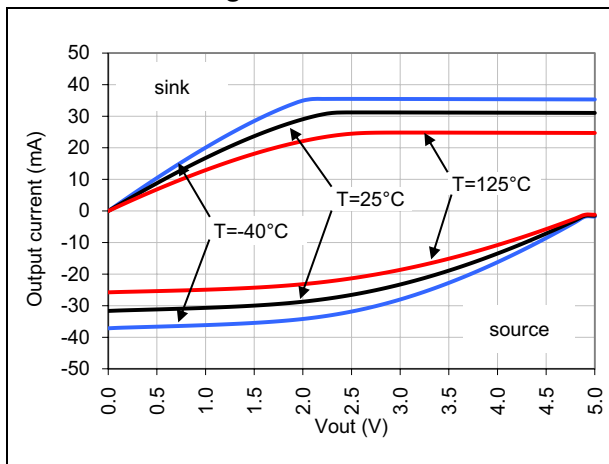
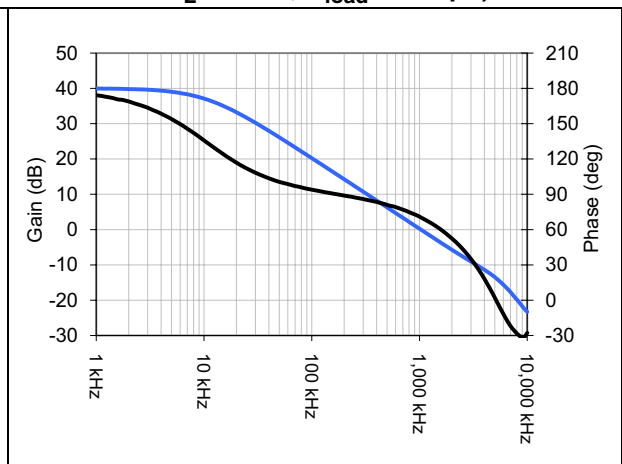

Figure 17. Bode diagram ($V_{out} = V_{CC}/2$, $R_L = 10k\Omega$, $C_{load} = 100pF$)



6 Parameter definitions

6.1 Common-mode rejection ratio (CMR)

The common-mode rejection ratio (CMR) measures the ability of the current sensing amplifier to reject any DC voltage applied on both inputs V_p and V_m . The CMR is referred back to the input so that its effect can be compared with the applied differential signal. The CMR is defined by the formula:

$$\text{CMR} = -20 \cdot \log \frac{\Delta V_{a1}}{\Delta V_{icm} \cdot A_v}$$

6.2 Supply voltage rejection ratio (SVR)

The supply voltage rejection ratio (SVR) measures the ability of the current sensing amplifier to reject any variation of the supply voltage V_{CC} . The SVR is referred back to the input so that its effect can be compared with the applied differential signal. The SVR is defined by the formula:

$$\text{SVR} = -20 \cdot \log \frac{\Delta V_{a1}}{\Delta V_{cc} \cdot A_v}$$

6.3 Gain (A_v) and input offset voltage (V_{os})

The input offset voltage is defined as the intersection between the linear regression of the V_{a1} versus V_{sense} curve with the X-axis (see [Figure 18](#)). If V_{a11} is the output voltage with $V_{sense} = V_{sense1} = 50$ mV and V_{a12} is the output voltage with $V_{sense} = V_{sense2} = 5$ mV, then V_{os} can be calculated with the formula:

$$V_{os} = V_{sense1} - \left(\frac{V_{sense1} - V_{sense2}}{V_{a11} - V_{a12}} \cdot V_{out1} \right)$$

The amplification gain A_v is defined as the ratio between the output voltage and the input differential voltage.

$$A_v = \frac{V_{out}}{V_{sense}}$$

Figure 18. V_{a1} versus V_{sense} characteristics: detail for low V_{sense} values

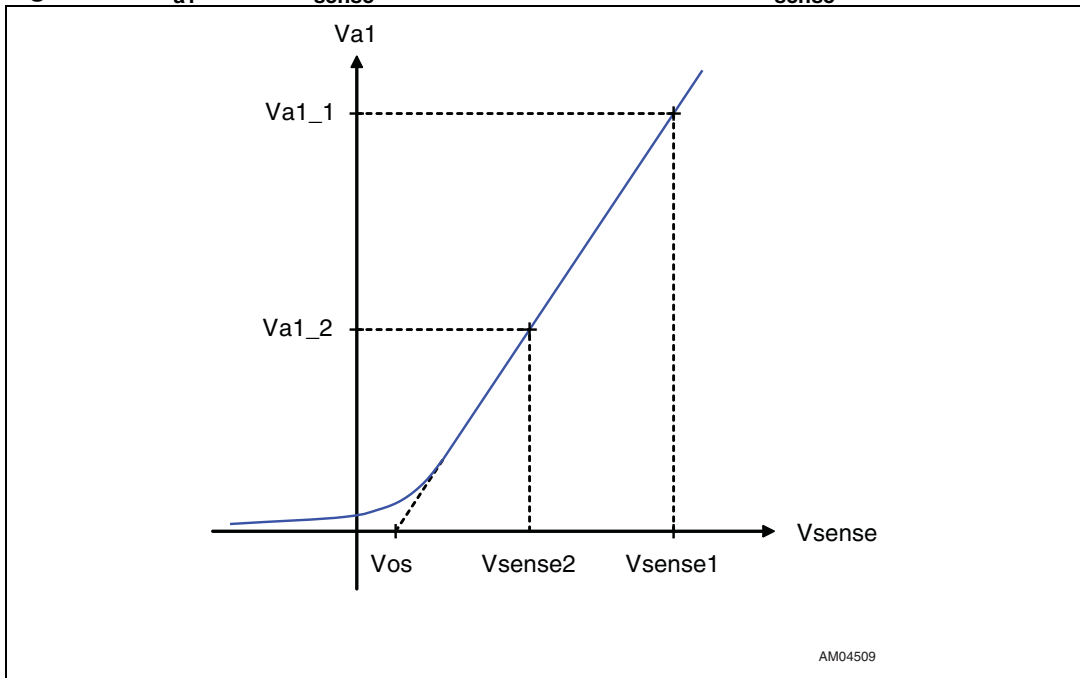

6.4 Output voltage drift versus temperature

The output voltage drift versus temperature is defined as the maximum variation of V_{a1} with respect to its value at 25° C, over the temperature range. It is calculated as follows:

$$\frac{\Delta V_{a1}}{\Delta T} = \max \frac{V_{a1}(T_{amb}) - V_{a1}(25^\circ C)}{T_{amb} - 25^\circ C}$$

with $T_{min} < T_{amb} < T_{max}$.

Figure 19 on page 14 provides a graphical definition of the output voltage drift versus temperature. On this chart V_{a1} is always within the area defined by the maximum and minimum variation of V_{a1} versus T, and T = 25° C is considered to be the reference.

Figure 19. Output voltage drift versus temperature

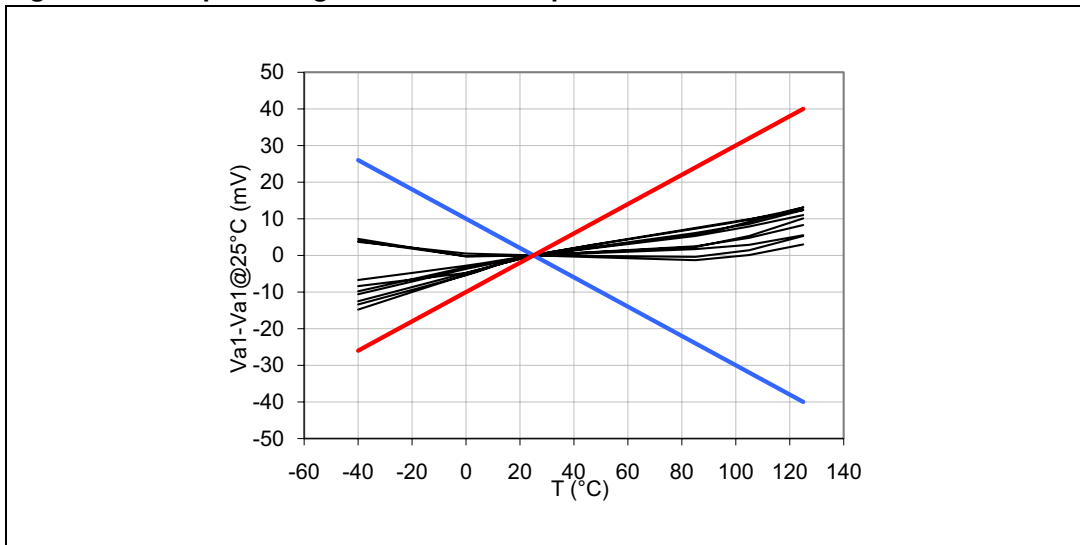

6.5 Output voltage accuracy

The output voltage accuracy is the difference between the actual output voltage and the theoretical output voltage. Ideally, the current sensing output voltage should be equal to the input differential voltage multiplied by the theoretical gain, as in the following formula.

$$V_{a1-th} = A_v \cdot V_{sense}$$

The actual value is very slightly different, mainly due to the effects of the input offset voltage V_{os} and the non-linearity.

Figure 20. V_{a1} vs. V_{sense} theoretical and actual characteristics

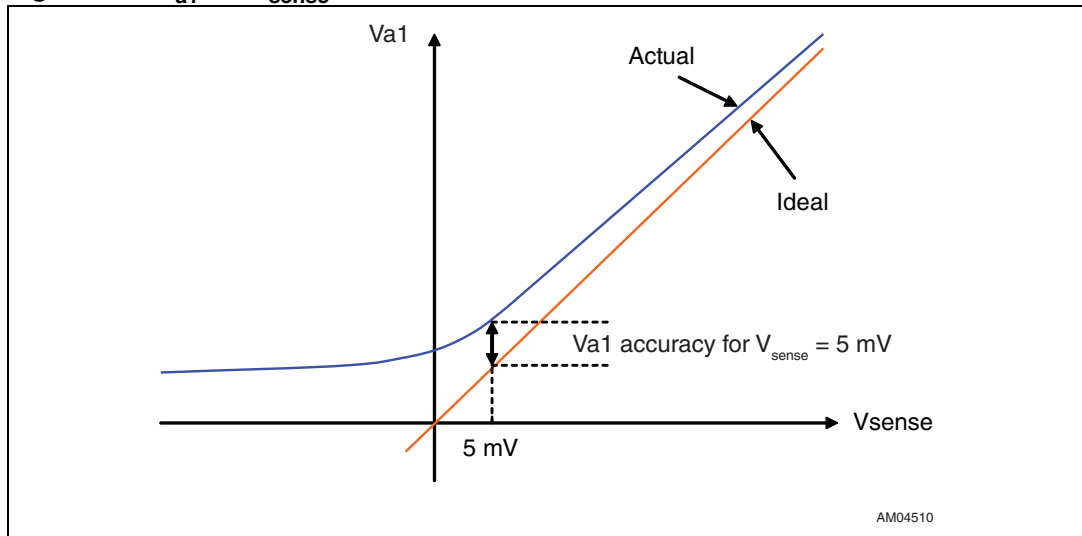

The output voltage accuracy, expressed as a percentage, can be calculated with the following formula:

$$\Delta V_{a1} = \frac{\text{abs}(V_{a1} - (A_v \cdot V_{\text{sense}}))}{A_v \cdot V_{\text{sense}}}$$

with $A_v = 20 \text{ V/V}$.

7 Application information

The TSC102 can be used to measure current and feed back the information to a microcontroller, as shown in [Figure 21](#).

Figure 21. Typical application schematic

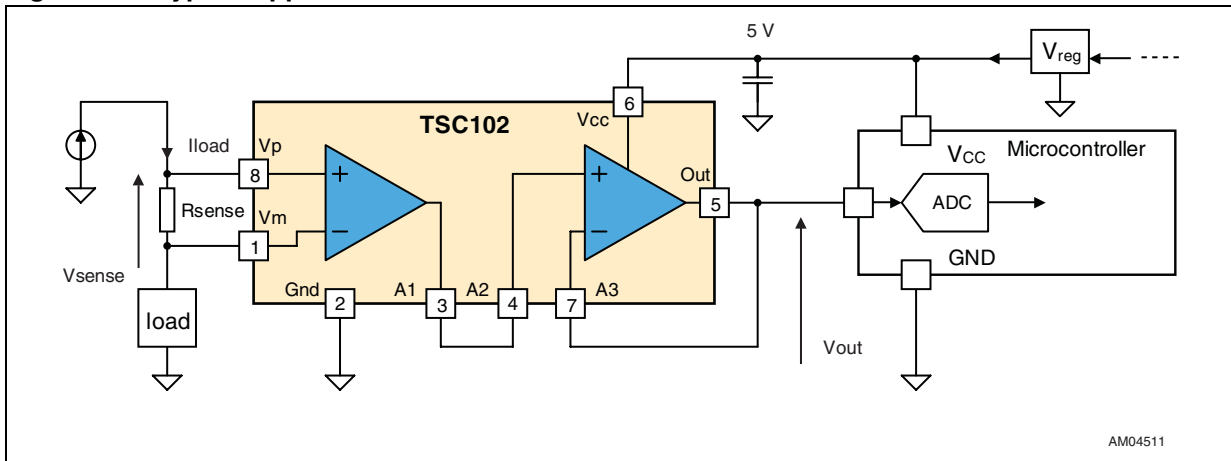

This fully-accessible output amplifier offers wide schematic possibilities, as shown in the following examples.

Figure 22. Gain higher than 20

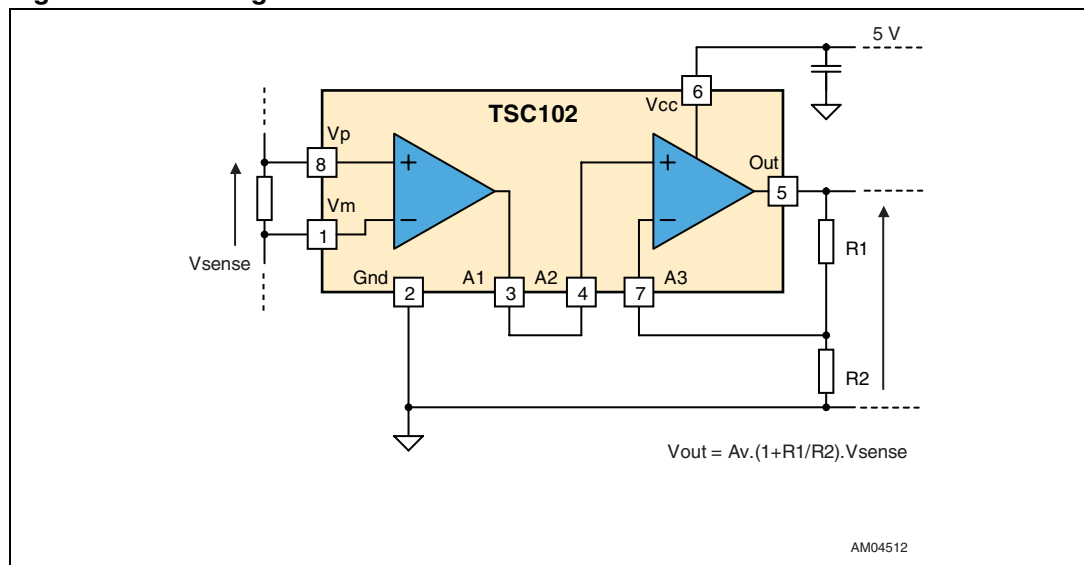

Figure 23. Gain lower than 20

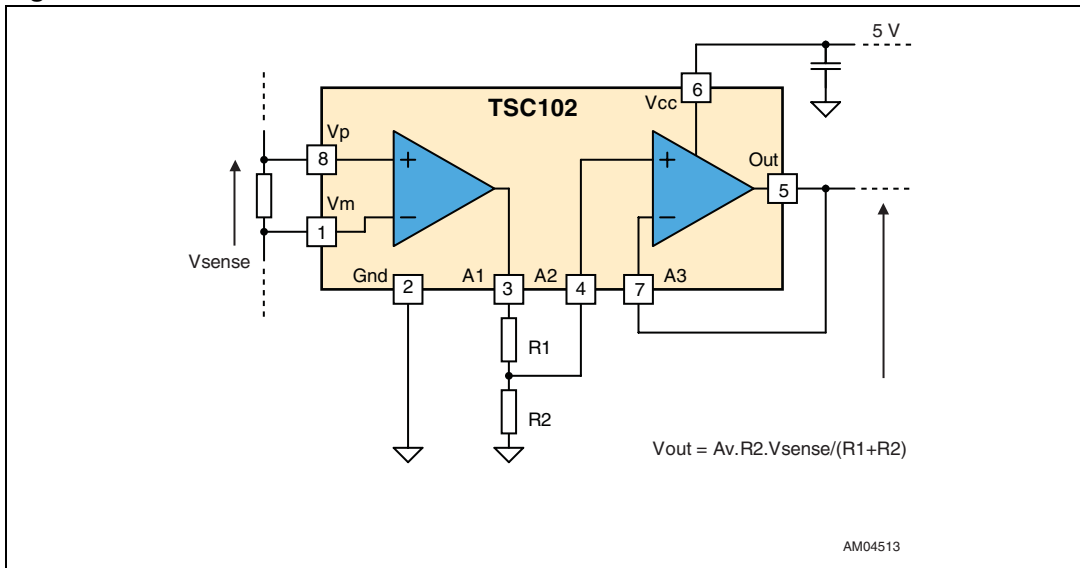

Figure 24. Overcurrent protection

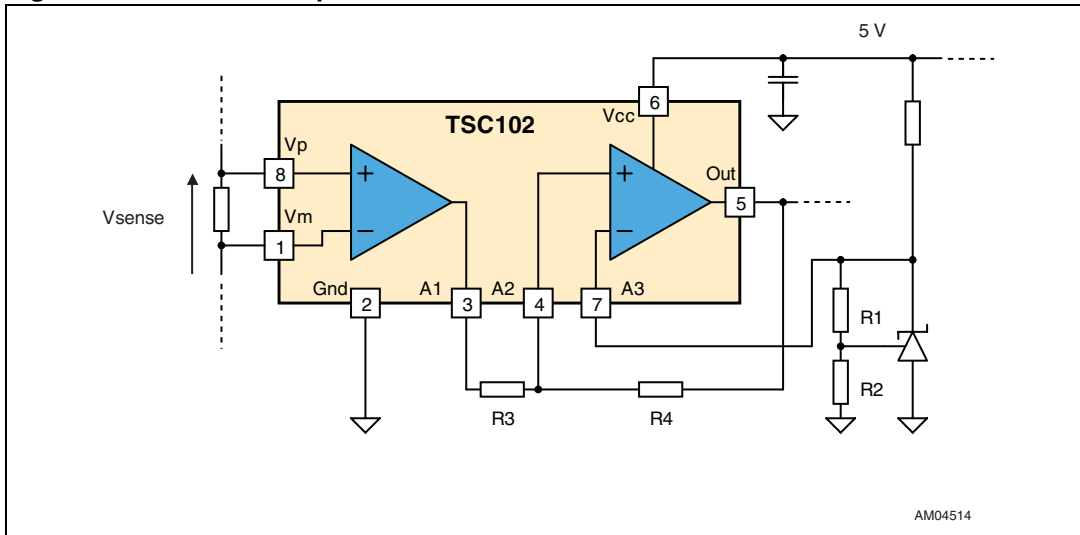
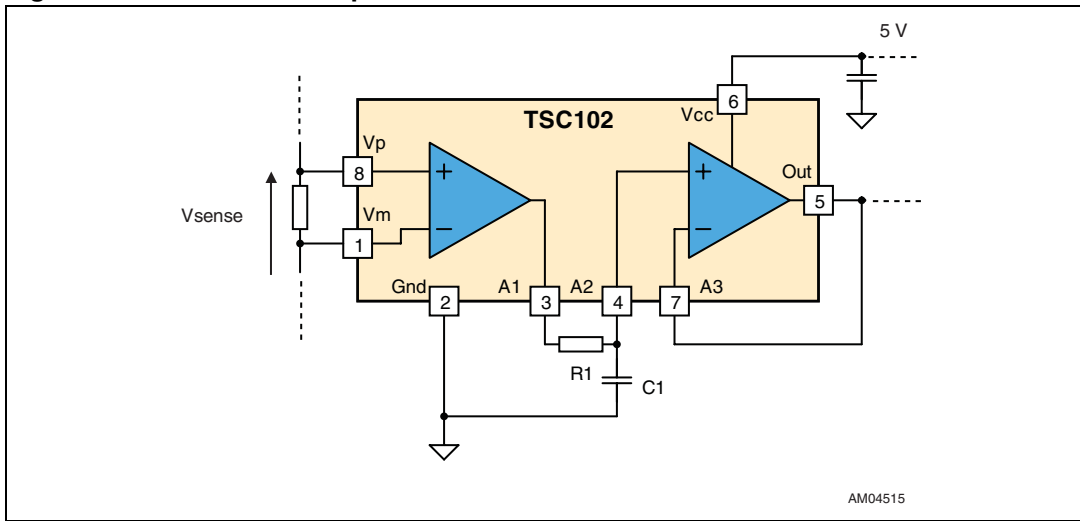
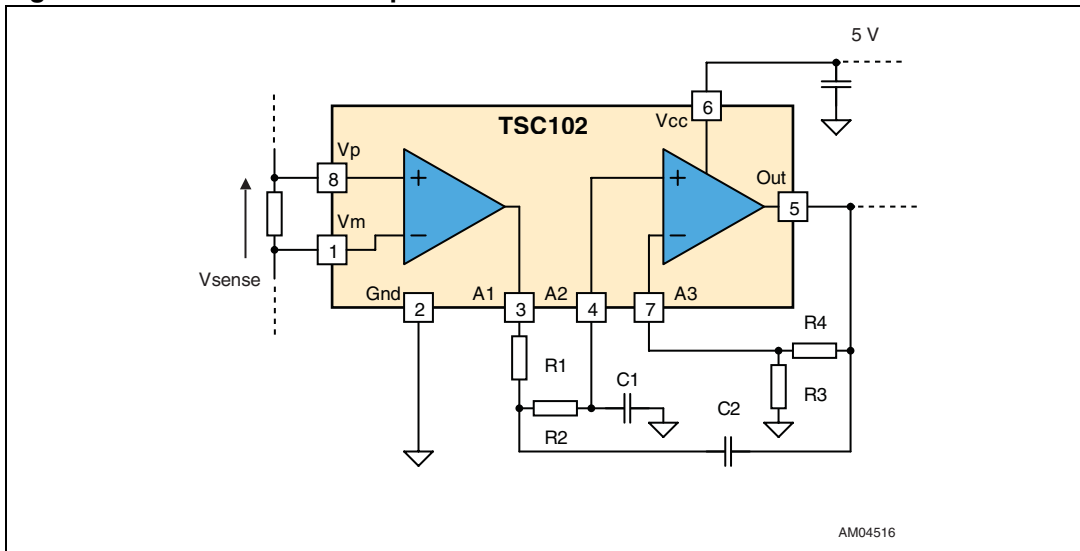

Figure 25. First-order low-pass filter



AM04515

Figure 26. Second-order low-pass filter



AM04516

8 Package information

In order to meet environmental requirements, ST offers these devices in different grades of ECOPACK[®] packages, depending on their level of environmental compliance. ECOPACK[®] specifications, grade definitions and product status are available at: www.st.com. ECOPACK[®] is an ST trademark.

8.1 SO-8 package information

Figure 27. SO-8 package mechanical drawing

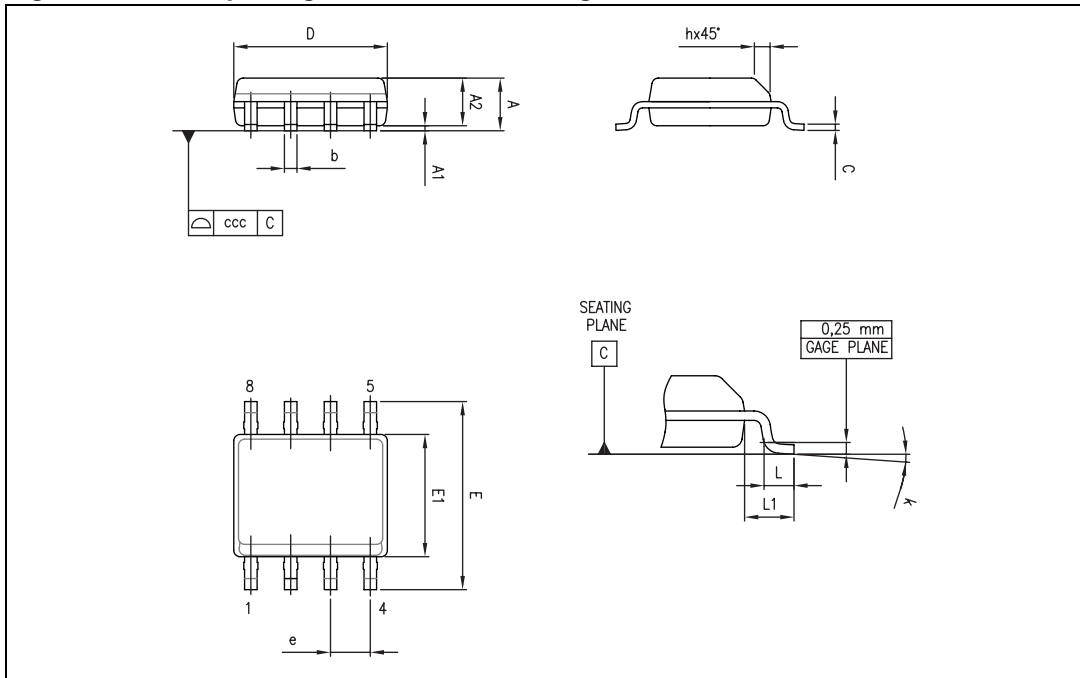

Table 10. SO-8 package mechanical data

Ref.	Dimensions					
	Millimeters			Inches		
	Min.	Typ.	Max.	Min.	Typ.	Max.
A			1.75			0.069
A1	0.10		0.25	0.004		0.010
A2	1.25			0.049		
b	0.28		0.48	0.011		0.019
c	0.17		0.23	0.007		0.010
D	4.80	4.90	5.00	0.189	0.193	0.197
E	5.80	6.00	6.20	0.228	0.236	0.244
E1	3.80	3.90	4.00	0.150	0.154	0.157
e		1.27			0.050	
h	0.25		0.50	0.010		0.020
L	0.40		1.27	0.016		0.050
L1		1.04			0.040	
k	0		8°	1°		8°
ccc			0.10			0.004

8.2 TSSOP-8 package information

Figure 28. TSSOP8 package mechanical drawing

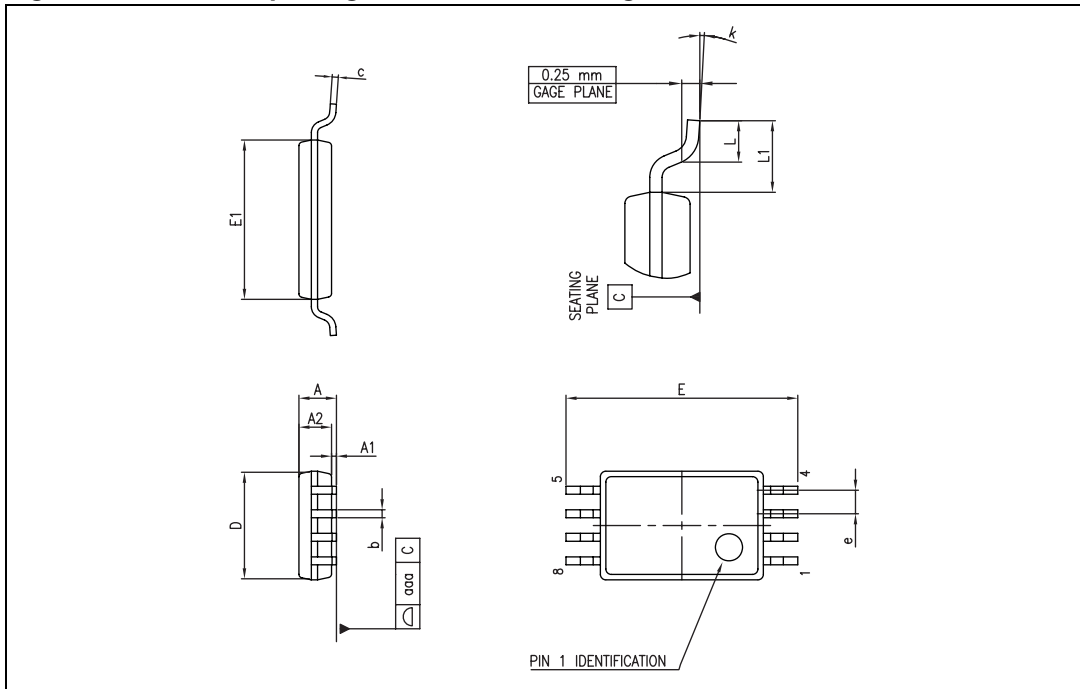

Table 11. TSSOP8 package mechanical data

Ref.	Dimensions					
	Millimeters			Inches		
	Min.	Typ.	Max.	Min.	Typ.	Max.
A			1.20			0.047
A1	0.05		0.15	0.002		0.006
A2	0.80	1.00	1.05	0.031	0.039	0.041
b	0.19		0.30	0.007		0.012
c	0.09		0.20	0.004		0.008
D	2.90	3.00	3.10	0.114	0.118	0.122
E	6.20	6.40	6.60	0.244	0.252	0.260
E1	4.30	4.40	4.50	0.169	0.173	0.177
e		0.65			0.0256	
k	0°		8°	0°		8°
L	0.45	0.60	0.75	0.018	0.024	0.030
L1		1			0.039	
aaa			0.10			0.004

9 Ordering information

Table 12. Order codes

Part number	Temperature range	Package	Packing	Marking
TSC102IPT	-40° C, +125° C	TSSOP8	Tape & reel	102I
TSC102IDT		SO-8	Tape & reel	TSC102I
TSC102IYPT	-40° C, +125° C Automotive grade	TSSOP8 ⁽¹⁾	Tape & reel	102Y
TSC102IYDT		SO-8 ⁽²⁾	Tape & reel	TSC102IY

1. Qualification and characterization according to AEC Q100 and Q003 or equivalent, advanced screening according to AEC Q001 & Q 002 or equivalent are on-going.
2. Qualification and characterization according to AEC Q100 and Q003 or equivalent, advanced screening according to AEC Q001 & Q 002 or equivalent.

10 Revision history

Table 13. Document revision history

Date	Revision	Changes
09-Nov-2009	1	Initial release.
03-Mar-2011	2	Added automotive grade qualification for SO-8 package (note 2 under Table 12).

Please Read Carefully:

Information in this document is provided solely in connection with ST products. STMicroelectronics NV and its subsidiaries ("ST") reserve the right to make changes, corrections, modifications or improvements, to this document, and the products and services described herein at any time, without notice.

All ST products are sold pursuant to ST's terms and conditions of sale.

Purchasers are solely responsible for the choice, selection and use of the ST products and services described herein, and ST assumes no liability whatsoever relating to the choice, selection or use of the ST products and services described herein.

No license, express or implied, by estoppel or otherwise, to any intellectual property rights is granted under this document. If any part of this document refers to any third party products or services it shall not be deemed a license grant by ST for the use of such third party products or services, or any intellectual property contained therein or considered as a warranty covering the use in any manner whatsoever of such third party products or services or any intellectual property contained therein.

UNLESS OTHERWISE SET FORTH IN ST'S TERMS AND CONDITIONS OF SALE ST DISCLAIMS ANY EXPRESS OR IMPLIED WARRANTY WITH RESPECT TO THE USE AND/OR SALE OF ST PRODUCTS INCLUDING WITHOUT LIMITATION IMPLIED WARRANTIES OF MERCHANTABILITY, FITNESS FOR A PARTICULAR PURPOSE (AND THEIR EQUIVALENTS UNDER THE LAWS OF ANY JURISDICTION), OR INFRINGEMENT OF ANY PATENT, COPYRIGHT OR OTHER INTELLECTUAL PROPERTY RIGHT.

UNLESS EXPRESSLY APPROVED IN WRITING BY AN AUTHORIZED ST REPRESENTATIVE, ST PRODUCTS ARE NOT RECOMMENDED, AUTHORIZED OR WARRANTED FOR USE IN MILITARY, AIR CRAFT, SPACE, LIFE SAVING, OR LIFE SUSTAINING APPLICATIONS, NOR IN PRODUCTS OR SYSTEMS WHERE FAILURE OR MALFUNCTION MAY RESULT IN PERSONAL INJURY, DEATH, OR SEVERE PROPERTY OR ENVIRONMENTAL DAMAGE. ST PRODUCTS WHICH ARE NOT SPECIFIED AS "AUTOMOTIVE GRADE" MAY ONLY BE USED IN AUTOMOTIVE APPLICATIONS AT USER'S OWN RISK.

Resale of ST products with provisions different from the statements and/or technical features set forth in this document shall immediately void any warranty granted by ST for the ST product or service described herein and shall not create or extend in any manner whatsoever, any liability of ST.

ST and the ST logo are trademarks or registered trademarks of ST in various countries.

Information in this document supersedes and replaces all information previously supplied.

The ST logo is a registered trademark of STMicroelectronics. All other names are the property of their respective owners.

© 2011 STMicroelectronics - All rights reserved

STMicroelectronics group of companies

Australia - Belgium - Brazil - Canada - China - Czech Republic - Finland - France - Germany - Hong Kong - India - Israel - Italy - Japan - Malaysia - Malta - Morocco - Philippines - Singapore - Spain - Sweden - Switzerland - United Kingdom - United States of America

www.st.com