

G5M1119

0.5A Positive Low Dropout Fixed-Mode Regulator with EN Function

Description

The G5M1119 is a low dropout positive fixed-mode regulator with minimum of 0.5A output current capability. The product is specifically designed to provide well-regulated supply for low voltage IC applications such as high-speed bus termination and low current 3.3V logic supply. G5M1119 is also well suited for other applications such as VGA cards. G5M1119 is guaranteed to have <1.3V dropout at full load current making it ideal to provide well regulated fixed outputs of 1.5V to 12V with up to 18V input supply. The G5M1119 offers a TTL-Logic compatible enable pin.

Features

- 1.3V maximum dropout full load current
- Fast transient response
- Output current limiting
- Built-in thermal shutdown
- Good noise rejection
- 5-Terminal device with Fixed 1.5V, 1.8V, 2.5V, 3.3V, 5.0V, 9.0V, 12V, output

Applications

- PC peripheral
- Communication
- CDROM

Package Dimensions

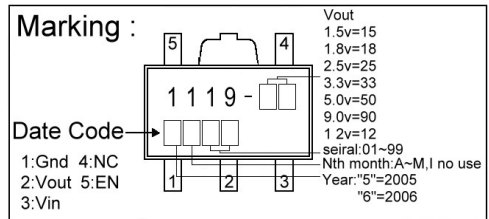
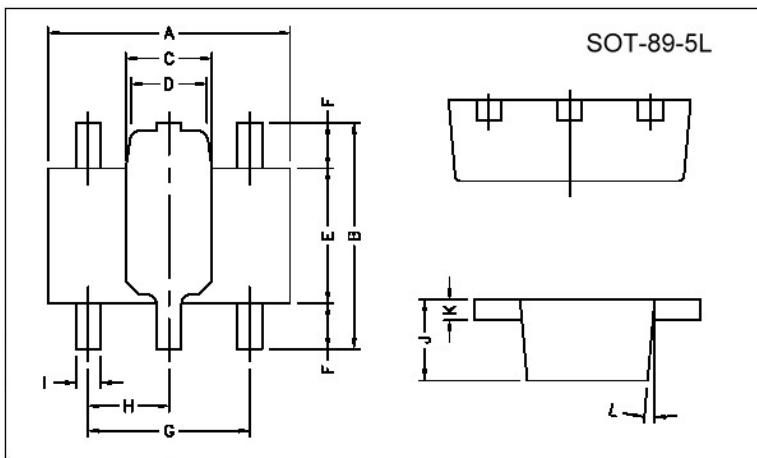

REF.	Millimeter		REF.	Dimensions	
	Min.	Max.		Millimeter	
A	4.40	4.60	G	3.00 REF.	
B	4.05	4.25	H	1.50 REF.	
C	1.50	1.70	I	0.40	0.52
D	1.30	1.50	J	1.40	1.60
E	2.40	2.60	K	0.35	0.41
F	0.80	-	L	5° TYP.	

Typical Circuit

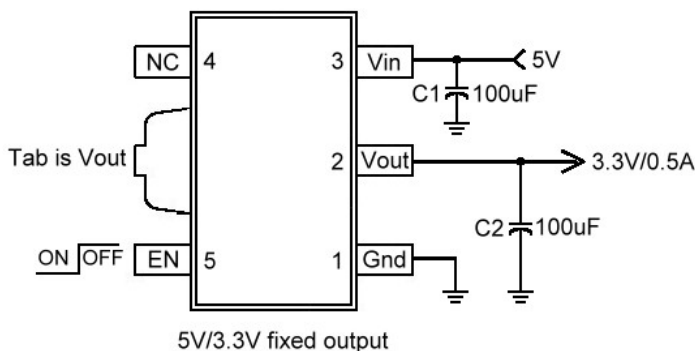

Pin Descriptions

Name	Pin#	Function
GND	1	Ground
Vout	2	The output of the regulator. A minimum of 10 μ F capacitor must be connected from this pin to ground to insure stability.
Vin	3	The input pin of regulator. Typically a large storage capacitor is connected from this pin to ground to insure that the input voltage does not sag below the minimum dropout voltage during the load transient response .This pin must always be 1.3V higher than Vout in order for the device to regulate properly.
EN	5	The input pin of regulator. TTL/COMS compatible input Logic high=disable output, Logic Low or open= Enable output. (internal Pull-down resistor~100k).

Absolute Maximum Ratings

Symbol	Parameter	Ratings	Unit
VIN	DC Supply Voltage	-0.3 to 18	V
PD	Power Dissipation	Internally Limited	
TST	Storage Temperature	-65 ~ + 150	$^{\circ}$ C
TOP	Operating Junction Temperature Range	0 ~ + 150	$^{\circ}$ C

Electrical Characteristics

Parameter	Conditions		Min	Typ	Max	Unit
Output Voltage	G5M1119-1.5	I _o =10mA, T _J =25 $^{\circ}$ C, 3V \leq V _{IN} \leq 12V	1.470	1.500	1.530	V
	G5M1119-1.8	I _o =10mA, T _J =25 $^{\circ}$ C, 3.3V \leq V _{IN} \leq 12V	1.764	1.800	1.836	V
	G5M1119-2.5	I _o =10mA, T _J =25 $^{\circ}$ C, 4V \leq V _{IN} \leq 12V	2.450	2.500	2.550	V
	G5M1119-3.3	I _o =10mA, T _J =25 $^{\circ}$ C, 4.8V \leq V _{IN} \leq 12V	3.235	3.300	3.365	V
	G5M1119-5.0	I _o =10mA, T _J =25 $^{\circ}$ C, 6.5V \leq V _{IN} \leq 12V	4.900	5.000	5.100	V
	G5M1119-9.0	I _o =10mA, T _J =25 $^{\circ}$ C, 10.5V \leq V _{IN} \leq 18V	8.820	9.000	9.180	V
	G5M1119-12.0	I _o =10mA, T _J =25 $^{\circ}$ C, 13.5V \leq V _{IN} \leq 18V	11.76	12.00	12.24	V
Line Regulation	G5M1119-XXX	I _o =10mA, V _{OUT} +1.5V < V _{IN} <15V, T _J =25 $^{\circ}$ C	-	-	0.2	%
Load Regulation	G5M1119-1.5	V _{IN} =3.0V, 0mA < I _o <0.5A, T _J =25 $^{\circ}$ C (Note 1,2)	-	12	15	mV
	G5M1119-1.8	V _{IN} =3.3V, 0mA < I _o <0.5A, T _J =25 $^{\circ}$ C (Note 1,2)	-	15	18	mV
	G5M1119-2.5	V _{IN} =4.0V, 0mA < I _o <0.5A, T _J =25 $^{\circ}$ C (Note 1,2)	-	20	25	mV
	G5M1119-3.3	V _{IN} =5.0V, 0mA < I _o <0.5A, T _J =25 $^{\circ}$ C (Note 1,2)	-	26	33	mV
	G5M1119-5.0	V _{IN} =8.0V, 0mA < I _o <0.5A, T _J =25 $^{\circ}$ C (Note 1,2)	-	40	50	mV
	G5M1119-9.0	V _{IN} =12V, 0mA < I _o <0.5A, T _J =25 $^{\circ}$ C (Note 1,2)	-	70	90	mV
	G5M1119-12.0	V _{IN} =15V, 0mA < I _o <0.5A, T _J =25 $^{\circ}$ C (Note 1,2)	-	100	120	mV
Dropout Voltage (V _{IN} -V _{OUT})	G5M1119-XXX	I _o =0.5A, (Δ V _{OUT} =0.1% V _{OUT})	-	1.1	1.3	V
Current Limit	G5M1119-XXX	V _{IN} -V _{OUT} =5V	0.6	-	-	A
Minimum Load Current	G5M1119-XXX	0 $^{\circ}$ C \leq T _J \leq 125 $^{\circ}$ C	-	-	10	mA
Enable Input Voltage	G5M1119-XXX	Logic Low (ON)	-	-	0.8	V
		Logic High (OFF)	2.0	-	-	
Enable Input Current	G5M1119-XXX	V _{EN} =0.8	-	-	10	μ A
		V _{EN} =2.0	-	-	30	
Thermal Regulation	T _A =25 $^{\circ}$ C, 30ms pulse		-	0.008	0.04	%/W
Ripple Rejection	F=120HZ, C _{OUT} =25 μ F Tantalum, I _{OUT} =0.5A		-	60	70	dB
	G5M1119-XXX	V _{IN} =V _{OUT} +3V				dB
Temperature Stability	I _o =10mA		-	0.5	-	%

θ_{JA} Thermal Resistance Junction-to-Ambient(No heat sink ;No air flow)		-	300	-	°C/w
θ_{JC} Thermal Resistance Junction-to-Case	Control Circuitry/Power Transistor	-	100	-	°C/w

Note 1: See thermal regulation specifications for changes in output voltage due to heating effects. Line and load regulation are measured at a constant junction temperature by low duty cycle pulse testing. Load regulation is measured at the output lead =1/18" from the package.

Note 2: Line and load regulation are guaranteed up to the maximum power dissipation of 5W. Power dissipation is determined by the input/output difference and the output current. Guaranteed maximum power dissipation will not be available over the full input/output range.

Note 3: Quiescent current is defined as the minimum output current required in maintaining regulation. At 12V input/output differential the device is guaranteed to regulate if the output current is greater than 10mA.

Characteristics Curve

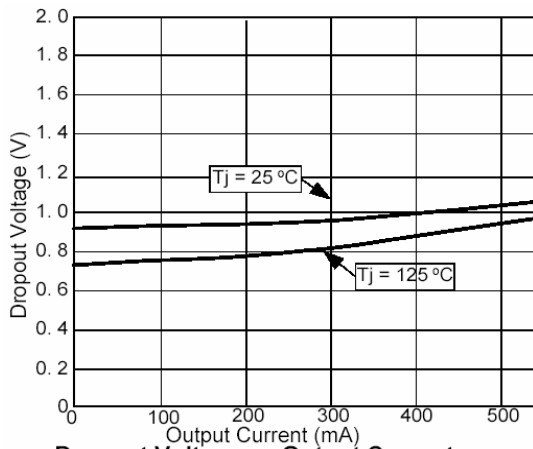

Dropout Voltage vs Output Current

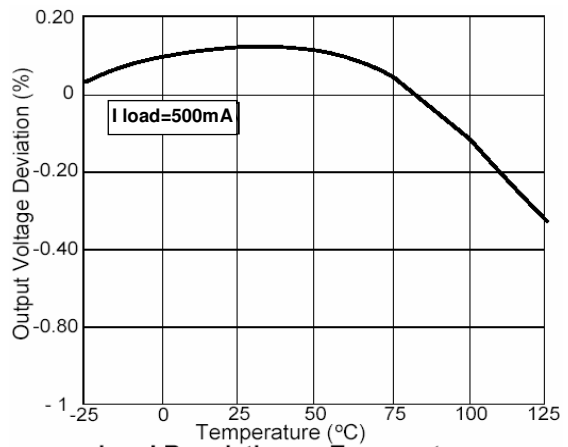

Load Regulation vs Temperature

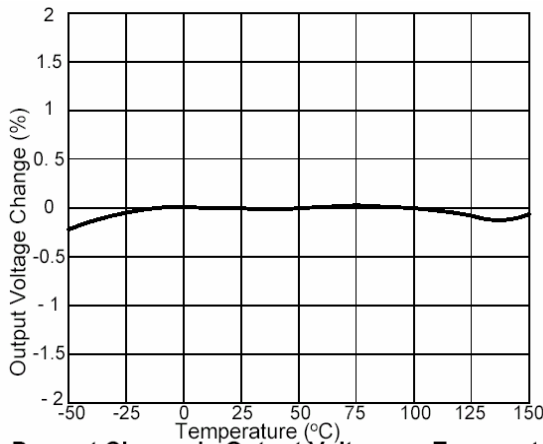

Percent Change in Output Voltage vs Temperature

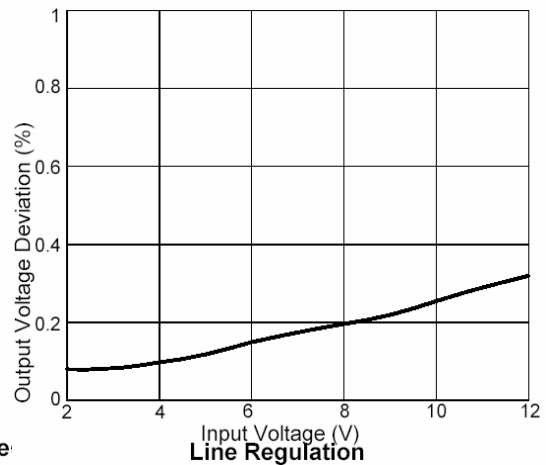

Line Regulation

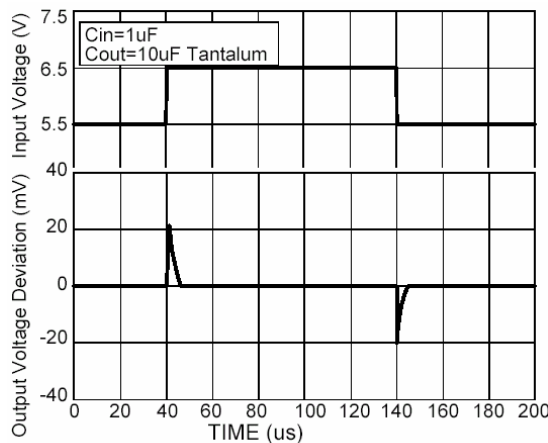

Line Transient Response

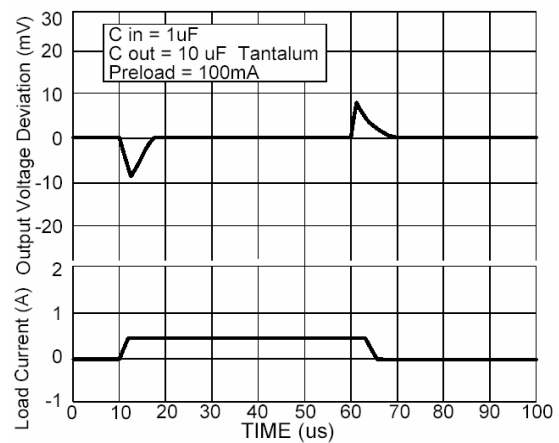

Load Transient Response

Important Notice:

- All rights are reserved. Reproduction in whole or in part is prohibited without the prior written approval of GTM.
- GTM reserves the right to make changes to its products without notice.
- GTM semiconductor products are not warranted to be suitable for use in life-support Applications, or systems.
- GTM assumes no liability for any consequence of customer product design, infringement of patents, or application assistance.

Head Office And Factory:

- **Taiwan:** No. 17-1 Tatung Rd. Fu Kou Hsin-Chu Industrial Park, Hsin-Chu, Taiwan, R. O. C.
- TEL : 886-3-597-7061 FAX : 886-3-597-9220, 597-0785
- **China:** (201203) No.255, Jang-Jiang Tsai-Lueng RD. , Pu-Dung-Hsin District, Shang-Hai City, China
- TEL : 86-21-5895-7671 ~ 4 FAX : 86-21-38950165